

Model 363 Control Valve

Operation, Parts, and Instruction Manual



Figure 1 363 Control Valve



TABLE OF CONTENTS

Introduction	2	Lapping	9
General	2	Assembly	9
Scope	2	Seat Ring & Gasket Assembly	9
Specifications	3	Regular / Extension Plug & Stem Assembly	10
Unpacking Valve	4	Plug / Stem / Seat Ring Retainer	10
Installation	4	Bellows Style Bonnet Trim Assembly	10
Valve Installation & Packing Inspection	4	Bonnet Assembly	11
Air Piping	4	Packing Assembly	11
Periodic Inspection	4	Body to Bonnet Stud Torque - Table 1	13
Maintenance	5	Packing Nut Torque - Table 2	13
Removing Actuator from Valve	5	Valve Stem Connection Torque - Table 3	14
Packing Maintenance	6	Packing Diagrams - Figures 8 & 9	14 & 15
Valve Disassembly	6	Valve Cross Section - Figure 10	16
Bonnet Removal	6	Bellows Bonnet Assembly - Figures 11 & 12	17
Trim Parts Removal	7	Extension Bonnet Diagram - Figure 13	18
Plug / Stem Disassembly	7	Valve Pug Diagrams - Figure 14	18
Bellows Stem / Plug & Seat Ring Removal	7	Parts	19
Seat Ring & Gasket Removal	8	Model Builder	24
Packing & Packing Parts Removal	8		
Parts Inspection	8		



Model 363 Control Valve

Operation, Parts, and Instruction Manual

NOTICE

These instructions are meant to be used with the Dyna-Flo 363 Technical Bulletin as they refer to Figures and Tables therein. If you do not have the Technical Bulletin, contact Dyna-Flo immediately, or visit www.dynaflo.com

Each control valve is factory checked. Check the calibration for the specific application, before a valve is put into service.

It is the intention of this document to provide users with an accurate guide for safe installation and maintenance of the 363 Control Valve. Revisions and updates are available at above mentioned website.

INTRODUCTION

The Model 363 control valve is part of the Model 360 Series of control Valves.

The Model 363 is a top guided, unbalanced, single port valve that is suitable for either throttling or on off control of either liquids or gases. Metal to metal seating is standard on Model 363 valves.

The standard actuator for the Model 363 valve is a Dyna-Flo model DFC or DFO linear actuator. These heavy-duty actuators are spring return diaphragm style, and can be used for throttling or on-off service, with or without a valve positioner.

The Model 363 control valves are manufactured to a high level of quality specifications to ensure superior performance and customer satisfaction.

GENERAL

The following instructions are to be thoroughly reviewed and understood prior to installing, operating or performing maintenance on this equipment. Work on this equipment should be performed by experienced personnel. Throughout the manual, safety and caution notes appear and must be strictly followed, to prevent serious injury or equipment malfunction.

SCOPE

The control valve configuration and construction materials were selected to meet particular pressure, temperature, and process conditions. Some material combinations are limited in their pressure and temperature ranges. Do not apply any other conditions to the valve without first contacting your Dyna-Flo sales office.

This manual is written to be a practical and useful guide maintaining the Dyna-Flo 363 Control Valve.

CAUTION

To avoid personal injury or installation damage as a result of the sudden release of process pressure or the breaking of parts, do not install the valve assembly where service conditions could exceed the limits stated in this manual or on the equipment nameplates. Use government codes, accepted industry standards and good piping practices to select pressure-relieving equipment for protection of your installation. It is also important to wear the proper protective equipment when performing any installation or maintenance activity.

Model 363 Control Valve

Operation, Parts, and Instruction Manual



SPECIFICATIONS

Configurations

The Model 363 control valve is a high capacity single port, globe style valve with a bolted type bonnet. The standard valve plug action is push down to close. Refer to Table 1 of the Sales Bulletin.

Consult your Dyna-Flo sales office for other available configurations.

Sizes and Connection Styles (Refer to Table 1 of the Sales Bulletin)

Model:	363
Size:	1/2", 3/4", 1", 1-1/2", 2"
Body:	Globe (All Sizes)
Rating:	ASME 150 / 300 / 600
Connection:	RF / RTJ / BWE / SWE / NPT - All Sizes

Maximum Inlet Pressures and Temperatures

Flanged valves consistent with ASME Class 150, 300, and 600 rating as per ASME B16.34, unless limited.

Maximum Pressure Drops

Maximum pressure drop is the same as maximum inlet pressure unless restricted by the following:

Material Temperature Limits: Tables 15, 16, 18, 19, 21, 22 of the Sales Bulletin.

Characteristic and Flow Direction

- Equal Percentage (Standard) - Flow Up
- Quick Opening - Flow Up
- Linear - Flow Up
- Dyna-Form (Equal Percentage) - Flow Up
- Dyna-Flute 1 (Equal Percentage) - Flow Up
- Dyna-Flute 3 (Equal Percentage) - Flow Up
- Dyna-Flat (Equal Percentage) - Flow Up

Dimensions

Valve and Actuator Outline Dimension Diagram

Refer to Figure 2 of the Sales Bulletin.

Valve and Actuator Assembly Dimensions

Refer to Tables 5 to 13 of the Sales Bulletin.

Approximate Valve Body and Actuator Weights

Refer to Table 3 of the Sales Bulletin.

Materials

Body and bonnet material options include:

LCC (A350-LF2 optional* bonnet material)

WCC (A350-LF2 optional* bonnet material)

WC9 (A182-F22 optional* bonnet material)

CF8M (A182-F316 optional* bonnet material)

***NOTE:** Dyna-Flo reserves the right to substitute a cast material with the forged bar equivalent in the event a casting is not available.

Refer to Figure 14 of the Sales Bulletin for valve construction material temperature limitations. Refer to Table 19 of the Sales Bulletin for trim selections.

Cross-Section of the Model 363 Control Valves

Refer to Figure 10.

Port Diameters and Maximum Valve Plug Travel

Refer to Tables 4 to 5 of the Sales Bulletin.

Packing Type and Examples

The Standard packing is PTFE V-ring. Live-loaded low emission, graphite, KALREZ® and other packing arrangements are available. Refer to Figures 8 & 9.

Maximum Valve Sizing Coefficients

For standard coefficients at maximum travel, refer to Tables 27 & 28 of the Sales Bulletin. For full list of coefficients refer to document P-CVSM.

For more information and other options contact your Dyna-Flo sales office.



Model 363 Control Valve

Operation, Parts, and Instruction Manual

UNPACKING VALVE FROM SHIPPING CONTAINER

Check the packing list, verify that the list includes all the materials in the shipping container before unpacking. Valve information can be found on the nameplate (Key 38). Refer to Figure 3 for nameplate location.

When lifting the valve from shipping container, place properly rated lifting straps securely around the neck of the actuator, refer to Figure 3 for strap placement. Straps should be placed to avoid damage to tubing and other mounted accessories.

For valve assemblies without an attached actuator, use caution when lifting or positioning straps so as not to damage the valve stem.

Lift the valve/actuator assembly using proper lifting techniques.

WARNING

The following maintenance procedures require removing the control valve from service. To avoid personnel injury, only qualified technicians should perform the following procedures. Always ensure the control valve is fully released of pressure or process fluid before starting maintenance.

INSTALLATION

Before installing the valve, clean dirt, welding chips, scale or other foreign material from the line. Inspect flange gasket surfaces for damage. Check packing box bolting for proper tightness. Packing nuts should be slightly over finger-tight; however, tighten only as necessary to prevent stem leakage.

- 1 Install the valve with flow through the valve in the direction shown by the flow arrow on the valve body. Model 363 valves normally flow up. The valve assembly may be installed in any position unless limited by vibration considerations.

CAUTION

The normal method is with the actuator vertical above the valve body. In some non-vertical applications, the actuator may need to be supported.

WARNING

Keep hands, hair and clothing away from all moving parts when operating the valve! Serious injury can result from failure to do so!

- 2 When possible, stroke the valve and check for smooth operation through the full-stroke. Unsteady valve stem movement could be an indication of an internal problem.

Valve Installation and Packing Inspection:

CAUTION

Do not over tighten packing! This can cause excessive packing wear and high stem friction that may impede stem movement! Refer to Table 2 For Packing Torque.

- 1 Standard Single PTFE Packing (Figure 8) should be tightened until the edge of the packing follower (Key 10) makes contact with the top of the bonnet (Key 1).
- 2 For Double PTFE Packing and High Temperature Graphite Packing, refer to Packing Torque Charts on Page 14 for correct packing torque value and make sure packing is tightened appropriately.
- 3 For Live Loaded Packing initial re-tightening of packing should not be required, review Packing Maintenance for Live Loaded Packing for in-depth instruction.

Air Piping

The actuators are designed to accept 1/4" NPT connection. Use 3/8" OD tubing (or equivalent) for all air lines. All connections must be free of leaks.

CAUTION

Do not exceed maximum casing pressure indicated on serial plate located on the yoke of the actuator.

PERIODIC INSPECTION

CAUTION

Use safe work practices and lock out procedures when isolating valves and actuators! Always be aware of flammable instrument gas!

- 1 Avoid personal injury from sudden release of process pressure! Before performing any maintenance operation:
 - A Disconnect any power supply media lines providing air / gas pressure, electric power, or a control signal to the actuator. Ensure the actuator cannot suddenly operate the valve.
 - B Isolate the valve from process pressure with bypass valves or completely shut off the process. Relieve process pressure, and drain the process fluid from the up and down stream of the valve.
 - C Vent the pneumatic actuator loading pressure and relieve any actuator spring preload.

Model 363 Control Valve

Operation, Parts, and Instruction Manual



- D Use Safety lock-out procedures to be sure that the above provisions stay in effect while you complete the work on your equipment.
- 2 Check for process fluid leakage to the atmosphere through the body to bonnet joint and (if equipped) any NPT connection.
- 3 Examine the valve for damage caused by corrosive fumes or process drippings.
- 4 Clean the valve and repaint areas of severe oxidation.
- 5 Make sure positioner linkage (if equipped) and stem connector are securely fastened. If the stem connector is loose, check plug thread engagement and retighten. Refer to the Dyna-Flo Model DFC or DFO Manual for detailed instructions.
- 6 Ensure all accessories, mounting brackets and fasteners are secure.
- 7 Clean any dirt and foreign material from the valve stem.

MAINTENANCE

Only "Certified Technicians" should be disassembled and inspecting these valves and actuators.

CAUTION

Actuator spring is under compression. The actuator is also under pneumatic / gas pressure. Ensure actuator has been disconnected from supply lines before starting any work on the actuator. The actuator needs to be supported before the yoke nut can be removed, failure to support actuator could result in actuator damage and / or personal injury.

Removing Actuator from Valve

Refer to the Dyna-Flo Model DFC/DFO Manual for detailed instructions.

- 1 Disconnect all pneumatic/gas supply lines and any other lines that might supply pressure to the actuator.
ON MODEL DFC (FAIL CLOSED) ACTUATORS: Connect a 30 psi supply line to the inlet port of the actuator. Be sure not to exceed the maximum casing pressure. This will open the valve and take downward force off the stem connector.

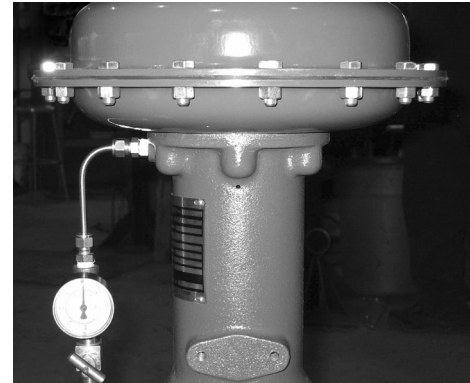

Figure 2 Needle Valve with Gauge Setup

- 2 Remove the stem connector (Refer to the DFC / DFO Instruction Manual for stem connector removal instructions).
- 3 Support the actuator - the actuator may be able to be removed manually on the smaller sizes. When lifting the valve from shipping container, place properly rated fitting straps securely around the neck of the actuator, refer to Figure 3 for strap placement. Straps should be placed to avoid damage to tubing and other mounted accessories.
- 4 Use a blunted heavy chisel to loosen yoke nut (See Figure 4), unscrew yoke nut off of bonnet. Lift actuator off of valve and store in a safe place.

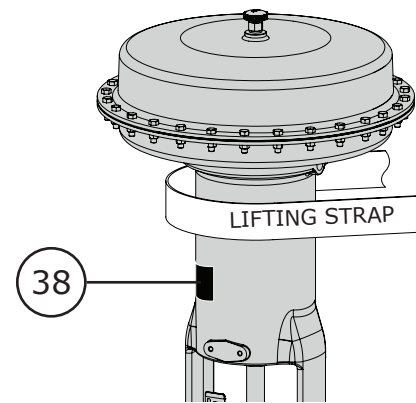

Figure 3 Actuator Lifting Hooks



Model 363 Control Valve

Operation, Parts, and Instruction Manual

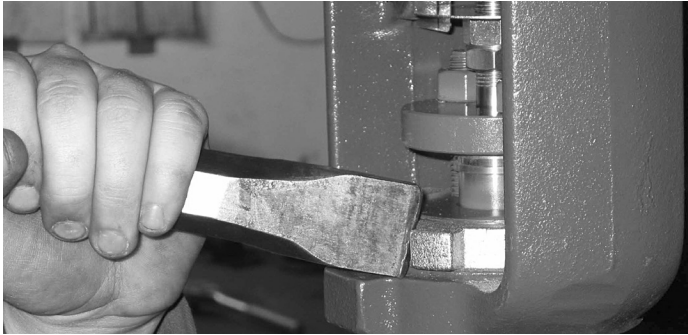

Figure 4 Yoke nut being loosened with a chisel

MAINTENANCE (Continued)

Removing Actuator from Valve (Continued)

- 5 Remove the jam nuts and travel indicator from the valve stem. Refer to DFC / DFO actuator manual for disassembly procedures for actuators.
- 6 Once actuator has been removed from the valve the air pressure in the actuator can be released. (DFC actuator only)

Packing Maintenance

Refer to Figures 8 & 9 for packing orientation and Key numbers for the following section.

For single (spring-loaded) packing:

- A** Spring-loaded packing has constant force applied to the packing set (Key 2) through a spring (Key 5) in the packing bore. Ensure that the packing follower (Key 10) is in contact with the bonnet (Key 1), if not tighten the packing nuts (Key 14) until the packing follower comes in contact with the bonnet. If this does not stop the leak then the packing will need to be replaced. In some cases the bonnet and/or stem (Key 20) may need to be polished or replaced.
- B** Refer to **Valve Disassembly** section for Packing Removal and Inspection.

CAUTION

Do not tighten the packing nuts past the recommended maximum torque value as this will cause high stem friction and could cause the valve to operate incorrectly.

For double packing / graphite ring packing:

- A** Double packing consists of two packing sets (Key 2) separated by a lantern ring (Key 6). Both styles of packing require that the packing nuts (Key 14) be kept tight to keep force on the packing. If leakage is detected from the packing, the packing nuts can be tightened to apply more force on the packing set (make sure not to exceed the maximum allowable torque values, see Table 2). If this does not seal off the leak then the packing will need to be replaced. In some cases the bonnet (Key 1) and/or stem (Key 20) may need to be polished or replaced.
- B** Refer to Valve Disassembly section for Packing Removal and Inspection. Refer to Figures 8 and 9 for double and graphite packing arrangements.

VALVE DISASSEMBLY

CAUTION

If maintenance is to be performed on the valve in-line, relieve process pressure and drain the process media from the upstream and downstream sides of the valve. Check that bypass valves are used or the process has been completely shut down.

Bonnet Removal

- 1 Remove the packing nuts (Key 14) and loosen the bonnet nuts (Key 35) a few millimeters. The bonnet may need to be rocked loose or loosened from the body by prying at the bonnet-to-body joint (See Figure 5). Take care not to damage the gasket-sealing surface when separating the bonnet. If no process medium leaks from the bonnet-to-body joint removal of the bonnet nuts (Key 35) can proceed.
- 2 A razor or a pick-set can be used to remove old gaskets (Keys 29, 31, 32, 33) if necessary. Inspect the gasket sealing surface for scratches or dents that may cause the gasket to leak.

NOTE

Spiral wound gaskets (Key 32) make their seal by being crushed. Spiral wound gaskets cannot be reused.

- 3 Inspect threads on bonnet studs (Key 34) and on packing studs (Key 13) for any damage.

Model 363 Control Valve

Operation, Parts, and Instruction Manual

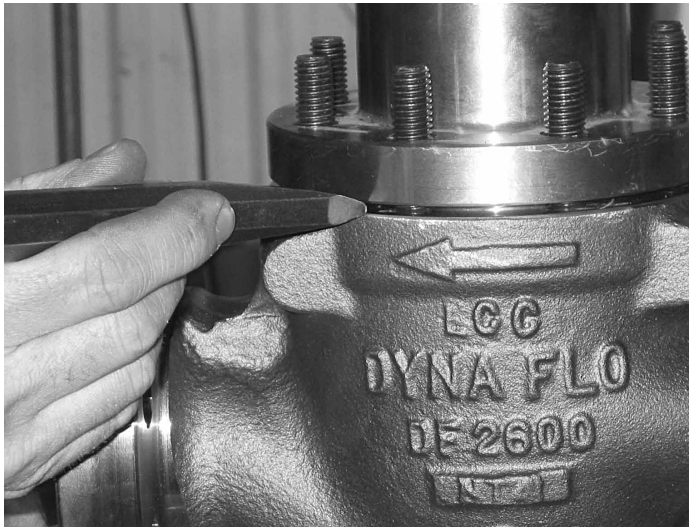

Figure 5 Body being separated with a chisel

Trim Parts Removal

Refer to Figures 10, 11, 12 & 13 for Key numbers
Regular / Extension Bonnets Stem / Plug and Seat Ring
Retainer Removal

NOTE

Some valve plug (Key 18) sizes / styles will not fit through the bushing (Key 25) portion of the seat ring retainer (Key 24). Use caution and determine the style / size of the valve plug present in the valve in order to proceed to the following steps.

For valve plugs that WILL slide through the bushing:

Simply Slide the valve stem / plug assembly (Keys 18, 20, 26) up through the bushing (Key 25) of the seat ring retainer (Key 24) and out of the valve body. Use caution not to damage any parts during removal.

For valve plugs that WILL NOT slide through the bushing:

Either support the valve stem / plug assembly (Keys 18, 20, 26) and slide the seat ring retainer (Key 24) up over the valve stem and out of the valve. Remove the valve stem / plug assembly from the valve.

Or, if easier, remove the valve stem / plug and seat ring retainer (Keys 18, 20, 24, 26) all at once. Once removed from the valve body slide the plug / stem assembly (Keys 18, 20, 26) out the bottom of the seat ring retainer (Key 24). Use caution not to damage any parts during removal.

Plug / Stem Disassembly

- 1 Once the plug / stem assembly (Keys 18, 20, 26) is removed from the valve, drive out the pin (Key 26) and unscrew the valve stem (Key 20) from the plug (Key 18). Perform only if necessary to change plug or stem.

Bellows Style Bonnet Assembly Stem / Plug and Seat Ring Retainer Removal

NOTE

Some valve plug (Key 18) sizes / styles will not fit through the bushing (Key 25) portion of the seat ring retainer (Key 24). Use caution and determine the style / size of the valve plug present in the valve in order to proceed to the following steps.

For valve plugs that WILL slide through the retainer bushing:

- 1 Slide the bellows stem / plug assembly (Keys 18, 19, 21, 26, 27) up through the seat ring retainer (Key 24) and out of the valve. If plug adapter and/or plug must be removed proceed to Step 2 of Disassembly **for valve plugs that WILL NOT slide through the retainer bushing.**
- 2 A razor or pick-set can be used to help remove the shim (Key 30) seat ring retainer gasket (Key 31) and spiral wound gasket (Key 32) if necessary.

NOTE

Spiral wound gaskets (Key 32) make their seal by being crushed. Spiral wound gaskets cannot be reused.

- 3 Remove the seat ring retainer (Key 24) and proceed to **Seat Ring & Gasket Removal.**

For valve plugs that WILL NOT slide through the bushing:

- 1 If the valve plug (Key 18) will not slide through the bushing (Key 25) of the seat ring retainer (Key 24) it will be necessary to remove the bellows style stem assembly (Key 21), plug (Key 18), gaskets (Keys 30-33) and seat ring retainer all at once. Be careful not to damage any parts during the removal process.



Model 363 Control Valve

Operation, Parts, and Instruction Manual

VALVE DISASSEMBLY (Continued)

Bellows Style Bonnet Assembly Stem / Plug and Seat Ring Retainer Removal (Continued)

For valve plugs that **WILL NOT** slide through the retainer bushing:

- 2 Once removed from the valve body, the valve plug adapter pin must be removed in order to remove the seat ring retainer (Key 24) from the bellows stem assembly (Key 21).
 - A Slide the seat ring retainer (Key 24) down towards the head of the valve plug (Key 18) as shown in Figure 12. Be sure to use jaw-softeners and place a portion of the valve plug (Key 18) or valve plug adapter (Key 19) that is not a sealing surface securely into a vise.
 - B It may be necessary to pull the bellows stem assembly (Key 21) back as shown in Figure 12 Detail 'A' in order to provide better access to the valve plug adapter pin (Key 27). Do not apply excessive force to pull back the bellows stem assembly, twist or perform any action that may damage the bellows. Drive out the adapter pin (Key 27) being careful not to damage parts in the process.
 - C Un-thread the valve plug adapter (Key 19) from the valve stem (Key 20).
- 3 Once the valve plug and adapter are removed (Keys 18, 19) slide the seat ring retainer (Key 24) and gaskets (Keys 30-33) off the valve stem. If necessary a razor or pick-set may be used to remove gaskets. Use caution not to damage any parts during removal.

Seat Ring & Gasket Removal

- 1 Remove the seat ring (Key 28) from the valve body.
- 2 A razor or a pick-set can be used to remove old gaskets.

CAUTION

Care must be taken to avoid damaging these surfaces.

NOTE

Spiral wound gaskets (Key 32) make their seal by being crushed. Spiral wound gaskets cannot be reused.

- 3 Inspect the internal body surfaces for any signs of corrosion, erosion or irregular wear.

Packing and Packing Parts Removal

CAUTION

Concentrated gases could be trapped in the packing!

- 1 Remove all packing parts (Keys 2-9) from the packing bore. Use a rounded tool to remove the packing set (Key 2) from the packing bore being careful not to damage the walls of the packing box. Clean all metal parts; if they are not damaged they can be reused.
- 2 Inspect the packing bore for any scratching or corrosion; minor scratching or pitting in the packing bore can be polished out.

Parts Inspection

It is important to inspect all parts of the valve for corrosion, wear and damage. Pay special attention to sealing surfaces and replace or repair parts as necessary.

- 1 Inspect the valve stem (Key 20) for any deep scratching or corrosion also inspect the threads for any damage. Minor scratching or corrosion is acceptable. A minor scratch can be defined as a scratch that will not stop your fingernail when you run it across the scratch. Anything other than a minor scratch will need to be sent to the factory to be refurbished back to the 4µin finish.
- 2 Inspect the seating area on the plug (Key 18). Some minor scratching or corrosion can be lapped out of the plug. The plug can be machined and lapped to remove damage caused by normal wear, corrosion or erosion.
- 3 Inspect the seat ring (Key 28) surface for any damage caused by erosion, corrosion or deep scratching. Minor scratching or corrosion can be removed by lapping or machining. Seat ring will need to be replaced if lapping or machining can not remove the damage. Also inspect the gasket-sealing surface for any damage.
- 4 Inspect the inside surface of the bushing (Key 25) and the sides of the plug for excessive wear or corrosion. Replace if necessary.

Model 363 Control Valve

Operation, Parts, and Instruction Manual



LAPPING

WARNING

Do not attempt to lap the seating surfaces on valves with a bellows style bonnet assembly. The bellows style bonnet assembly prevents stem rotation and the lapping procedure will damage the bellows.

Expect a certain amount of leakage in valves with metal seating. In some cases during maintenance or where leakage has become excessive, sealing performance of metal seats can be improved by lapping. Before proceeding with LAPPING process, inspect the plug / stem and seat as described in **Trim Parts Removal** (page 7).

NOTE

Spiral wound gaskets (Key 32) make their seal by being crushed. Spiral wound gaskets cannot be reused, this includes reusing a gasket after the lapping procedure has been performed. It may be desirable to use an "old" gasket for the lapping process and replace it after with a new gasket. CAUTION: after performing the lapping process with an "old" gasket it is important not to change the position of the seat ring (Key 28) or valve plug (Key 18)! Mark their position using a soft felt marker or similar method before removal. Failure to place trim parts back into their original lapped position after replacing the spiral wound gasket may result in excessive leakage.

- 1 Ensure all valve parts have been thoroughly cleaned before lapping. If the valve plug (Key 18) and seat ring (Key 28) have minor scratches on the seating surface, lapping can remove these scratches without having to replace or machine the plug or seat ring.
- 2 Trim parts should be installed according to the instructions presented in the Assembly: Trim Parts Assembly section, install the "old" seat ring gasket (Key 33), seat ring (Key 28), seat ring retainer (Key 24)(* see note), "old" spiral wound gasket (Key 32), shim (Key 30) and "old" seat retainer gasket (Key 31).

NOTE

It may be necessary with some plug sizes / styles to install the plug / stem assembly into the bushing / seat ring retainer assembly before installing the seat ring retainer into the valve body.

- 3 Apply fine grit lapping compound (400 – 600 grit) to the bottom of the valve plug and install the valve plug / stem assembly into the valve.
- 4 Place the bonnet (Key 1) over the stem and onto the valve. Secure the bonnet using 4 of the bonnet nuts (Key 35). It may be desirable to place the packing follower (Key 10) onto the valve stem and into the packing bore before constructing a handle, this will help keep the stem and plug centered. Attach a handle to the valve stem, such as one made using two wrenches and stem lock nuts as seen in Figure 6.
- 5 Rotate the valve plug (Key 18) in a clockwise then counter-clockwise direction using the handle (only a small amount of rotation is required). After a few cycles of rotation, disassemble the set up as necessary and mark the position of the cage, seat ring, and plug with a soft tip marker before changing out the gaskets. Test for shutoff and repeat lapping procedure if necessary.



Figure 6 Handle Construction for Lapping

ASSEMBLY

Ensure that all parts have been cleaned and inspected as per disassembly section.

Refer to Figures 10, 11, 12 & 13

Seat Ring and Gasket Assembly

NOTE

Use an anti-seize compound that is approved for the service conditions that the valve is being installed into.

- 1 Coat the seat ring gasket (Key 33) with nickle based anti-seize compound and insert it into the seat pocket in the body. Insert seat ring (Key 28) into seat pocket.



Model 363 Control Valve

Operation, Parts, and Instruction Manual

ASSEMBLY (Continued)

Regular / Extension Plug and Stem Assembly

For bellows style bonnet plug and stem assembly reference the **Bellows Style Bonnet Assembly** section.

NOTE

Instructions for assembling a valve plug adapter (Key 19) to a stem (Key 20) for use in a bellows style bonnet assembly are available in the Bellows Style Bonnet Trim Assembly section.

WARNING

It is inadvisable to reuse an old stem with a new valve plug, using a new plug requires drilling a new pin hole into the stem. A second pin hole into a valve stem will weaken the stem and cause failure. It is acceptable to use a new stem and old plug.

- 1 If a vice will be used to hold the stem (Key 20) or plug (Key 18) in place during drilling it will be necessary to use jaw softeners to avoid damaging the surfaces of either the stem or plug.
- 2 Thread the valve plug (Key 18) onto the appropriate end of the valve stem (Key 20) and tighten to the torque requirements specified in Table 2.
- 3 Select the appropriate drill size as indicated in Table 3 and drill entirely through the stem using the hole in the valve plug as a guide. Clean the plug and stem making sure that no burrs or metal chips remain to cause damage.
- 4 Drive a new valve plug pin (Key 26) into the plug and stem to secure the plug in place. Peen the edges of the hole to hold the pin in place.

Regular / Extension Bonnets Plug / Stem / Seat Ring Retainer Assembly

For valve plugs that WILL NOT slide through the bushing:

- 1 Slide the plug / stem assembly (Keys 18, 20, 26) up through the bushing (Key 25) of the seat ring retainer (Key 24) so the plug is situated in the seat ring retainer as shown in Figure 10.
- 2 Lift the plug / stem / seat ring retainer (Keys 18, 20, 24) all together and install them into the valve body (Key 17) so the seat ring retainer and plug are properly seated onto the seat ring (Key 28).

NOTE

Spiral wound gaskets (Key 32) make their seal by being crushed. Spiral wound gaskets cannot be reused.

- 3 Coat the shoulder of the seat ring retainer (Key 24) with nickel based anti-seize and install the spiral wound gasket (Key 32). Install the metal shim (Key 30) and seat retainer gasket (Key 31) applying anti-seize compound to each successive layer as they are installed.

For valve plugs that WILL slide through the bushing:

- 1 Install the seat ring retainer (Key 24) into the valve body so that it seats properly onto the seat ring (Key 28) as shown in Figures 10.

NOTE

Spiral wound gaskets (Key 32) make their seal by being crushed. Spiral wound gaskets cannot be reused.

- 2 Coat the shoulder of the seat ring retainer (Key 24) with nickel based anti-seize and install the spiral wound gasket (Key 32). Install the metal shim (Key 30) and seat retainer gasket (Key 31) applying anti-seize compound to each successive layer as they are installed.
- 3 Slide the valve plug / stem assembly (Keys 18, 20, 26) through the bushing (Key 25) of the seat ring retainer (Key 24) plug end first.

Bellows Style Bonnet Trim Assembly

Refer to Figure 11 & 12.

NOTE

Some valve plug (Key 18) sizes / styles will not fit through the bushing (Key 25) portion of the seat ring retainer (Key 24). Use caution and determine the style / size of the valve plug present in the valve in order to proceed to the following steps.

For valve plugs that WILL NOT slide through the bushing:

- 1 Coat the gasket surface of the seat ring retainer (Key 24) with nickel based anti-seize and install the spiral wound gasket (Key 32). Install the metal shim (Key 30) and seat retainer gasket (Key 31) applying anti-seize compound to each successive layer as they are installed onto the seat ring retainer.

Model 363 Control Valve

Operation, Parts, and Instruction Manual



- 2 Place the stem of the bellows stem assembly (Key 21) onto the seat ring retainer and gaskets as shown in Figure 12. Slide the seat ring retainer up the stem until the shoulder of the seat ring retainer seats onto the shoulder of the bellows stem assembly.
- 3 Support the entire assembly in a vice (use jaw softeners if necessary) and thread the valve plug adapter (Key 19) (complete with valve plug) onto the valve stem. Tighten the valve plug adapter onto the stem until the holes in the adapter align with the holes in the valve stem, it may be necessary to pull the seat ring retainer (Key 24) down the guide of the plug (Key 18) as seen in Figure 12 in order to accomplish this.
- 4 Use extreme caution when driving the adapter pin (Key 27) into the stem / adapter assembly (Keys 19, 21), it may be necessary to use a drive punch to make the process easier. Pushing the stem of the bellows stem assembly in towards the plug (Detail 'A' in Figure 12 shows the position of the set screws when the stem is pushed forward) will allow for better access to the plug adapter pin hole. Drive the adapter pin into the stem / plug adapter and peen the edges around the adapter pin hole in order to secure the pin in place.
- 5 Place the entire pinned plug / bellows stem assembly (Keys 18, 19, 21, 26, 27) into the valve body (Key 17) making sure that the plug (Key 18) and seat ring retainer (Key 24) seat properly onto the seat ring (Key 28). Coat the top gasket surface of the bellows stem assembly (Key 21) with nickel based anti-seize and install the bellows bonnet gasket (Key 29).
- 6 Coat the top of the bellows bonnet gasket (Key 29) with anti-seize and proceed to the Bonnet Assembly section.

For valve plugs that WILL slide through the bushing:

- 1 Thread the valve plug adapter (Key 19) onto the stem of the bellows stem assembly (Key 21) and tighten until the holes in the plug adapter and valve stem align. Support the bellows stem assembly in a vice (use jaw softeners if necessary) and drive the adapter pin (Key 27) into the stem assembly. Peen the edges of the adapter pin hole to secure the adapter pin (Key 27) in place.

- 2 Install the seat ring retainer (Key 24) into the valve body (Key 17) so that it seats properly onto the seat ring (Key 28). Coat the gasket surface of the seat ring retainer (Key 24) with nickel based anti-seize and install the spiral wound gasket (Key 32). Install the metal shim (Key 30) and seat retainer gasket (Key 31) applying anti-seize compound to each successive layer as they are installed onto the seat ring retainer.
- 3 Insert the plug / bellows stem assembly (Keys 18, 21) into the valve so that the plug slides through the bushing (Key 25) of the seat ring retainer (Key 24) and the bellows stem assembly seats properly onto the gasket surface of the seat ring retainer.
- 4 Coat the top gasket surface of the bellows stem assembly (Key 21) with nickel based anti-seize compound and install the bellows bonnet gasket (Key 29). Proceed to the **Bonnet Assembly** section.

Bonnet Assembly

NOTE

Spiral wound gaskets (Key 32) make their seal by being crushed. Spiral wound gaskets cannot be reused.

- 1 Coat gasket sealing surface on bonnet with nickel based anti-seize compound. Place bonnet (Key 1) over stem (Key 18) and tighten bonnet nuts (Key 35) to specified torque values. Follow standard torque sequence when tightening bolts. Refer to Table 1 for specific torque values.

Packing Assembly

Refer to Figure 8 & 9 for packing orientation and Key numbers for the following section.

- 1 Ensure all parts have been cleaned and inspected prior to replacing packing. (See **Disassembly** section for inspection procedures). Coat the threads of the packing studs (Key 13) with nickel based anti-seize and thread them into the top of the bonnet (Key 1).

NOTE

To prevent trapping air when installing packing rings it is necessary to add packing rings one at a time. Do not force packing rings below the chamfer of the packing bore before adding another ring. Packing should not be pushed down more than the thickness of the added ring (See Figure 7).



Model 363 Control Valve

Operation, Parts, and Instruction Manual

ASSEMBLY (Continued)

Packing Assembly (Continued)

For single style (spring-loaded) packing:

- A** Lubricate the packing box ring (Key 15) and lower wiper (Key 16) with silicone-based lubricant. Insert both parts into the packing bore followed by spring (Key 5) and special washer (Key 7).
- B** Lubricate the packing set (Key 2) with silicone-based lubricant and insert on top of the washer (Key 7) in the packing bore.
- C** Place the packing follower (Key 10) on top of the packing set followed by the upper wiper (felt) (Key 11) and packing flange (Key 12).
- D** Tighten the packing nuts (Key 14) until the packing follower comes into contact with the bonnet (Key 1).

For double style packing:

- A** Lubricate packing box ring (Key 15), lower wiper (Key 16) and lower packing set (Key 2) with silicone-based lubricant. Insert these parts into the packing bore followed by the lantern ring (Key 6).
- B** Lubricate the upper packing set (Key 2) and place it into the packing bore followed by the packing follower (Key 10).
- C** Insert the upper wiper (felt) (Key 11) and the packing flange (Key 12) over the stem (Key 20) and tighten the packing nuts (Key 14) to the proper torque value as specified in Table 2.

For double style graphite packing:

- A** Refer to Figures 8 & 9 for single and double packing arrangements. Choose proper arrangement based on stem size and single or double configurations. Install bonnet as described in the Assembly section. Install packing box ring and packing arrangement as shown. Note that Key 4 is graphite filament wound material that typically looks like rope. Key 3 is graphite ribbon compressed into rings and not split as the graphite filament ring is. Install packing follower (Key 10) and flange (Key 12) and torque as per Table 2.

CAUTION

Graphite ribbon packing damages easily, care is to be taken when installing it into the packing bore.

For live loaded packing:

- A** Lubricate the packing box ring (Key 15) with silicone based lubricant and insert it into the packing bore.
- B** Install other packing parts according to the packing styles as seen in Figure 8 & 9. Be sure to lubricate the packing set (Key 2) with silicone based lubricant if set is present in assembly. Refer to **NOTE** on preventing trapped air between packing.
- C** Place the live loaded packing follower (Key 10) on top of the packing followed. Install the spring washers (Key 8) onto the packing follower (Key 10) orientated as shown in Figure 8. Slide the packing o-ring (Key 9) onto the packing follower so that it rests on the top spring washer.
- D** Install the packing flange (Key 12) onto the packing follower (Key 10). Apply nickel based anti-seize compound to the threads of the packing studs (Key 13) and thread the packing nuts (Key 14) onto the studs finger tight to the packing flange.
- E** Tighten the packing nuts (Key 14) evenly and alternately keeping the packing flange parallel with the top of the bonnet (Key 1) until the spring washers (Key 8) are compressed flat. Loosen each packing flange nut by a half turn (180° of rotation) to give the live loaded packing the target load of 85% compression.

Model 363 Control Valve

Operation, Parts, and Instruction Manual

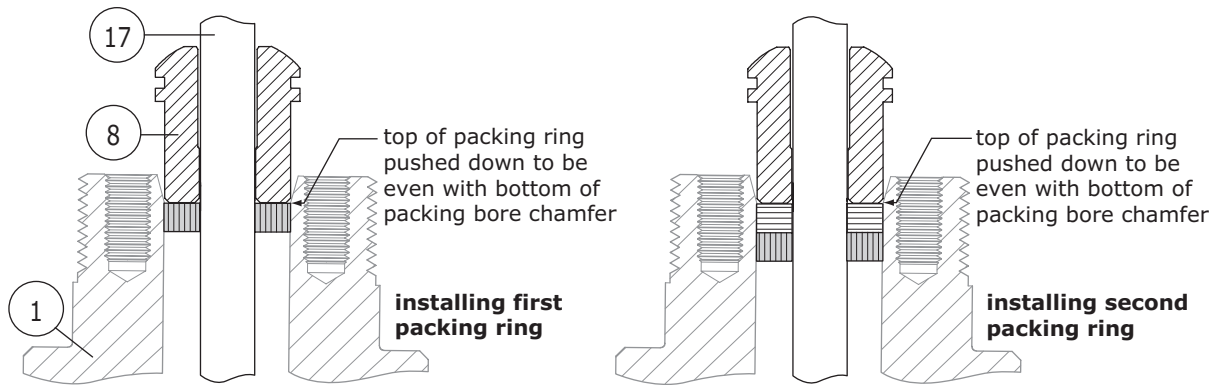

Figure 7 Packing Ring Installation

Table 1

Body to Bonnet Stud Torque				
Valve Sizes (Inch)	Bolt Torques			
	B7 B7 Fluorokote #1		B7M B7M Fluorokote #1 B8M CL2 (strain hardened)	
	N•m	lbf-ft.	N•m	lbf-ft.
1	127	94	102	75
1-1/2 & 2	88	65	71	52

Table 2

Packing Nut Torque Values									
Valve Stem Diameter Inch (mm)	ASME Class	PTFE Single and Double Type Packing				Graphite Single and Double Type Packing			
		Min. Torque		Max. Torque		Min. Torque		Max. Torque	
		lbf-in.	N•m	lbf-in.	N•m	lbf-in.	N•m	lbf-in.	N•m
3/8 (9.5)	150	9	1	17	2	27	3	44	5
	300	17	2	27	3	35	4	53	6
	600	27	3	35	4	53	6	71	8
1/2 (12.7)	150	17	2	35	4	44	5	71	8
	300	27	3	44	5	58	7	89	10
	600	35	4	58	7	80	9	124	14
3/4 (19.1)	150	44	5	71	8	97	11	150	17
	300	62	7	97	11	133	15	204	23
	600	89	10	133	15	186	21	274	31



Model 363 Control Valve

Operation, Parts, and Instruction Manual

Table 3

Valve Stem Connection Assembly Torque and Pin Replacement

Valve Stem Diameter Inches (mm)	Torque lbf-ft. (N·m)		Hole Size Inches (mm)	'B' Dimension ⁽¹⁾ Inch (mm)
	Minimum	Maximum		
3/8 (9.5)	25 (40)	35 (47)	3/32 (2.4)	5/8 (16)
1/2 (12.7)	60 (81)	85 (115)	1/8 (3.2)	3/4 (19)
3/4 (19.1)	175 (237)	250 (339)	3/16 (4.8)	1 (25.4)

1 - Refer to Figure 14 on Page 19 for Hole Dimension Diagram

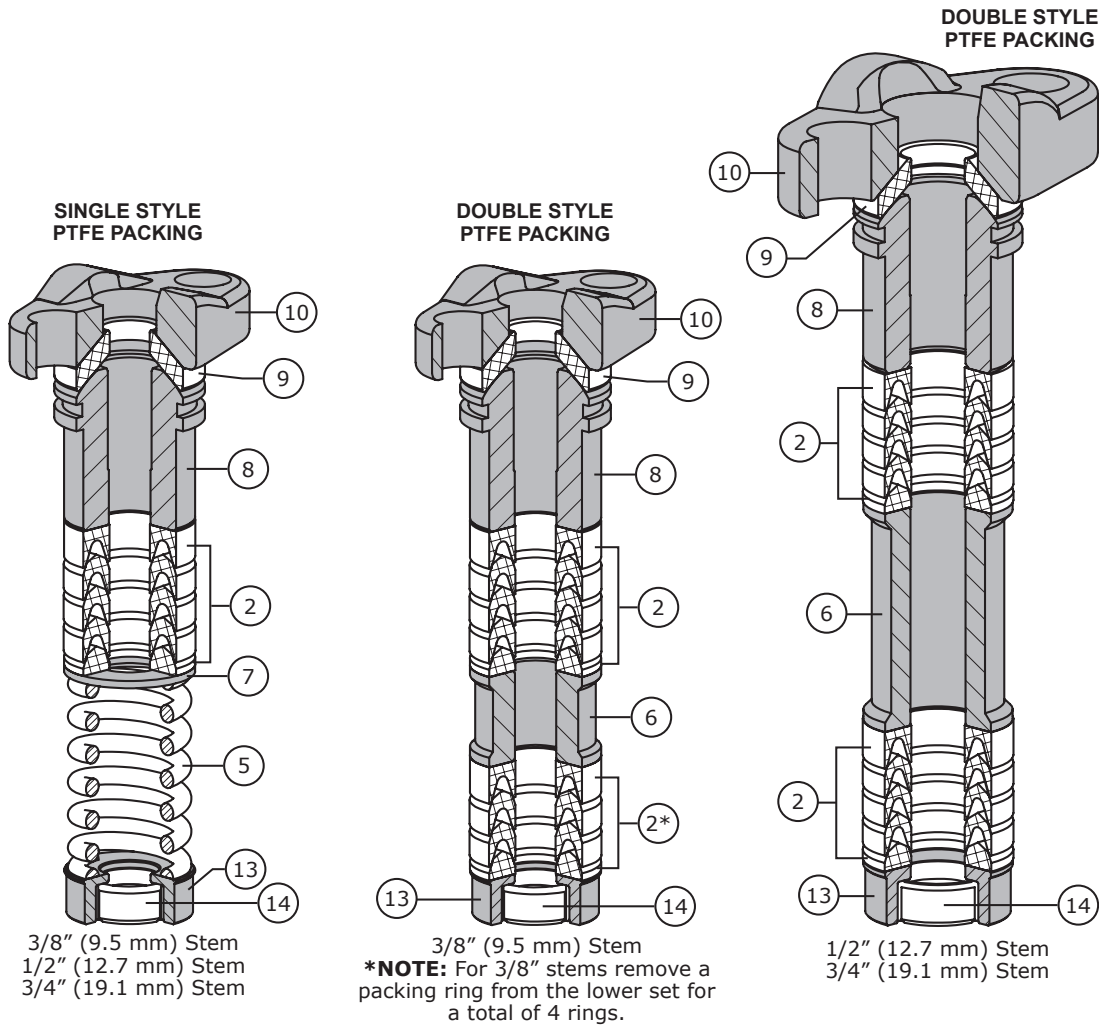

Figure 8 Model 363 Control Valve PTFE Packing Diagrams

Model 363 Control Valve

Operation, Parts, and Instruction Manual

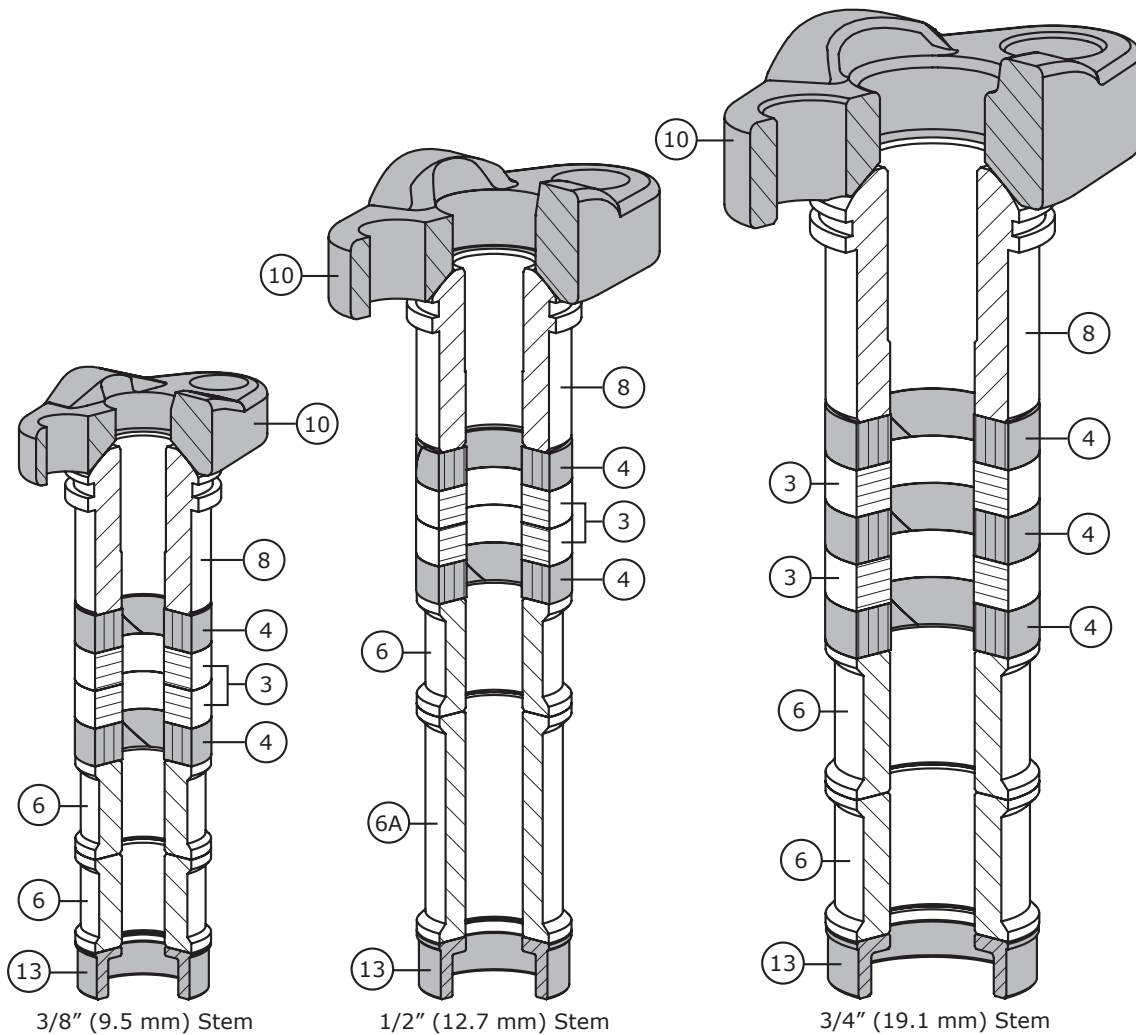

Figure 9 Model 363 Control Valve Single Style Graphite Packing Diagrams



Model 363 Control Valve

Operation, Parts, and Instruction Manual

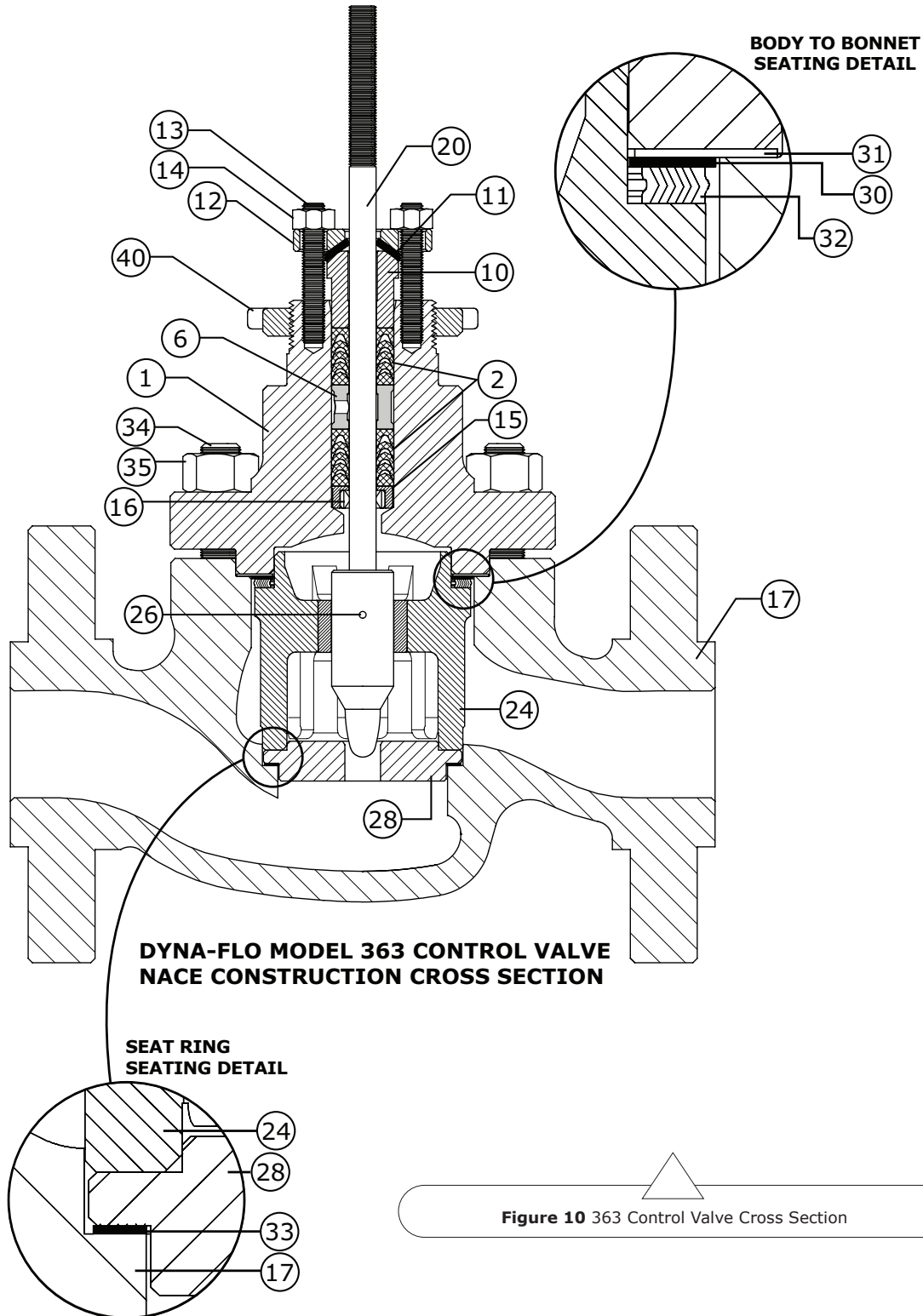

Figure 10 363 Control Valve Cross Section

Model 363 Control Valve

Operation, Parts, and Instruction Manual

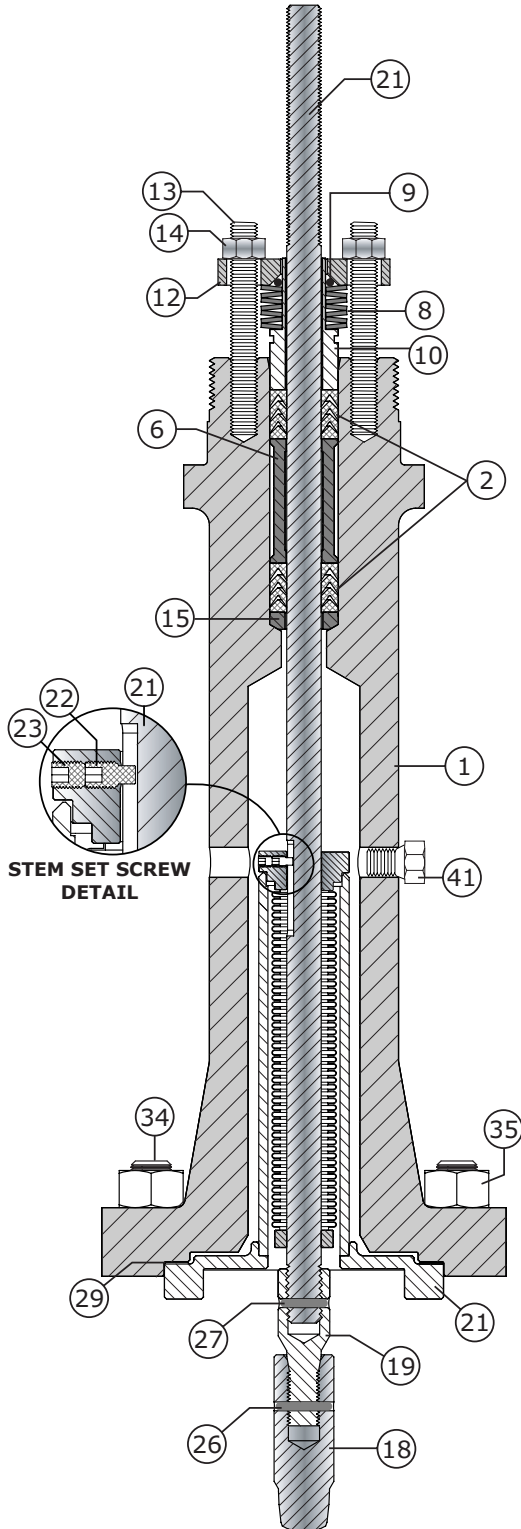
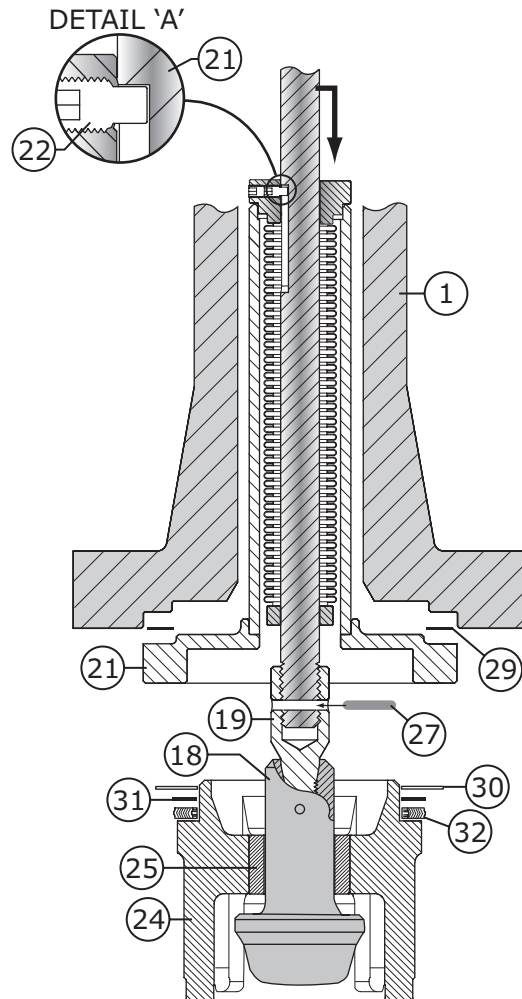

Figure 11 363 Control Valve Bellows Style Bonnet Assembly Diagram

For Bellows Bonnet valves 150 - 300 Class maximum pressure is 300 Psig at 350°F.

Figure 12 363 Control Valve Large Plug Assembly Diagram





Model 363 Control Valve

Operation, Parts, and Instruction Manual

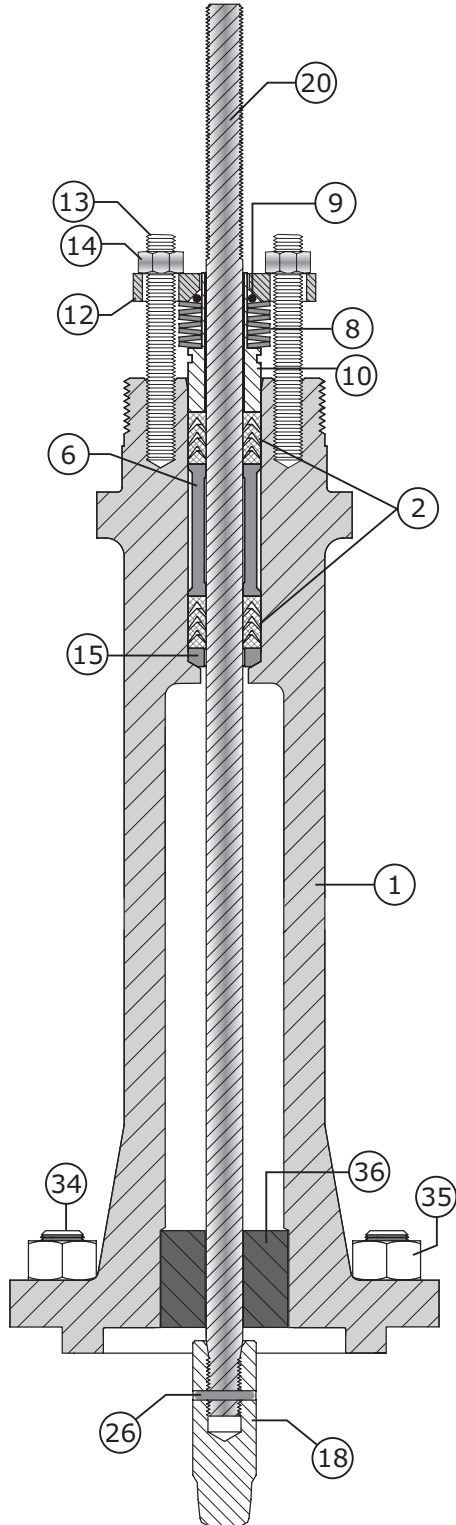
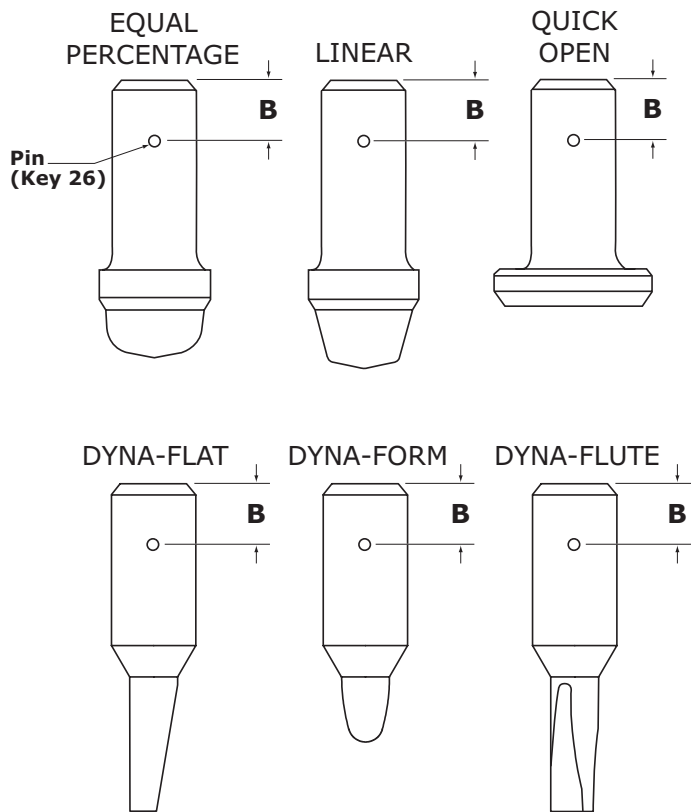

Figure 13 363 Control Valve Extension Bonnet Diagram

Figure 14 363 Control Valve Plug Characteristic Diagram



*Refer to Table 3 for 'B' dimensions

Model 363 Control Valve

Operation, Parts, and Instruction Manual



Parts

Key	Description	Part Number
1	Bonnet if you need a bonnet as a replacement part, order by valve size and stem diameter, serial number and desired material.	
2 - 9	Packing Parts Refer to Packing Box Parts Table 5.	
10	Packing Follower S31600/S31603 Dual Grade 3/8" (9.5 mm) Stem 1/2" (12.7 mm) Stem 3/4" (19.1 mm) Stem Live Loaded Packing Follower S31600/S31603 Dual Grade 3/8" (9.5 mm) Stem 1/2" (12.7 mm) Stem 3/4" (19.1 mm) Stem	1E94393507D 1E94433507D 1E94473507D LLP375FLWRD LLP500FLWRD LLP750FLWRD
11	Upper Wiper Felt 3/8" (9.5 mm) Stem 1/2" (12.7 mm) Stem 3/4" (19.1 mm) Stem	1J87260633D 1J87270633D 1J87280633D
12	Packing Flange Carbon Steel (Plated) 3/8" (9.5 mm) Stem 1/2" (12.7 mm) Stem 3/4" (19.1 mm) Stem S31600/S31603 Dual Grade 3/8" (9.5 mm) Stem 1/2" (12.7 mm) Stem 3/4" (19.1 mm) Stem Live Loaded Packing Flange S31600/S31603 Dual Grade 3/8" (9.5 mm) Stem 1/2" (12.7 mm) Stem 3/4" (19.1 mm) Stem	1E94372410D 1E94422307D 1E94482307D 1E94373507D 1F38033507D 1F38043507D 12B6923X01D 12B6924X01D 12B6925X01D
13	Packing Stud (2 Required) B7 3/8" (9.5 mm) Stem 1/2" (12.7 mm) Stem 3/4" (19.1 mm) Stem	1E94413103D 1E94443103D 1E94493103D

Key	Description	Part Number
13	Packing Stud (Continued) B8M 3/8" (9.5 mm) Stem 1/2" (12.7 mm) Stem 3/4" (19.1 mm) Stem Live Loaded Packing Stud B8M 3/8" (9.5 mm) Stem 1/2" (12.7 mm) Stem 3/4" (19.1 mm) Stem	1E94413522D 1E94443522D 1E94493522D 1E94413522D 1E94443522D 1E94493522D
14	Packing Nut (2 Required) 2H 3/8" (9.5 mm) Stem 1/2" (12.7 mm) Stem 3/4" (19.1 mm) Stem 8M 3/8" (9.5 mm) Stem 1/2" (12.7 mm) Stem 3/4" (19.1 mm) Stem	1E94402411D 1E94452411D 1E94462411D 1E94403525D 1E94453525D 1E94463525D
15	Packing Box Ring S31600/S31603 Dual Grade 3/8" (9.5 mm) Stem 1/2" (12.7 mm) Stem 3/4" (19.1 mm) Stem	1J87313507D 1J87323507D 1J87333507D
16	Lower Wiper Teflon 3/8" (9.5 mm) Stem 1/2" (12.7 mm) Stem 3/4" (19.1 mm) Stem	1J87210699D 1J87220699D 1J87230699D
17	Body if you need a body as a replacement part, order by valve size and stem diameter, serial number and desired material.	
18	Valve Plug	Refer to Table 8
19	Valve Plug / Stem Adapter S31600/S31603 Dual Grade 1/2" to 3/8" 1/2" to 1/2" 3/4" to 3/4"	363BSS375AD 363BSS500AD 1U2265NT50D
20	Valve Stem (Standard Bonnet) S20910 3/8" (9.5 mm) Stem 1/2" (12.7 mm) Stem 1/2" to 3/8" Stem	1U3888NT50D 1U3889NT50D 1U5309NT50D



Model 363 Control Valve

Operation, Parts, and Instruction Manual

Parts (Continued)

Key	Description	Part Number
21	Bellows Stem Assembly	
	S31600/S31603 Dual Grade / N06625	
	1 Inch Valve	363BSS100D
	1-1/2 Inch Valve	363BSS150D
	2 Inch Valve	363BSS200D
22	Stem Set Screw	
	Stainless Steel	363SSFD020D
23	Stem Screw Retainer	
	Stainless Steel	363SSDP030D
24 -25	Seat Ring Retainer / Bushing Assembly	
	S31600 / Alloy 6	
	1 Inch Valve	25A6683X07D
	1-1/2 Inch Valve	25A6685X08D
	2 Inch Full Port	25A6687X11D
	2 Inch Restricted	25A6687X13D
	S31600 / S17400 DH1150	
	1 Inch Valve	25A6683X06D
	1-1/2 Inch Valve	25A6685X07D
	2 Inch Full Port	25A6687X06D
	2 Inch Restricted	25A6687X09D
26	Plug Pin	
	S31600	
	3/8" Valve Stem Connection	1V32263507D
	S30400	
	1/2" Valve Stem Connection	1V32273507D
	3/4" Valve Stem Connection	1V32603507D
27	Adapter Pin	
	S30400	1V32273507D
28	Seat Ring	Refer to Table 6
29	Bellows Bonnet Gasket	
	Graphite	
	1 Inch Valve	363GSKT100D
	1-1/2 Inch Valve	363GSKT150D
	2 Inch Valve	363GSKT200D
30	Shim	
	S30400	
	1 Inch Valve	16A1936X01D
	1-1/2 Inch Valve	16A1937X01D
	2 Inch Valve	16A1938X01D

Key	Description	Part Number
31	Bonnet Retainer Gasket	
	S31600 / Graphite	
	1 Inch Valve	1R2859X004D
	1-1/2 Inch Valve	1R3101X003D
	2 Inch Valve	1R3299X004D
32	Spiral Wound Gasket	
	N06600 / Graphite	
	1 Inch Valve	
	1-1/2 Inch Valve	
	2 Inch Valve	
33	Seat Ring Gasket	
	S31600 / Graphite	
	1 Inch Valve	1R2862X011D
	1-1/2 Inch Valve	1R3098X005D
	2 Inch Valve	1R3296X004D
34	Body / Bonnet Stud	
	S17400 DH1150	
	1 Inch Valve (4 Required)	1R2848X174D
	1-1/2 Inch Valve (8 Required)	1K242917-4D
	2 Inch Valve (8 Required)	1K2429X174D
	B7	
	1 Inch Valve (4 Required)	1R2848X057D
	1-1/2 Inch Valve (8 Required)	1K2429X056D
	2 Inch Valve (8 Required)	1K2429X056D
	B7M	
	1 Inch Valve (4 Required)	1R2848B7MDD
	1-1/2 Inch Valve (8 Required)	1K2429B7MDD
	2 Inch Valve (8 Required)	1K2429B7MDD
	B8M	
	1 Inch Valve (4 Required)	1R2848CL28D
	1-1/2 Inch Valve (8 Required)	1K2429CL28D
	2 Inch Valve (8 Required)	1K2429CL28D
35	Body / Bonnet Nut	
	2H	
	1 Inch Valve (4 Required)	1C33062407D
	1-1/2 Inch Valve (8 Required)	1A3772X066D
	2 Inch Valve (8 Required)	1A3772X066D
	2HM	
	1 Inch Valve (4 Required)	1C33062HMDD
	1-1/2 Inch Valve (8 Required)	1A37722HMDD
	2 Inch Valve (8 Required)	1A37722HMDD

Model 363 Control Valve

Operation, Parts, and Instruction Manual



Parts (Continued)

Key	Description	Part Number
35	Body / Bonnet Nut (Continued)	
	B8M	
	1 Inch Valve (4 Required)	1C33063525D
	1-1/2 Inch Valve (8 Required)	1A3772X023D
	2 Inch Valve (8 Required)	1A3772X023D
36	Baffle (Bonnet Bushing)	
	3/8" (9.5 mm) Stem	10A9210X01D
	1/2" (12.7 mm) Stem	1R33602449D
	3/4" (19.1 mm) Stem	1R35182449D
37	Drive Screw (6 Required)	

Key	Description	Part Number
38	Nameplate	
	S30400	NAME12SL1DD
39	Flow Arrow	
	S30400	1V10603898D
40	Yoke Nut	
	Steel Plated	
	3/8" (9.5 mm) Stem	1E79302306D
	1/2" (12.7 mm) Stem	1E80742306D
	3/4" (19.1 mm) Stem	1E83272306D
41	Bonnet Pipe Plug (1/4" NPT)	
	S31600	1A76753507D

Table 4

Packing Box Parts (Keys 2, 3, 4, 5, 6, 7, 7A, 8, & 9)

Description	Key No.	Stem Diameter inch (mm)			
		3/8 (9.5)	1/2 (12.7)	3/4 (19.1)	
PTFE V-Ring Packing	Packing Set (PTFE) (Refer to Table 11 for Repair Kits) ¹	2	1R29000101D	1R2902010DD	1R2904010DD
	Spring (S30400) (for single only)	5	1F12543701D	1F12553701D	1F12563701D
	Lantern Ring (S31600/S31603) (for double only)	6	DFX0000031D	DFX0000001D	DFX0000041D
	Quantity Required	Double Packing	1	1	1
	Special Washer (S30400) (for Single only)	7	1F12523604D	1F12513604D	1F12503604D
Graphite Ribbon / Graphite Filament	Graphite Ribbon (Ring)	3	1V3160X002D	1V3802X002D	1V2396X002D
	Quantity Required	Single Packing	2	2	2
	Graphite Filament (Ring)	4	1F3370X032D	1E3190X022D	1E191X028D
	Quantity Required	Single Packing	2	2	3
	Lantern Ring (S31600/S31603)				
	Quantity Required	Single Packing	6	2	1
		(6A)	DFX0000031D	DFX0000021D	DFX0000041D
			-	1	-
				DFX0000001D	
Live Loaded Packing	Keys 7A, 8, & 9 Contact Dyna-Flo Control Valve Services Ltd.				

1 - For 3/8 inch stems, remove a packing ring from the lower set for a total of 4 rings.



Model 363 Control Valve

Operation, Parts, and Instruction Manual

Table 5

Packing Repair Kits

Stem Diameter [Yoke Boss Diameter] Inches (mm)	Single		Double
	PTFE	Graphite	PTFE
3/8 (10) [2-1/8 (54)]	RPACKX0001D	RPACKX0010D	RPACKX0004D
1/2 (12.7) [2-13/16 (71)]	RPACKX0002D	RPACKX0011D	RPACKX0005D
3/4 (19.1) [3-9/16 (90)]	RPACKX0003D	RPACKX0012D	RPACKX006D

Table 6

Keys 30, 31, 32, & 33 Gasket Kits (Quantity 4/kit)

Description	Part Number
1 inch	
1-1/2 inch	
2 inch	

Table 7

Key 28 Seat Ring

Valve Size Inch	Port Diameter Inch (mm)	Seat Ring Material		
		S41600 HT	S31600/S31603	S31600/S31603 / Alloy 6
1	3/16 (4.8)	1V10834617D	1V10833507D	2V62625033D
	1/4 (6.4)	1U28524617D	1U28523507D	2U85594605D
	3/8 (9.5)	1U28534617D	1U28533507D	2U85604605D
	1/2 (12.7)	1U28544617D	1U28543507D	2U85614605D
	3/4 (19.1)	1U28554617D	1U28553507D	2U85624605D
	1 (25.4)	1U28564617D	1U28563507D	2U85634605D
1-1/2	3/16 (4.8)	15A6512X05D	15A6512X01D	25A8564X01D
	1/4 (6.4)	15A6513X05D	15A6513X01D	15A6537X01D
	3/8 (9.5)	17A6075X05D	17A6075X01D	27A6076X01D
	1/2 (12.7)	15A6514X05D	15A6514X01D	15A6538X01D
	3/4 (19.1)	16A3350X05D	16A3350X01D	26A3351X01D
	1 (25.4)	15A6515X05D	15A6515X01D	15A6654X01D
	1.5 (38.1)	15A6504X05D	15A6504X01D	15A6655X01D
2	3/16 (4.8)	15A6692X05D	15A6692X01D	25A8565X01D
	1/4 (6.4)	15A6693X05D	15A6693X01D	25A6698X01D
	3/8 (9.5)	17A4091X01D	17A4091X02D	27A6080X01D
	1/2 (12.7)	15A6694X05D	15A6694X01D	25A6699X01D
	3/4 (19.1)	16A3353X05D	16A3353X01D	26A3354X01D
	1 (25.4)	15A6695X05D	15A6695X01D	25A1085X01D
	2 (50.8)	15A6505X05D	15A6505X01D	15A6656X01D

Model 363 Control Valve

Operation, Parts, and Instruction Manual



Table 8

Key 18 Valve Plugs

Valve Size (Inch)	Valve Plug Style	Port Diameter Inch (mm)	Valve Stem Connection Inch (mm)	Material			
				S41600 HT	S31600 / S31603	S31600/S31603 / Alloy 6 Seat	S31600/S31603 / Alloy 6 Seat and Guide
1 1-1/2 2	Equal Percentage	1 (25.4)	3/8 (9.5)	15A6480X05D	15A6480X01D	15A6634X01D	15A6635X01D
			1/2 (12.7)	15A6481X05D	15A6481X01D	15A6636X01D	15A6637X01D
	Linear	1 (25.4)	3/8 (9.5)	15A6470X05D	15A6470X01D	15A6614X01D	15A6615X01D
			1/2 (12.7)	15A6471X05D	15A6471X01D	15A6616X01D	15A6617X01D
	Quick Opening	1 (25.4)	3/8 (9.5)	15A6490X05D	15A6490X01D	15A6516X01D	15A6517X01D
			1/2 (12.7)	15A6491X05D	15A6491X01D	15A6518X01D	15A6519X01D
	Dyna-Form	1/4 (6.4) 3/8 (9.5) 1/2 (12.7) 3/4 (19.1)	3/8 (9.5)	15A6500X05D	15A6500X01D	15A6663X01D	15A6664X01D
				16A5708X05D	16A5708X01D	16A5713X01D	16A5711X01D
				15A6502X05D	15A6502X01D	15A6659X01D	15A6660X01D
				16A3335X05D	16A3335X01D	16A3337X01D	16A3339X01D
		1/4 (6.4) 3/8 (9.5) 1/2 (12.7) 3/4 (19.1)	1/2 (12.7)	15A6501X05D	15A6501X01D	—	—
				16A5709X05D	16A5709X01D	16A5714X01D	16A5712X01D
				15A6503X05D	15A6503X01D	15A6661X01D	15A6662X01D
				16A3336X05D	16A3336X01D	16A3338X01D	16A3340X01D
Dyna-Flat	3/16 (4.8)	3/8 (9.5)	1V10814617D	2V92695X01D	—	2v92695033D	
Dyna-Flute (1 Flute)	1/4 (6.4)	3/8 (9.5)	1U84454617D	2U86823516D	—	2U86824642D	
Dyna-Flute (3 Flute)	1/4 (6.4)	3/8 (9.5)	1U84474617D	2U86844X01D	—	2U86844642D	
1-1/2	Equal Percentage	1-1/2 (38.1)	3/8 (9.5)	15A6482X05D	15A6482X01D	15A6638X01D	15A6639X01D
			1/2 (12.7)	15A6483X05D	15A6483X01D	15A6640X01D	15A6641X01D
	Linear	1-1/2 (38.1)	3/8 (9.5)	15A6472X05D	15A6472X01D	15A6618X01D	15A6619X01D
			1/2 (12.7)	15A6473X05D	15A6473X01D	15A6620X01D	15A6621X01D
	Quick Opening	1-1/2 (38.1)	3/8 (9.5)	15A6492X05D	15A6492X01D	15A6520X01D	15A6521X01D
			1/2 (12.7)	15A6493X05D	15A6493X01D	15A6522X01D	15A6523X01D
2	Equal Percentage	2 (50.8)	1/2 (12.7)	15A6484X05D	15A6484X01D	15A6642X01D	15A6643X01D
			3/4 (19.1)	15A6485X05D	15A6485X01D	15A6644X01D	15A6645X01D
	Linear	2 (50.8)	1/2 (12.7)	15A6474X05D	15A6474X01D	15A6622X01D	15A6623X01D
			3/4 (19.1)	15A6475X05D	15A6475X01D	15A6624X01D	15A6625X01D
	Quick Opening	2 (50.8)	1/2 (12.7)	15A6494X05D	15A6494X01D	15A6524X01D	15A6525X01D
			3/4 (19.1)	15A6495X05D	15A6495X01D	15A6526X01D	15A6527X01D

Parts Ordering

Whenever corresponding with Dyna-Flo about a 363 Control Valves, refer to the nameplate for the serial number of the unit. Please order by the complete part number (as given in the part lists) of each part required.



Model 363 Control Valve

MODEL NUMBERING SYSTEM

SAMPLE PART NUMBER: 363-2AFL-108P2-ES4

VALVE SIZE					2			
9	1/2 INCH	7	3/4 INCH	1		1 INCH	5	1-1/2 INCH
2	2 INCH							
ASME RATING					A			
A	150	B	300	C		600		
END CONNECTION					F			
F	RF	J	RTJ	N		NPT	T	BWE SCH 40
L	BWE SCH 80		S		SOCKET WELD			
BODY MATERIAL					L			
L	LCC	W	WCC	M		CF8M	9	WC9
BOLTING					-			
-	B7 / 2H (STANDARD)			A		B7M / 2HM		
B	B8M / 8M			K		B7 / 2H FLUOROKOTE #1		
L	B7M / 2HM FLUOROKOTE #1							
TRIM					1			
1	TRIM Z1	2	TRIM Z2	3		TRIM Z3	4	TRIM Z4
6	TRIM Z6	7	TRIM Z7	8		TRIM Z8	9	TRIM Z9
B	TRIM ZB	F	TRIM ZF	N		TRIM ZN	R	TRIM ZR
PORT SIZE					08			
01	3/16 INCH PORT	02	1/4 INCH PORT	03		3/8 INCH PORT	04	1/2 INCH PORT
06	3/4 INCH PORT	08	1 INCH PORT	12	1-1/2 INCH PORT	16	2 INCH PORT	
PACKING STYLE					P			
P	SINGLE PTFE V-RING (PRESSURE)			J		DOUBLE PTFE V-RING (PRESSURE)		
G	SINGLE GRAPHITE (PRESSURE)			V		DOUBLE PTFE V-RING (VACUUM)		
R	DOUBLE PTFE V-RING (VACUUM / PRESSURE)			L		LIVE LOADED PTFE V-RING (PRESSURE)		
T	LIVE LOADED GRAPHITE (PRESSURE)			D		LIVE LOADED DUPLEX (PRESSURE)		
K	LIVE LOADED KALREZ®							
YOKE BOSS SIZE					2			
1	2-1/8" (3/8" STEM)		2	2-13/16" (1/2" STEM)		3	3-9/16" (3/4" STEM)	
PAINT					-			
-	DFPS-01 (STANDARD)			2		DFPS-02 (SEVERE SERVICE)		
3	DFPS-03 (HIGH TEMPERATURE)							
CHARACTERISTIC					E			
E	EQUAL PERCENT (FULL PORT)			Q		QUICK OPENING (FULL PORT)		
L	LINEAR (FULL PORT)			M		DYNA-FORM		
G	DYNA-FLUTE - 1 FLUTE			F		DYNA-FLUTE - 3 FLUTE		
D	DYNA-FLAT (1D)			C		DYNA-FLAT (1D 8M)		
A	DYNA-FLAT (1D 55M)			H		DYNA-FLAT (3D25M)		
BONNET STYLE					S			
S	STANDARD			T		STANDARD TAPPED		
E	EXTENSION STYLE 1			H		EXTENSION STYLE 2		
B	BELLOWS SEAL							
SHUT-OFF CLASS					4			
4	CLASS IV	5	CLASS V	6		CLASS VI		

363

Our Commitment to Quality

Curtiss-Wright Flow Control Company Canada is committed to continuous improvement. While all efforts have been made to ensure the accuracy of the content in this document, modifications or improvements to the information, specifications, and designs may occur at any time without notice. This document was published for informational purposes only, and does not express or imply suitability, a warranty, or guarantee regarding the products or services described herein or their use or applicability.

Neither Curtiss-Wright Flow Control Company, nor any of their affiliated entities assumes responsibility for the selection, use and maintenance of any product. Responsibility for selection, use and maintenance of any product remains with the purchaser and end-user.