

Model 392 Control Valves

Technical Sales Bulletin



Figure 1 Model 392 Control Valve with DFC Actuator

The Model 392 control valves (Figure 1) are heavy duty globe style control valves. This valve is used in all kinds of demanding applications, including oil and gas production and chemical process industry. Metal seats are used for increased seat life.

Model 392 valves are unbalanced cage guided, single port valves that can be used in either snap on/off acting or throttling applications of either liquids or gases. A bolted bonnet is standard and a typical actuator is a Dyna-Flo Model DFC or DFO linear actuators.

Features

Valve Sizes and Connections

The 392 valve is available in 1" and 2" sizes with ASME 900/1500 raised face (RF), ring type joint (RTJ), butt weld (BWE), and socket weld (SWE) connections.

High Temperature Option

The standard temperature of 450°F (232°C) can be increased with high temperature options.

Low Temperature Service Option

Optional materials and trim details can be used to make the model 392 suitable for low temperature service.

Pressure Drop Capabilities

The Model 392 can shut off against inlet pressure equal to ASME B16.34 rating.

Sour Gas Service Capability

The Model 392 can be constructed out of materials that comply with the recommendations of the National Association of Corrosion Engineers (NACE) MR-0175/ ISO 15156.

Shut Off Classification

Seat leakage options range from standard ANSI/FCI 70.2 and IEC 60534-4 Class IV and optional Class V shut off.

Flow Characteristics Selections

The standard flow characteristic is equal percentage. However, linear, and modified equal percent are also available.



Model 392 Control Valves

Technical Sales Bulletin

SPECIFICATIONS

Configurations

The Model 392 control valve is a high capacity single port, globe style valve with a bolted type bonnet. The standard valve plug action is push down to close. Refer to Table 1.

Consult your Dyna-Flo sales office for other available configurations.

Sizes and Connection Styles (Refer to Table 1)

Models:	392
Size:	1" & 2"
Body:	Globe (All Sizes), Angle (All Sizes)
Rating:	ASME Class 900 & 1500
Connections:	RF / RTJ / BWE / SWE- All Sizes

Maximum Inlet Temperature and Pressures

Flanged and welded valves consistent with ASME Class 900/1500 rating as per ASME B16.34, unless limited by either material pressure and temperature limitations.

Maximum Pressure Drops

- Standard Valve Trim:** Refer to Figure 8.
- Anti-Cavitation 2 Stage Trim:** 2,160 Psi (149 bar).
- Anti-Cavitation 3 Stage Trim:** 3,000 Psi (207 bar).
- Low-Noise Valve Trim:** Figure 8.

Characteristic and Flow Direction (Refer to Table 5)

- Equal Percentage (Standard) - Normally Flow Up
- Modified Equal Percentage - Normally Flow Up
- Linear - Normally Flow Up
- Dyna-Form - Flow Up Only
- Low-Noise III (Linear) - Flow Up
- Anti-Cavitation 1-Stage (Linear) - Flow Down
- Anti-Cavitation 2-Stage (Linear) - Flow Down

NOTE: 392 Valves may be used as flow down for on/off service only. 392 valves may also be used as flow down for erosive service.

Dimensions

Valve and Actuator Outline Dimension Diagram

Refer to Figure 2.

Valve and Actuator Assembly Dimensions

Refer to Tables 6 to 11.

Approximate Valve Body and Actuator Weights

Refer to Table 3.

Materials

Body and bonnet material options include:

- LCC (A350-LF2 optional* bonnet material)
- WCC (A350-LF2 optional* bonnet material)
- WC9 (A182-F22 optional* bonnet material)
- CF8M (A182-F316 optional* bonnet material)

***NOTE:** Dyna-Flo reserves the right to substitute a cast material with the forged bar equivalent in the event a casting is not available.

Refer to Figure 8 for valve construction material temperature limitations. Refer to Table 14 for trim selections.

Cross-Section of the Model 392 Control Valves

Refer to Figure 3.

Port Diameters and Maximum Valve Plug Travel

Refer to Tables 4 and 5.

Packing Type and Example

The Standard packing is PTFE V-ring. Live-loaded low emission, graphite, KALREZ® and other packing arrangements are available. Refer to Figure 7.

Maximum Valve Sizing Coefficients

For standard coefficients at maximum travel, refer to Table 15 & 16. For full list of coefficients refer to document P-CVSM.

Service Application

Refer to Tables 12 - 14.

For more information and other options contact your Dyna-Flo sales office.

Model 392 Control Valves

Technical Sales Bulletin



Table 1

Available Valve Configurations

Valve Model	Valve Size Inch	End Connection		
		RF ⁽¹⁾ and RTJ ⁽²⁾ (Flanged)	BWE ⁽³⁾	SWE ⁽⁴⁾
		ASME Class 900/1500		
392	1	✓	✓	✓
	2	✓	✓	✓
392A	1	✓	✓	✓
	2	✓	✓	✓
Notes:	1 - RF = Raised Face.			
	2 - RTJ = Ring Type Joint.			
	3 - BWE = Butt Weld (ASME Class 900/1500).			
	4 - SWE = Socket Weld (ASME Class 900/1500).			

Table 2

Standard Shut-Off Classifications (in accordance with ANSI/FCI 70.2 and IEC 60534-4)

Valve Model	Characteristic	Port Diameter inch (mm)	Shut-Off Class	
			Standard	Class IV
392 & 392A	Equal Percentage / Modified Equal Percentage / Linear / Dyna-Flute / Dyna-Form / Low-Noise III	All	Standard	Class IV
			Optional	Class V
	Anti-Cavitation	All	Standard	Class V

Table 3

Globe Valve Approximate Weights lb (kg)

Valve Size (Inch)	Class	Body		
		Flanged	BWE	SWE
1	900 / 1500	93 (42)	85 (38)	85 (38)
2	900 / 1500	160 (73)	115 (52)	115 (52)

Angle Valve Approximate Weights lb (kg)

Valve Size	Class	Body		
		Flanged	BWE	SWE
1	900 / 1500	88 (40)	80 (36)	80 (36)
2	900 / 1500	153 (69)	110 (50)	110 (50)



Model 392 Control Valves

Technical Sales Bulletin

Table 4

Globe Valve - Port Diameters, Valve Plug Travel and Yoke Boss Diameter

Valve Size Inch	Characteristic	Port Diameter Inch (mm)	Max Valve Travel Inch (mm)	Stem Inch (mm)	Yoke Boss Diameter Inch (mm)
1	Equal Percentage with Dyna-Flute 1 Flute Plug	1/4 (6.4)	3/4 (19.1)	1/2 (12.7)	2-13/16 (71.4)
	Equal Percentage with Dyna-Flute 3 Flute Plug	1/4 (6.4)	3/4 (19.1)	1/2 (12.7)	2-13/16 (71.4)
		3/8 (9.5)			
		1/2 (12.7)			
	Equal Percentage with Dyna-Form Plug	1/4 (6.4)	3/4 (19.1)	1/2 (12.7)	2-13/16 (71.4)
		1/2 (12.7)			
		3/4 (19.1)	3/4 (19.1)	1/2 (12.7)	2-13/16 (71.4)
		1 (25.4)		3/4 (19.1)	3-9/16 (90.5)
	Modified Equal Percentage with Dyna-Form Plug	1/2 (12.7)	1-1/8 (28.6)	1/2 (12.7)	2-13/16 (71.4)
		3/4 (19.1)	1-1/8 (28.6)	3/4 (19.1)	3-9/16 (90.5)
		1 (25.4)	1-1/8 (28.6)	3/4 (19.1)	3-9/16 (90.5)
	Linear (Anti-Cavitation 2 Stage)	7/8 (22.2)	1-1/2 (38.1)	3/4 (19.1)	3-9/16 (90.5)
2	Equal Percentage	1-7/8 (47.6)	1-1/8 (28.6)	3/4 (19.1)	3-9/16 (90.5)
	Modified Equal Percentage	1-7/8 (47.6)	1-1/2 (38.1)	3/4 (19.1)	3-9/16 (90.5)
	Linear Linear Low-Noise III	1-7/8 (47.6)	1-1/2 (38.1)	3/4 (19.1)	3-9/16 (90.5)
	Equal Percentage with Dyna-Flute 1 Flute Plug	1/4 (6.4)	3/4 (19.1)	1/2 (12.7)	2-13/16 (71.4)
	Equal Percentage with Dyna-Flute 3 Flute Plug	1/4 (6.4)	3/4 (19.1)	1/2 (12.7)	2-13/16 (71.4)
		3/8 (9.5)			
		1/2 (12.7)			
	Equal Percentage with Dyna-Form Plug	1/4 (6.4)	3/4 (19.1)	1/2 (12.7)	2-13/16 (71.4)
		1/2 (12.7)		3/4 (19.1)	3-9/16 (90.5)
		3/4 (19.1)	3/4 (19.1)	3/4 (19.1)	3-9/16 (90.5)
		1 (25.4)	3/4 (19.1)	3/4 (19.1)	3-9/16 (90.5)
		1-1/4 (31.8)	3/4 (19.1)	3/4 (19.1)	3-9/16 (90.5)
		1-1/2 (38.1)	1-1/8 (28.6)	3/4 (19.1)	3-9/16 (90.5)
		1-1/2 (38.1)	1-1/8 (28.6)	3/4 (19.1)	3-9/16 (90.5)
	Modified Equal Percentage with Dyna-Form Plug	1/2 (12.7)	1-1/8 (28.6)	3/4 (19.1)	3-9/16 (90.5)
		3/4 (19.1)	1-1/8 (28.6)	3/4 (19.1)	3-9/16 (90.5)
		1 (25.4)	1-1/8 (28.6)	3/4 (19.1)	3-9/16 (90.5)
		1-1/4 (31.8)	1-1/8 (28.6)	3/4 (19.1)	3-9/16 (90.5)
1-1/2 (38.1)		1-1/2 (38.1)	3/4 (19.1)	3-9/16 (90.5)	
Linear (Anti-Cavitation 3 Stage)	1 (25.4)	2 (50.8)	3/4 (19.1)	3-9/16 (90.5)	

Model 392 Control Valves

Technical Sales Bulletin



Table 5

Angle Valve - Port Diameters, Valve Plug Travel and Yoke Boss Diameter

Valve Size Inch	Characteristic (Cage Style)	Flow	Port Diameter Inch (mm)	Max Valve Travel Inch (mm)	Stem Inch (mm)	Yoke Boss Diameter Inch (mm)
1	Linear (Anti-Cavitation 2 Stage)	Down	7/8 (22.2)	1-1/2 (38.1)	1/2 (12.7) 3/4 (19.1)	2-13/16 (71.4) 3-9/16 (90.5)
	Equal Percent	Down	3/4 (19.1)	1-1/8 (28.6)	3/4 (19.1)	3-9/16 (90.5)
	Equal Percent with Dyna-Flute Plug	Up	1/4 (6.4)	3/4 (19.1)	1/2 (12.7)	2-13/16 (71.4)
			3/8 (9.5)	3/4 (19.1)		
			1/2 (12.7)	3/4 (19.1)		
	Equal Percent with Dyna-Form Plug	Up	1/4 (6.4)	3/4 (19.1)	1/2 (12.7)	2-13/16 (71.4)
			1/2 (12.7)	3/4 (19.1)	1/2 (12.7)	2-13/16 (71.4)
			3/4 (19.1)	3/4 (19.1)	1/2 (12.7) 3/4 (19.1)	2-13/16 (71.4) 3-9/16 (90.5)
	Modified Equal Percent	Down	3/4 (19.1)	1-1/8 (28.6)	3/4 (19.1)	3-9/16 (90.5)
	Modified Equal Percent with Dyna-Form Plug	Up	1/2 (12.7)	1-1/8 (28.6)	1/2 (12.7)	2-13/16 (71.4)
3/4 (19.1)			1-1/8 (28.6)	1/2 (12.7) 3/4 (19.1)	2-13/16 (71.4) 3-9/16 (90.5)	
2	Linear (Standard) Linear (Low-Noise III)	Up	1-7/8 (47.6)	1-1/2 (38.1)	1/2 (12.7) 3/4 (19.1)	2-13/16 (71.4) 3-9/16 (90.5)
	Linear (Anti-Cavitation 3 Stage)	Down	1 (25.4)	2 (51.8)	3/4 (19.1)	3-9/16 (90.5)
	Equal Percent	Down	3/4 (19.1)	3/4 (19.1)	3/4 (19.1)	3-9/16 (90.5)
			1 (25.4)	3/4 (19.1)	3/4 (19.1)	3-9/16 (90.5)
			1-1/4 (31.8)	3/4 (19.1)	Consult Dyna-Flo	
			1-1/2 (38.1)	1-1/4 (31.8)	Consult Dyna-Flo	
	Equal Percent with Dyna-Flute Plug	Up	1/4 (6.4)	3/4 (19.1)	1/2 (12.7) 3/4 (19.1)	2-13/16 (71.4) 3-9/16 (90.5)
			3/8 (9.8)	3/4 (19.1)		
			1/2 (12.7)	3/4 (19.1)		
	Equal Percent with Dyna-Form Plug	Up	1/4 (6.4)	3/4 (19.1)	1/2 (12.7)	2-13/16 (71.4)
			1/2 (12.7)	3/4 (19.1)	1/2 (12.7)	2-13/16 (71.4)
			3/4 (19.1)	3/4 (19.1)	1/2 (12.7) 3/4 (19.1)	2-13/16 (71.4) 3-9/16 (90.5)
			1 (25.4)	3/4 (19.1)	1/2 (12.7) 3/4 (19.1)	2-13/16 (71.4) 3-9/16 (90.5)
	Modified Equal Percent	Down	3/4 (19.1)	1-1/8 (28.6)	3/4 (19.1)	3-9/16 (90.5)
			1 (25.4)	1-1/8 (28.6)	3/4 (19.1)	3-9/16 (90.5)
			1-1/4 (31.8)	1-1/8 (28.6)	Consult Dyna-Flo	
			1-1/2 (38.1)	1-1/2 (38.1)	Consult Dyna-Flo	
Modified Equal Percent with Dyna-Form Plug	Up	1-7/8 (47.6)	1-1/2 (38.1)	1/2 (12.7) 3/4 (19.1)	2-13/16 (71.4) 3-9/16 (90.5)	
		1 (25.4)	1-1/8 (28.6)	1/2 (12.7) 3/4 (19.1)	2-13/16 (71.4) 3-9/16 (90.5)	
		1-1/4 (31.8)	1-1/8 (28.6)			
Modified Equal Percent with Dyna-Form Plug	Up	1-1/2 (38.1)	1-1/2 (38.1)	1/2 (12.7) 3/4 (19.1)	2-13/16 (71.4) 3-9/16 (90.5)	



Model 392 Control Valves

Technical Sales Bulletin

Table 6

Standard Globe Valve Dimensions Inches (mm)

(Refer to Figure 2)

Valve Size (Inch)	ASME Class	Actuator Size	A	B	D		E
					DFC	DFO	
1 (1/2" Stem 2-13/16" YBD)	900 / 1500 RF	2105	11.50 (292)	2.06 (52)	40.50 (1029)	35.97 (914)	16.00 (406)
	900 / 1500 RTJ	2105	11.50 (292)	2.06 (52)	40.50 (1029)	35.97 (914)	16.00 (406)
	1500 BWE	2105	11.50 (292)	2.06 (52)	40.50 (1029)	35.97 (914)	16.00 (406)
	1500 SWE	2105	11.50 (292)	2.06 (52)	40.50 (1029)	35.97 (914)	16.00 (406)
2 (1/2" Stem 2-13/16" YBD)	900 / 1500 RF	2105	14.75 (375)	3.06 (78)	40.56 (1030)	36.03 (915)	16.00 (406)
	900 / 1500 RTJ	2105	14.88 (378)	3.06 (78)	40.56 (1030)	36.03 (915)	16.00 (406)
	1500 BWE	2105	14.75 (375)	3.06 (78)	40.56 (1030)	36.03 (915)	16.00 (406)
	1500 SWE	2105	14.75 (375)	3.06 (78)	40.56 (1030)	36.03 (915)	16.00 (406)
NOTES:	D dimensions will vary depending on valve stem diameter and characteristics, refer to Tables 8 to 11.						
	RF = Raised Face / RTJ = Ring Type Joint / BWE = Butt Weld / SWE = Socket Weld						

Table 7

Standard Angle Valve Dimensions Inches (mm)

(Refer to Figure 2)

Valve Size (Inch)	ASME Class	Actuator Size	A	D		E
				DFC	DFO	
1 (1/2" Stem 2-13/16" YBD)	900 RF	2105	5.56 (141)	39.31 (988)	34.78 (883)	16.00 (406)
	900 RTJ	2105	5.56 (141)	39.31 (988)	34.78 (883)	16.00 (406)
	1500 RF	2105	5.56 (141)	39.31 (988)	34.78 (883)	16.00 (406)
	1500 RTJ	2105	5.56 (141)	39.31 (988)	34.78 (883)	16.00 (406)
	1500 BWE	2105	5.56 (141)	39.31 (988)	34.78 (883)	16.00 (406)
	1500 SWE	2105	5.56 (141)	39.31 (988)	34.78 (883)	16.00 (406)
2 (1/2" Stem 2-13/16" YBD)	900 RF	2105	7.00 (178)	39.19 (955)	34.66 (880)	16.00 (406)
	900 RTJ	2105	7.06 (179)	39.19 (955)	34.66 (880)	16.00 (406)
	1500 RF	2105	7.00 (178)	39.19 (955)	34.66 (880)	16.00 (406)
	1500 RTJ	2105	7.06 (179)	39.19 (955)	34.66 (880)	16.00 (406)
	1500 BWE	2105	7.00 (178)	39.19 (955)	34.66 (880)	16.00 (406)
	1500 SWE	2105	7.00 (178)	39.19 (955)	34.66 (880)	16.00 (406)
NOTES:	D dimensions will vary depending on valve stem diameter and characteristics, refer to Tables 8 to 11.					
	RF = Raised Face / RTJ = Ring Type Joint / BWE = Butt Weld / SWE = Socket Weld					

Model 392 Control Valves

Technical Sales Bulletin



Table 8

Dimension C for Globe Valves with Standard Bonnets

Inch (mm) (Refer to Figure 2)

Valve Size (Inch)	Dimension C		
	ASME Class	2-13/16 (71) Yoke Boss Diameter	3-9/16 (90) Yoke Boss Diameter
1	900 / 1500	10.25 (260)	10.50 (267)
2	900 / 1500	10.31 (261)	10.56 (267)
2 Anti-Cavitation 2 Stage	900 / 1500	11.00 (279)	11.25 (286)

Table 9

Dimension C for Globe Valves with Style 1 Extension Bonnets

Inch (mm) (Refer to Figure 2)

Valve Size (Inch)	Dimension C		
	ASME Class	2-13/16 (71) Yoke Boss Diameter	3-9/16 (90) Yoke Boss Diameter
1	900 / 1500	15.12 (384)	15.75 (400)
2	900 / 1500	16.94 (430)	17.56 (446)
2 Anti-Cavitation 2 Stage	900 / 1500	17.62 (448)	18.25 (464)

Table 10

Dimension C for Angle Valves with Standard Bonnets

Inch (mm) (Refer to Figure 2)

Valve Size (Inch)	Dimension C		
	ASME Class	2-13/16 (71) Yoke Boss Diameter	3-9/16 (90) Yoke Boss Diameter
1	900 / 1500	9.06 (230)	9.38 (238)
2	900 / 1500	8.94 (277)	9.19 (233)
2 Anti-Cavitation 2 Stage	900 / 1500	9.62 (244)	9.88 (251)

Table 11

Dimension C for Angle Valves with Style 1 Extension Bonnets

Inch (mm) (Refer to Figure 2)

Valve Size (Inch)	Dimension C		
	ASME Class	2-13/16 (71) Yoke Boss Diameter	3-9/16 (90) Yoke Boss Diameter
1	900 / 1500	13.94 (354)	14.67 (373)
2	900 / 1500	15.56 (395)	16.19 (411)
2 Anti-Cavitation 2 Stage	900 / 1500	16.25 (413)	16.88 (429)



Model 392 Control Valves

Technical Sales Bulletin

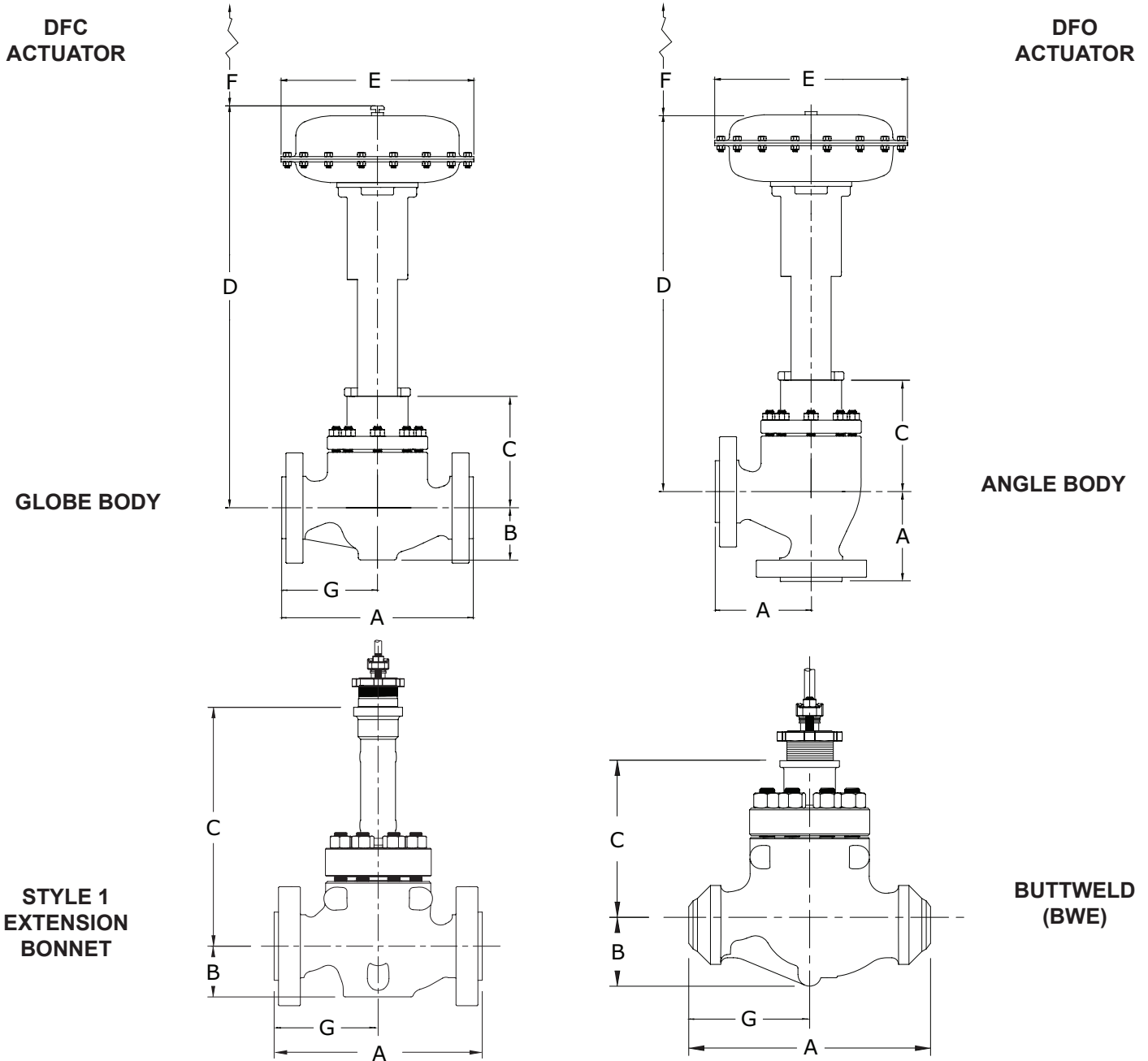

F Dimension

1" & 2" Valve - 6.88" (175 mm)

Figure 2 Typical Valve Assembly Diagrams

Model 392 Control Valves

Technical Sales Bulletin

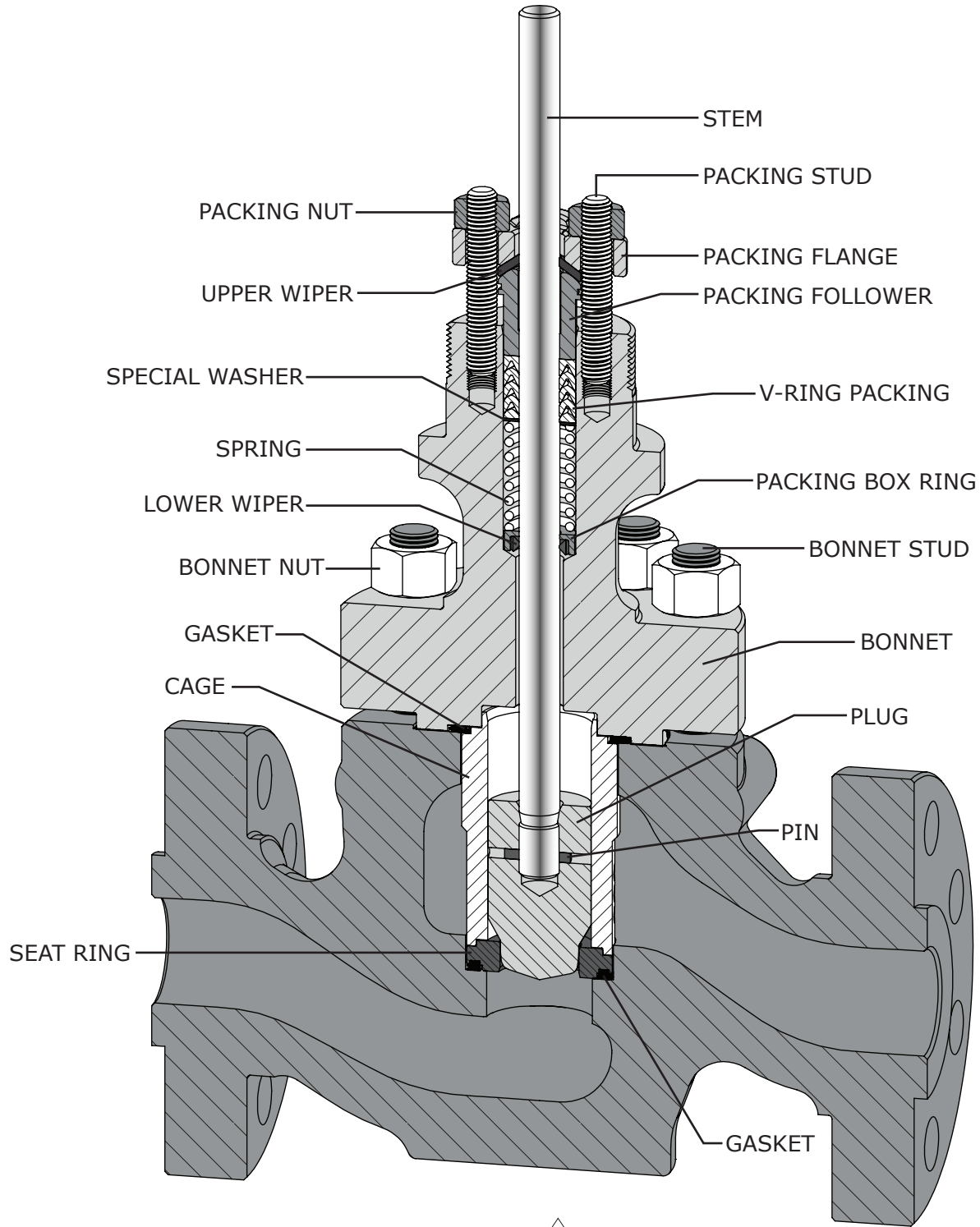

Figure 3 Cross-section of 392 Control Valve with Dyna-Form Trim

Model 392 Control Valves

Technical Sales Bulletin

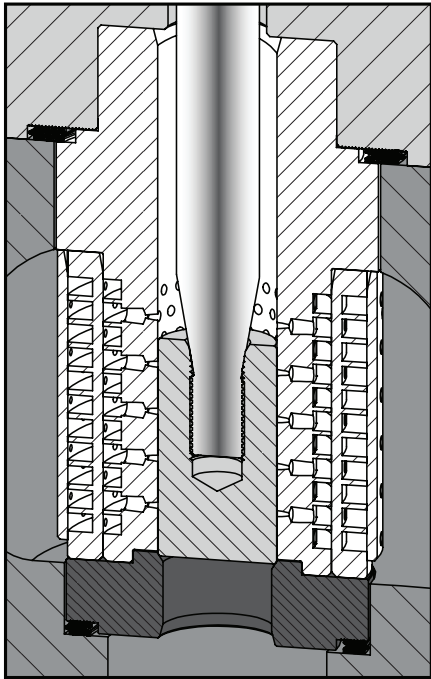

Figure 4 *Anti-Cavitation Trim Detail*

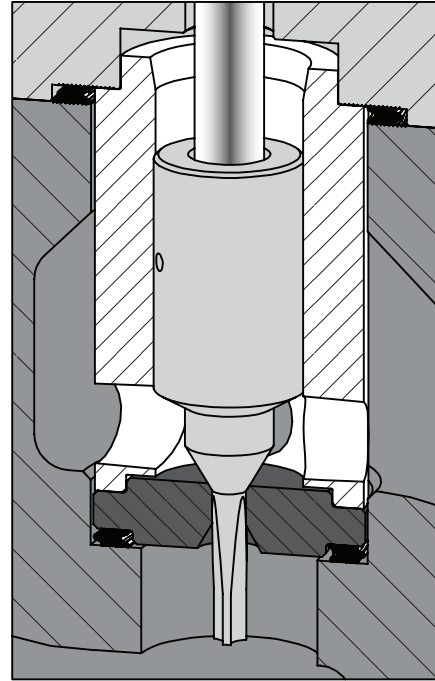

Figure 5 *Dyna-Flute Trim Detail*

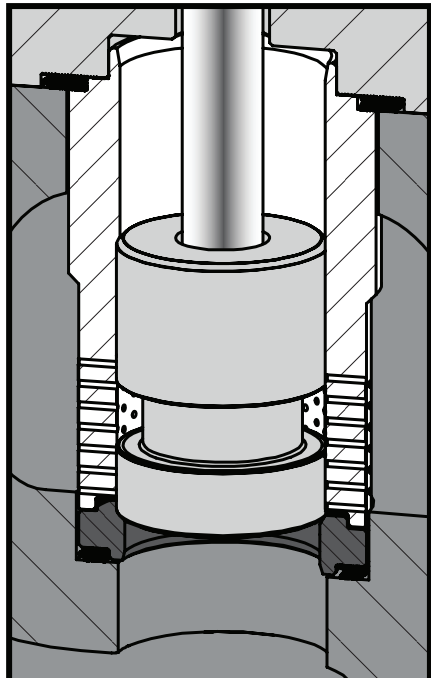

Figure 6 *Low-Noise Trim Detail*

Model 392 Control Valves

Technical Sales Bulletin

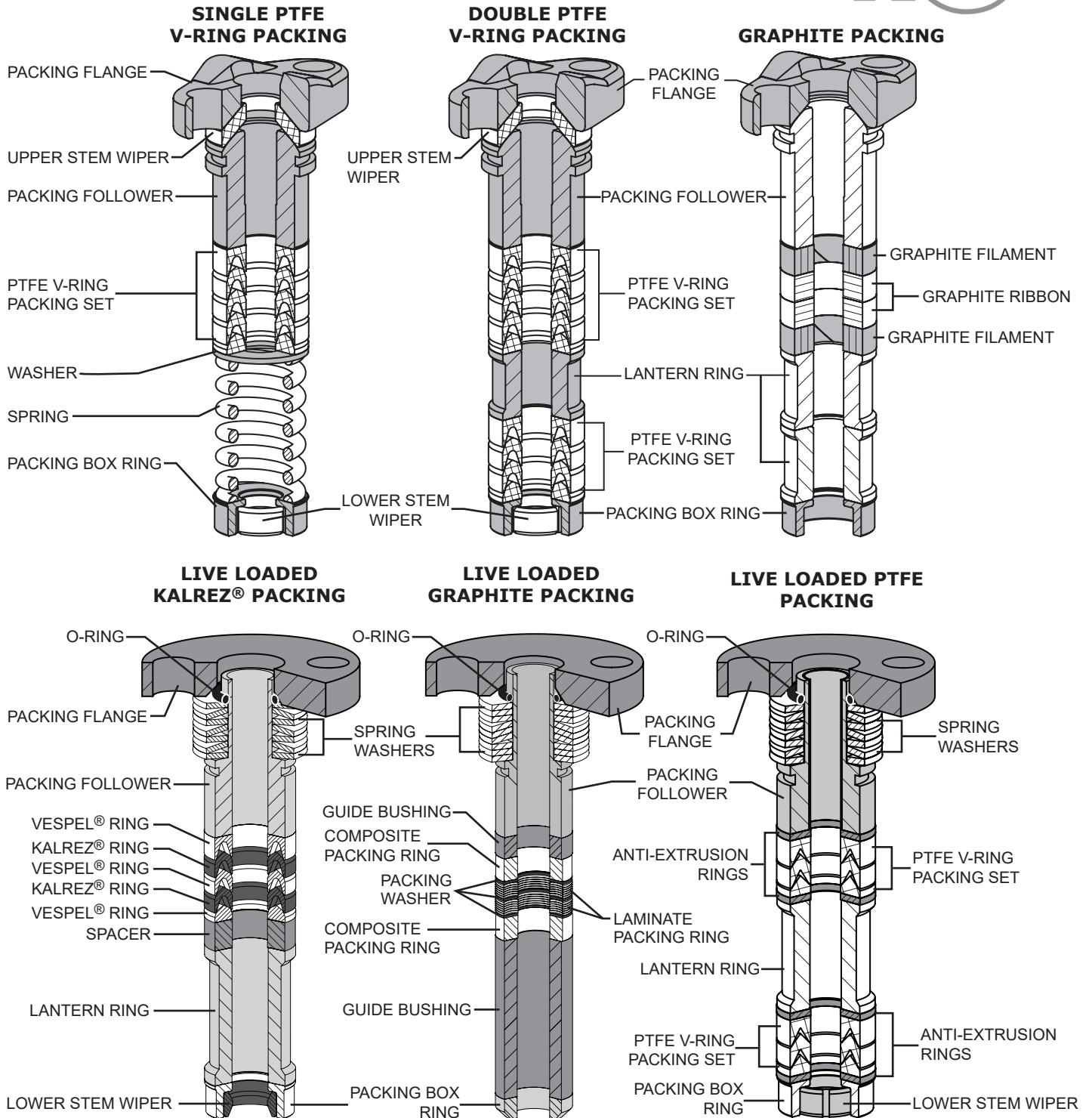

Figure 7 Typical Packing Arrangements



Model 392 Control Valves

Technical Sales Bulletin

Table 12

Common Valve Parts Typical Construction Materials and Temperature Limitations

Part	Material	Temperature Limitations			
		Min. °F	Max. °F	Min. °C	Max. °C
Valve Stem	S20910	NLF ⁽¹⁾	NLF ⁽¹⁾	NLF ⁽¹⁾	NLF ⁽¹⁾
Spiral Wound Gaskets	S30400 / Graphite	NLF ⁽¹⁾	NLF ⁽¹⁾	NLF ⁽¹⁾	NLF ⁽¹⁾
Packing	PTFE V-Ring	-50	450	-46	232
	Graphite (Ribbon/Filament)	NLF ⁽¹⁾	1000 ⁽²⁾	NLF ⁽¹⁾	537 ⁽²⁾

NOTES:

- 1** - NLF - This Material is Not A Limiting Factor. For the temperature limitation refer to the valve body material temperature limit.
- 2** - Oxidizing service limited to 700°F (371°C)

Table 13

Body to Bonnet Bolting Temperature Limitations

Body Material	ASME Class	Bolt/Nut Material	Temperature Limitations			
			Min. °F	Max. °F	Min. °C	Max. °C
LCC	150/300/600	B7/2H ⁽¹⁾⁽²⁾	-50	650	-46	343
		B7M/2HM ⁽³⁾	-50	650	-46	343
WCC/WC9	150/300/600	B7/2H ⁽¹⁾⁽²⁾	-20	800	-29	427
		B7M/2HM ⁽³⁾	-20	800	-29	427
CF8M	150/300/600	B7 Fluorokote #1 / 2H Fluorokote #1 (Standard) ⁽²⁾	-50	500	-46	260
		B8M/8M ⁽²⁾	-325	800	-198	427
		B7M Fluorokote #1/ 2HM Fluorokote #1 ⁽³⁾	-50	500	-46	260

NOTES:

- 1** - Standard non-NACE option.
- 2** - NACE MR0175/ISO15156 Non-Exposed Bolting option (Bolting that is not directly exposed to sour environments and is not to be buried, insulated, equipped with flange protectors, or otherwise denied direct atmospheric exposure).
- 3** - NACE MR0175/ISO15156 Exposed Bolting option (Bolting that will be exposed directly to the sour environment or that will be buried, insulated, equipped with flange protectors, or otherwise denied direct atmospheric exposure).

Model 392 Control Valves

Technical Sales Bulletin



Table 14

Common Trim Options and Temperature Ratings

Trim Number	Valve Plug	Stem	Cage	Seat Ring	Minimum ⁽¹⁾ Temperature	Maximum ⁽¹⁾ Temperature
					°F (°C)	°F (°C)
S	S41600 HT	S20910	S17400 PH	S41600 HT	-20 (-29)	650 (343) ⁽⁵⁾
N ⁽⁴⁾	S31600 ⁽²⁾ / ALLOY 6 Seat and Guide	S20910	S17400 DH1150	S31600 ⁽²⁾ / ALLOY 6 Seat	-50 (-46)	650 (343)
C	S31600 ⁽²⁾ / ALLOY 6 Seat and Guide	S20910	S31600 ⁽²⁾ ENC ⁽³⁾	S31600 ⁽²⁾ / ALLOY 6 Seat	-50 (-46)	650 (343)
A	S44004 HT	S20910	S17400 H900	S44004 HT	-20 (-29)	650 (343) ⁽⁵⁾
J ⁽⁴⁾	S31600 ⁽²⁾ / ALLOY 6 Seat, Guide, & Contour	S20910	S17400 DH1150	S31600 ⁽²⁾ / ALLOY 6 Seat and Bore	-50 (-46)	800 (427)

- 1 Check body material temperature limitations.
- 2 All S31600 barstock is dual grade S31600/S31603 (316/316L).
- 3 - ENC =Electroless Nickel Coating.
- 4 - Metal trim parts compatible with NACE MR0175/ISO 15156. Environmental restrictions may apply.
- 5 - Temperature limitations can be extended to 800°F (427°C) for 1 and 2 inch valves.



Model 392 Control Valves

Technical Sales Bulletin

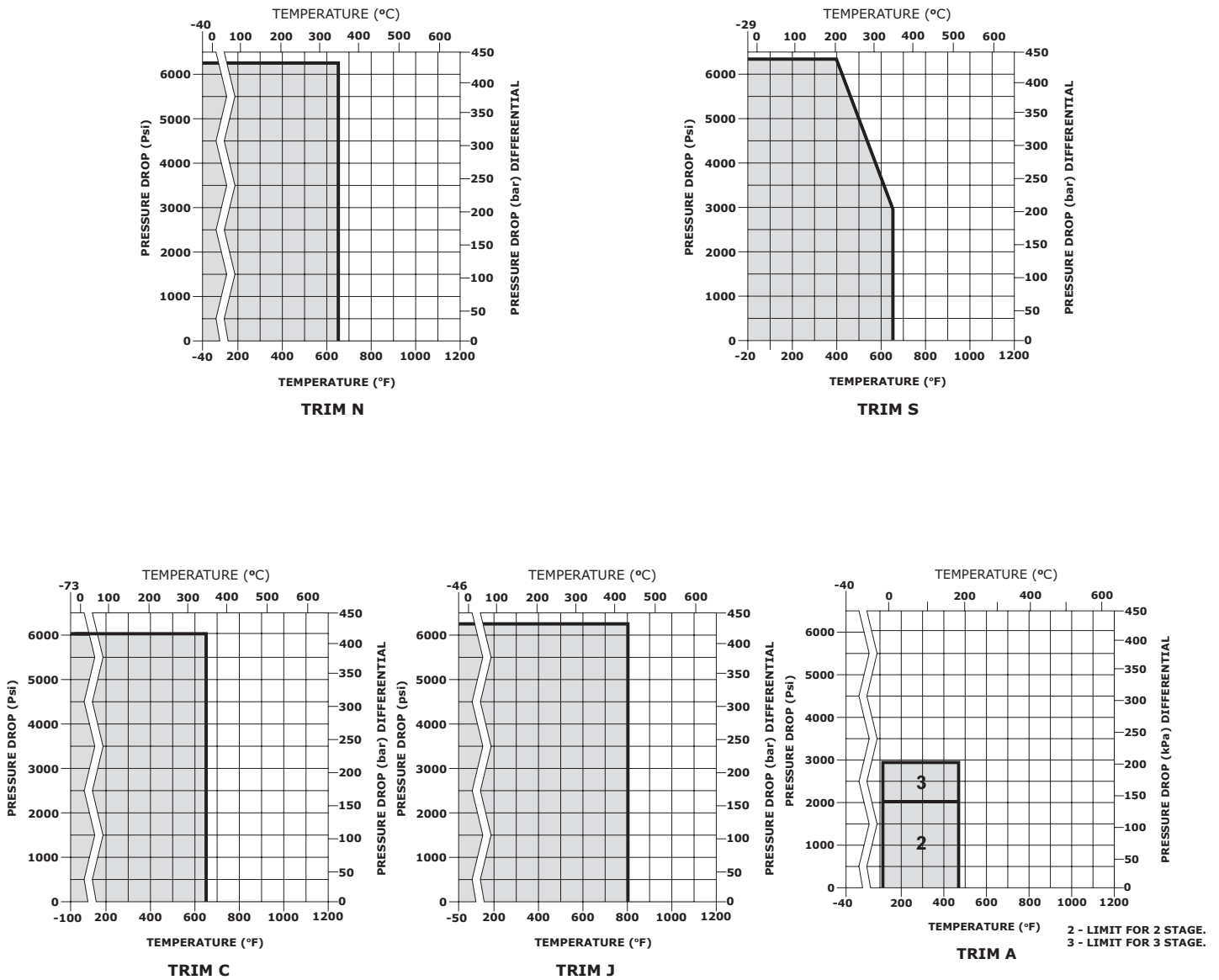

Figure 8 Trim Material Pressure / Temperature Limitations

Model 392 Control Valves

Technical Sales Bulletin



Table 15

Maximum Sizing Coefficients
Equal Percentage Characteristic
Globe Body Valve
Flow Up

Valve Size Inch	Port Inch (mm)	Travel Inch (mm)	Coefficient	Percentage of Valve Travel
				100%
1	1/4 (6.4)	3/4 (19.1)	C _v	1.61
	1/2 (12.7)	3/4 (19.1)	C _v	5.39
	1/2 (12.7)	1-1/8 (28.6)	C _v	6.50
	3/4 (19.1)	3/4 (19.1)	C _v	9.61
	3/4 (19.1)	1-1/8 (28.6)	C _v	12.5
	1 (25.4)	3/4 (19.1)	C _v	13.0
	1 (25.4)	1-1/8 (28.6)	C _v	17.1
2	1/4 (6.4)	3/4 (19.1)	C _v	1.61
	1/2 (12.7)	3/4 (19.1)	C _v	5.39
	1/2 (12.7)	1-1/8 (28.6)	C _v	6.50
	3/4 (19.1)	3/4 (19.1)	C _v	11.9
	3/4 (19.1)	1-1/8 (28.6)	C _v	12.5
	1 (25.4)	3/4 (19.1)	C _v	19.7
	1 (25.4)	1-1/8 (28.6)	C _v	24.2
	1-1/4 (31.8)	3/4 (19.1)	C _v	26.7
	1-1/4 (31.8)	1-1/8 (28.6)	C _v	33.0
	1-1/2 (38.1)	1-1/8 (28.6)	C _v	46.3
	1-1/2 (38.1)	1-1/2 (38.1)	C _v	52.5
	1-7/8 (47.6)	1-1/8 (28.6)	C _v	45.8
	1-7/8 (47.6)	1-1/2 (38.1)	C _v	54.4

NOTE: For full list of sizing coefficients refer to document P-CVSM.

Table 16

Maximum Sizing Coefficients
Equal Percentage Characteristic
Angle Body Valve
Flow Down

Valve Size Inch	Port Inch (mm)	Travel Inch (mm)	Coefficient	Percentage of Valve Travel
				100%
2	3/4 (19.1)	3/4 (19.1)	C _v	5.58

NOTE: For more information on angle body sizing coefficients contact Dyna-Flo.

Our Commitment to Quality

Curtiss-Wright Flow Control Company Canada is committed to continuous improvement. While all efforts have been made to ensure the accuracy of the content in this document, modifications or improvements to the information, specifications, and designs may occur at any time without notice. This document was published for informational purposes only, and does not express or imply suitability, a warranty, or guarantee regarding the products or services described herein or their use or applicability.

Neither Curtiss-Wright Flow Control Company, nor any of their affiliated entities assumes responsibility for the selection, use and maintenance of any product. Responsibility for selection, use and maintenance of any product remains with the purchaser and end-user.



Model 392 Control Valves

MODEL NUMBERING SYSTEM

SAMPLE PART NUMBER: 392-2CFL-S02P2-ES4

BODY STYLE						-		
-	GLOBE	A	ANGLE					
VALVE SIZE						2		
1	1 INCH	2	2 INCH					
ASME RATING						C		
C	900/1500							
END CONNECTION						F		
F	RF	J	RTJ	L	BWE SCH 80		U	BWE SCH 120
P	BWE SCH 160	S	SWE					
BODY MATERIAL						L		
L	LCC	W	WCC	M	CF8M		9	WC9
BOLTING						-		
-	B7 / 2H	A	B7M / 2HM	B	B8M / 8M			
K	B7 / 2H FLUOROKOTE #1			L	B7M / 2HM FLUOROKOTE #1			
TRIM						S		
S	TRIM S	C	TRIM C	N	TRIM N		A	TRIM A
J	TRIM J							
PORT SIZE						02		
01	3/16" PORT	02	1/4" PORT	03	3/8" PORT		04	1/2" PORT
05	5/8" PORT	06	3/4" PORT	07	7/8" PORT		08	1" PORT
10	1-1/4" PORT	12	1-1/2" PORT	15	1-7/8" PORT			
PACKING STYLE						P		
P	SINGLE PTFE V-RING (PRESSURE)			J	DOUBLE PTFE V-RING (PRESSURE)			
G	SINGLE GRAPHITE (PRESSURE)			V	DOUBLE PTFE V-RING (VACUUM)			
R	DOUBLE PTFE V-RING (VACUUM / PRESSURE)			L	LIVE LOADED PTFE V-RING (PRESSURE)			
T	LIVE LOADED GRAPHITE (PRESSURE)			D	LIVE LOADED DUPLEX (PRESSURE)			
K	LIVE LOADED KALREZ® (PRESSURE)			F	LIVE LOADED KALREZ® FIRE SAFE (PRESSURE)			
YOKE BOSS SIZE						2		
2	2-13/16" (1/2" STEM)	3	3-9/16" (3/4" STEM)					
PAINT						-		
-	DFPS-01 (STANDARD)			2	DFPS-02 (SEVERE SERVICE)			
3	DFPS-03 (HIGH TEMPERATURE)							
CHARACTERISTIC						E		
E	EQUAL PERCENT			M	MODIFIED EQUAL PERCENT			
L	LINEAR			2	ANTI-CAVITATION 2 STAGE (LINEAR)			
3	ANTI-CAVITATION 3 STAGE (LINEAR)			F	DYNA-FORM (EQUAL PERCENT)			
T	DYNA-FORM (MODIFIED EQUAL PERCENT)			Y	DYNA-FLUTE 1 (EQUAL PERCENT)			
Z	DYNA-FLUTE 3 (EQUAL PERCENT)			H	LOW-NOISE III A1 (LINEAR)			
B	LOW-NOISE III B1 (LINEAR)			P	LOW-NOISE III B3 (LINEAR)			
I	LOW-NOISE III C3 (LINEAR)			D	LOW-NOISE III D3 (LINEAR)			
BONNET STYLE							S	
S	STANDARD	T	STANDARD TAPPED	E	EXTENSION STYLE 1			
SHUT-OFF CLASS						4		
4	CLASS IV	5	CLASS V					

392