

# Model 350/351 Control Valves

## Technical Sales Bulletin



**Figure 1** Model 350 Control Valve and DFC Actuator

Model 350 Series control valves (Figure 1) are heavy-duty globe style valves featuring expanded end connections and large internal cavities. Designed to keep valve outlet velocities within practical limits, these high-capacity valves are well suited for service applications where oversized piping is used to limit flow velocities.

350 Series control valves are cage guided, single port valves that can be used for both throttling or on-off process control, and function especially well for noise reduction requirements. The standard actuator for 350 Series valves are Dyna-Flo Model DFC or DFO linear actuators (spring return diaphragm style), Model DFLP pneumatic piston actuators are also available.

Model 350 Series control valves are manufactured to a high level of quality specifications to ensure superior performance and customer satisfaction.

### Features

#### Sour Service Capability

Available in standard configurations that comply with NACE MR0175/ISO 15156.

#### Versatility

A wide range of trim options including Low Noise and Anti-Cavitation make the 350 one of our most versatile control valves. Trims are also interchangeable between full-sized and restricted-capacity to better match variable flow demands.

#### Piping Efficiency

The expanded end connections of the 350 Series control valves can eliminate the need for line swages and accommodate oversized pipe arrangements.

#### Noise Reduction Capabilities

350 Series control valves offer a large selection of Low-Noise trim options that can reduce noise between 18 dbA and 40 dbA depending on configurations.

#### Field Service Friendly

No special tools are required to change or inspect trim. Top access makes in-line service easy.

#### Pressure Drop Capabilities

Model 350 control valves can shut off against inlet pressures equal to the ASME B16.34 rating.

#### Industrial High Quality External Coatings

Our standard industrial high quality external coatings provide long lasting resistance to the harshest environments.

#### Emissions Reducing Packing

Help prevent the loss of process media and reduce packing maintenance with the use of Dyna-Flo's Live Loaded PTFE, graphite, and KALREZ® packing systems.



# Model 350/351 Control Valves

## Technical Sales Bulletin

### SPECIFICATIONS

#### Configurations

The Model 350/351 control valve is a high capacity single port, globe style valve, with a bolted type bonnet. The standard valve plug action is push down to close.

PTFE Seat and Metal Seat Available.

Consult your Dyna-Flo sales office for other available configurations.

#### Sizes and Connection Styles

Models:	350 & 351
Size:	8x6", 10x8", 12x6", and 12x8"
Body:	Globe
Rating:	ASME 150 / 300 / 600
Connections:	RF / RTJ / BWE - Refer to Tables 1, 2, and 6 for available configurations.

#### Maximum Inlet Temperature and Pressures

Flanged valves consistent with ASME Class rating as per ASME B16.34, unless limited as follows:

**Temperature Limits:** Tables 15, 16, and 17.

**Standard Valve Trim:** Figures 10 and 11.

**Anti-Cavitation Trim:** Figure 12.

#### Maximum Pressure Drops

Maximum pressure drop is the same as maximum inlet pressure unless restricted by the following:

**Standard Valve Trim:** Figures 10 and 11.

**Low-Noise Valve Trim:** Figure 12.

#### Characteristic and Flow Direction

- Equal Percentage (Standard) - Flow Down
- Quick Opening - Flow Down
- Linear - Flow Down
- Low-Noise (Linear) - Flow Up
- Anti-Cavitation 1-Stage (Linear) - Flow Down
- Anti-Cavitation 2-Stage (Linear) - Flow Down

#### Dimensions

##### Valve Outline Dimension Diagram

Refer to Figure 2.

##### Valve Dimensions

Refer to Tables 7 to 9.

#### Approximate Valve Body Weights

Refer to Table 6.

#### Materials

Body and bonnet material options include:

LCC (A350-LF2 optional\* bonnet material)

WCC (A350-LF2 optional\* bonnet material)

WC9 (A182-F22 optional\* bonnet material)

CF8M (A182-F316 optional\* bonnet material)

**\*NOTE:** Dyna-Flo reserves the right to substitute a cast material with the forged bar equivalent in the event a casting is not available.

Refer to Tables 15-17 for valve construction material temperature limitations.

Refer to Tables 11 & 12 for trim selections.

Consult Factory for other material options.

#### Cross-Section of the Model 350 Series Control Valves

Refer to Figures 3 to 9.

#### Port Diameters and Maximum Valve Plug Travel

Refer to Tables 3 to 5.

#### Packing Type

The Standard packing is PTFE V-ring. Live-loaded low emission, graphite, KALREZ<sup>®</sup>, and other packing arrangements are available. Refer to Figure 9.

#### Maximum Valve Sizing Coefficients

For full list of coefficients refer to document P-CVSM.

#### Service Application

Refer to Tables 11, 12, & 14.

For more information and other options contact your Dyna-Flo sales office.

# Model 350/351 Control Valves

## Technical Sales Bulletin



**Table 1**

### Available Valve Configurations and Shut-Off Class

Valve Model	Valve Size Inch	ASME Class	Valve Seat	Shut-Off Class (in accordance with ANSI / FCI 70.2)
350	8x6, 10x8, 12x6, 12x8	150 / 300 / 600	Metal	IV (Standard)
				V <sup>(1)</sup> (Optional)
			PTFE	V (Optional)
350 with Anti-Cavitation 1-Stage	8x6, 10x8, 12x6, 12x8	600	Metal	IV (Standard)
				V (Optional)
350 with Anti-Cavitation 2-Stage	8x6, 12x6, 12x8	600	Metal or PTFE	V
351	8x6, 10x8, 12x6, 12x8	150 / 300 / 600	Metal	II (Standard)
				III (Optional)
				IV <sup>(2)</sup> (Optional)
<b>Notes:</b>	<b>1</b> - Class V shut-off requires spring-loaded seal ring, radius-seat plug, and wide-bevel seat ring. Not available for 8 inch port quick opening trim. Not available with S31600 plug and seat ring.			
	<b>2</b> - Class IV shut-off requires multiple graphite piston rings.			

**Table 2**

### Available Valve Configurations for Class VI Shut-Off (in accordance with ANSI / FCI 70.2)

Valve Model	Port Size Inch	Valve Seat	Minimum Seat Load
350	≥3.4375≤7	Metal	300 lbs./lineal inch
	≥3.4375≤7	PTFE	Consult Dyna-Flo

**Note:** Class VI shut-off requires special seal materials. Refer to Table 12 for Class VI trim materials.



# Model 350/351 Control Valves

## Technical Sales Bulletin

**Table 3**

**Valve Size, Port Diameters, Plug Travel, Stem / Yoke Boss Diameters, and Characteristic for Standard Valves**

Valve Size	Port Diameter		Max Valve Plug Travel		Standard Yoke Boss Diameter (YBD)				Characteristic
	Inch	Inch	mm	Inch	mm	Stem Diameter		YBD	
						Inch	mm	Inch	mm
8x6 12x6	7	177.8	2	50.8	3/4 <sup>(1)</sup>	19.1 <sup>(1)</sup>	3-9/16 <sup>(1)</sup>	90.5 <sup>(1)</sup>	Equal Percentage Quick Opening Linear
					1	25.4	5	127	
					1-1/4	31.8	5H	127H	
10x8	8	203.2	3	76.2	3/4 <sup>(1)</sup>	19.1 <sup>(1)</sup>	3-9/16 <sup>(1)</sup>	90.5 <sup>(1)</sup>	Equal Percentage Quick Opening Linear
					1	25.4	5	127	
					1-1/4	31.8	5H	127H	
12x8 <sup>(2)</sup> (Class 300 & 600)	8	203.2	3	76.2	3/4 <sup>(1)</sup>	19.1 <sup>(1)</sup>	3-9/16 <sup>(1)</sup>	90.5 <sup>(1)</sup>	Equal Percentage Quick Opening Linear
					1	25.4	5	127	
					1-1/4	31.8	5H	127H	
<b>Notes:</b>	1 - Standard option.								
	2 - Bonnet spacer required.								

# Model 350/351 Control Valves

## Technical Sales Bulletin



Table 4

Valve Size, Port Diameters, Plug Travel, Stem / Yoke Boss Diameters for Low-Noise Valves

Valve Size	Port Diameter		Max Valve Plug Travel		Standard Yoke Boss Diameter (YBD)				Characteristic
	Inch	mm	Inch	mm	Stem Diameter		YBD		
	Inch	mm	Inch	mm	Inch	mm	Inch	mm	
8x6	7	177.8	3	76.2	3/4 <sup>(1)</sup>	19.1 <sup>(1)</sup>	3-9/16 <sup>(1)</sup>	90.5 <sup>(1)</sup>	Low-Noise
					1	25.4	5	127	
					1-1/4	31.8	5H	127H	
			4	101.6	3/4 <sup>(1)</sup>	19.1 <sup>(1)</sup>	3-9/16 <sup>(1)</sup>	90.5 <sup>(1)</sup>	
					1	25.4	5	127	
					1-1/4	31.8	5H	127H	
	5-3/8 <sup>(2)</sup>	136.5 <sup>(2)</sup>	5 <sup>(2)</sup>	127.0 <sup>(2)</sup>	3/4 <sup>(1)</sup>	19.1 <sup>(1)</sup>	3-9/16 <sup>(1)</sup>	90.5 <sup>(1)</sup>	
					1	25.4	5	127	
					1-1/4	31.8	5H	127H	
12x6 <sup>(2)</sup>	5-3/8	136.5	6-1/2	165.1	3/4 <sup>(1)</sup>	19.1 <sup>(1)</sup>	3-9/16 <sup>(1)</sup>	90.5 <sup>(1)</sup>	Low-Noise
					1	25.4	5	127	
					1-1/4	31.8	5H	127H	
10x8	8	203.2	6	152.4	3/4 <sup>(1)</sup>	19.1 <sup>(1)</sup>	3-9/16 <sup>(1)</sup>	90.5 <sup>(1)</sup>	Low-Noise
					1	25.4	5	127	
					1-1/4	31.8	5	127	
	7	177.8	6	152.4	3/4 <sup>(1)</sup>	19.1 <sup>(1)</sup>	3-9/16 <sup>(1)</sup>	90.5 <sup>(1)</sup>	
					1	25.4	5	127	
					1-1/4	31.8	5H	127H	
12x8 <sup>(2)</sup> (Class 300 & 600)	8	203.2	6	152.4	3/4 <sup>(1)</sup>	19.1 <sup>(1)</sup>	3-9/16 <sup>(1)</sup>	90.5 <sup>(1)</sup>	Low-Noise
	7	177.8			1	25.4	5	127	
					1-1/4	31.8	5H	127H	
<b>Notes:</b>	<b>1</b> - Standard option.								
	<b>2</b> - Bonnet spacer required.								



# Model 350/351 Control Valves

## Technical Sales Bulletin

**Table 5**

**Valve Size, Port Diameters, Plug Travel, Stem / Yoke Boss Diameters For Anti-Cavitation**

Valve Size	Port Diameter		Max Valve Plug Travel		Standard Yoke Boss Diameter (YBD)				Characteristic
	Inch	mm	Inch	mm	Stem Diameter		YBD		
					Inch	mm	Inch	mm	
8x6	5-3/8	136.5	5	127.0	3/4 <sup>(1)</sup>	19.1 <sup>(1)</sup>	3-9/16 <sup>(1)</sup>	90.5 <sup>(1)</sup>	Anti-Cavitation 2-Stage
					1	25.4	5	127	
					1-1/4	31.8	5	127	
8x6 / 12x6	7	177.8	2	50.8	1 <sup>(1)</sup>	25.4 <sup>(1)</sup>	5 <sup>(1)</sup>	127 <sup>(1)</sup>	Anti-Cavitation 1-Stage
					1-1/4	31.8	5	127	
			2-1/4	57.2	1 <sup>(1)</sup>	25.4 <sup>(1)</sup>	5 <sup>(1)</sup>	127 <sup>(1)</sup>	Anti-Cavitation 1-Stage Extended Travel
					1-1/4	31.8	5	127	
12 x 6	5-3/8	136.5	6	152.4	3/4 <sup>(1)</sup>	19.1 <sup>(1)</sup>	3-9/16 <sup>(1)</sup>	90.5 <sup>(1)</sup>	Anti-Cavitation 2-Stage
					1	25.4	5	127	
					1-1/4	31.8	5	127	
10x8 / 12x8	8	203.2	3	76.2	1 <sup>(1)</sup>	25.4 <sup>(1)</sup>	5 <sup>(1)</sup>	127 <sup>(1)</sup>	Anti-Cavitation 1-Stage
					1-1/4	31.8	5	127	
			3-3/8	85.7	1 <sup>(1)</sup>	25.4 <sup>(1)</sup>	5 <sup>(1)</sup>	127 <sup>(1)</sup>	Anti-Cavitation 1-Stage Extended Travel
					1-1/4	31.8	5	127	
12x8	7	177.8	6	152.4	3/4 <sup>(1)</sup>	19.1 <sup>(1)</sup>	3-9/16 <sup>(1)</sup>	90.5 <sup>(1)</sup>	Anti-Cavitation 2-Stage
					1	25.4	5	127	
					1-1/4	31.8	5	127	

**Notes:** 1 - Standard Option.

# Model 350/351 Control Valves

## Technical Sales Bulletin



**Table 6**

### Approximate Valve Body Weights

Valve Size (inch)	Connection	ASME Class			
		150 / 300		600	
		lb	Kg	lb	Kg
8x6	Flanged	625	284	680	308
	Buttweld	-	-	600	272
10x8	Flanged	1,250	567	1,640	744
	Buttweld	-	-	1,130	512
12x6	Flanged	1,102	500	1,590	721
	Buttweld	-	-	1,160	526
12x8	Flanged	1,440	653	1,890	857
	Buttweld	-	-	1,450	658



# Model 350/351 Control Valves

## Technical Sales Bulletin

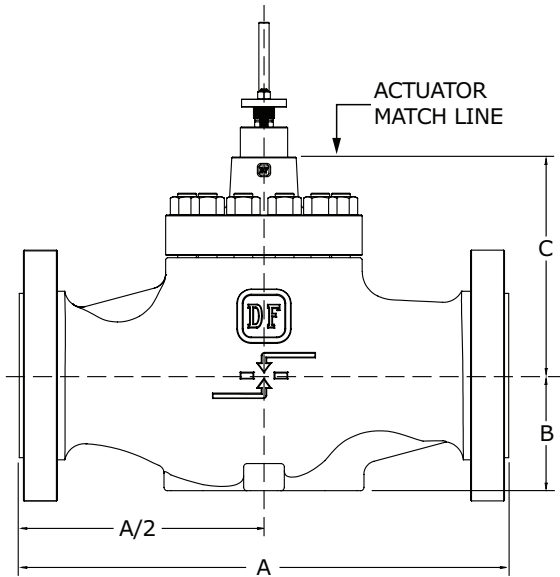

**FLANGED VALVE ASSEMBLY  
SIZES 8x6" THROUGH 12x6"**

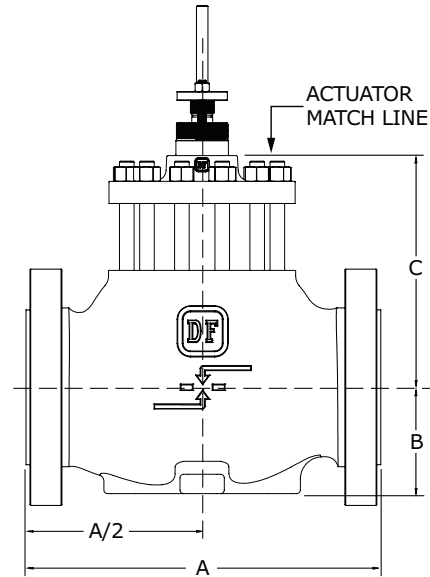

**FLANGED VALVE ASSEMBLY FOR LOW-NOISE TRIM  
SIZES 8x6" THROUGH 12x6"**

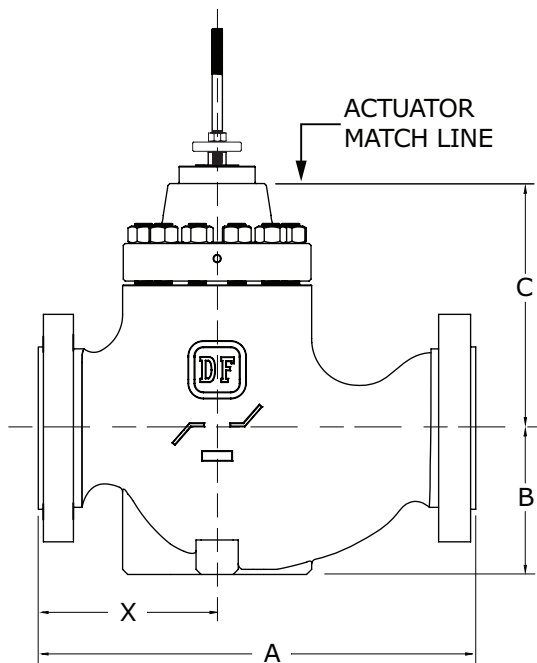

**12X8" FLANGED VALVE ASSEMBLY**

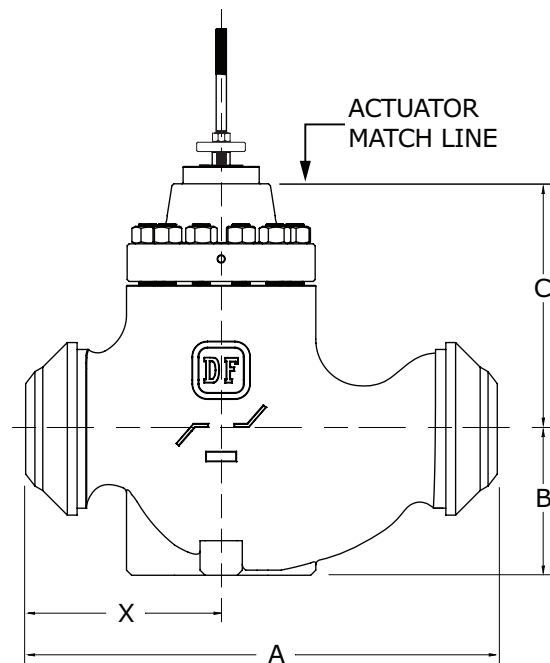

**12X8" BUTTWELD VALVE ASSEMBLY**

**Figure 2** Typical Valve Dimensional Diagrams



# Model 350/351 Control Valves

## Technical Sales Bulletin



**Table 7**

**Valve Body Dimensions - Dimension C for Standard Valve Configurations - inch (mm)**  
 (Refer to Figure 2 on Page 8)

Characteristic	Bonnet	Valve Size inch	Stem Diameter - inch (mm)		
			1/2 (12.7)	3/4 (19.1)	1 & 1-1/4 (25.4 & 31.8)
				ASME Class 150 / 300 / 600	ASME Class 300 / 600
Equal Percentage Quick Opening Linear	Standard	8x6	11.31 (287)	11.31 (287)	13.06 (332)
		10x8	-	14.75 (375)	-
		12x6	14.00 (356)	14.00 (356)	15.75 (400)
		12x8	-	16.19 (411)	-
	Style 1 Extension	8x6	-	15.50 (394)	18.25 (464)
		10x8	-	16.56 (421)	17.69 (449)
		12x6	-	18.19 (462)	20.94 (532)
		12x8	-	18.00 (457)	19.12 (486)
	Style 2 Extension	8x6	-	22.81 (579)	-
		10x8	-	24.44 (621)	-
		12x6	-	25.50 (648)	-
		12x8	-	-	-
Anti-Cavitation	Standard	8x6	15.88 (403)	15.88 (403)	-
		10x8 1-Stage	-	14.75 (375)	16.75 (425)
		10x8 2-Stage	-	20.12 (511)	22.06 (560)
		12x6	18.88 (480)	18.88 (480)	-
		12x8	-	-	-
Low-Noise	Standard	8x6	11.31 (287)	15.69 (399)	17.44 (443)
		10x8	-	19.83 (504)	-
		12x6	14.00 (356)	19.81 (503)	21.56 (548)
		12x8	-	-	-



# Model 350/351 Control Valves

## Technical Sales Bulletin

**Table 8**

### Valve Body Dimensions

(Refer to Figure 2 on Page 8) (For 'C' Dimensions refer to Table 7)

Valve Size Inch	Dimension A - inch (mm)					Dimension B - inch (mm)
	ASME Class 150	ASME Class 300		ASME Class 600		ASME Class 150 / 300/ 600
	RF	RF	RTJ	RF / BWE	RTJ	
8x6	21.38 (543)	22.38 (568)	23.00 (584)	24.00 (610)	24.12 (613)	7.19 (183)
10x8	26.50 (673)	27.88 (708)	28.50 (724)	29.62 (752)	29.75 (756)	10.81 (275)
12x6	29.00 (737)	30.50 (775)	31.12 (791)	32.25 (819)	32.38 (822)	10.00 (254)
12x8	29.00 (737)	30.50 (775)	31.12 (791)	32.25 (819)	32.38 (822)	14.00 (356)

**NOTES:** RF = Raised Face / RTJ = Ring Type Joint / BWE = Butt weld

**Table 9**

### Valve Body Dimensions - Dimension X for 12x8 Valves

(Refer to Figure 2 on Page 8) (For 'C' Dimensions refer to Table 7)

Valve Size Inch	Dimension X - inch (mm)				
	ASME Class 150	ASME Class 300		ASME Class 600	
	RF	RF	RTJ	RF / BWE	RTJ
12x8	11.50 (292)	12.25 (311)	12.56 (319)	13.12 (333)	13.18 (335)

**NOTES:** RF = Raised Face / RTJ = Ring Type Joint / BWE = Butt weld

# Model 350/351 Control Valves

## Technical Sales Bulletin

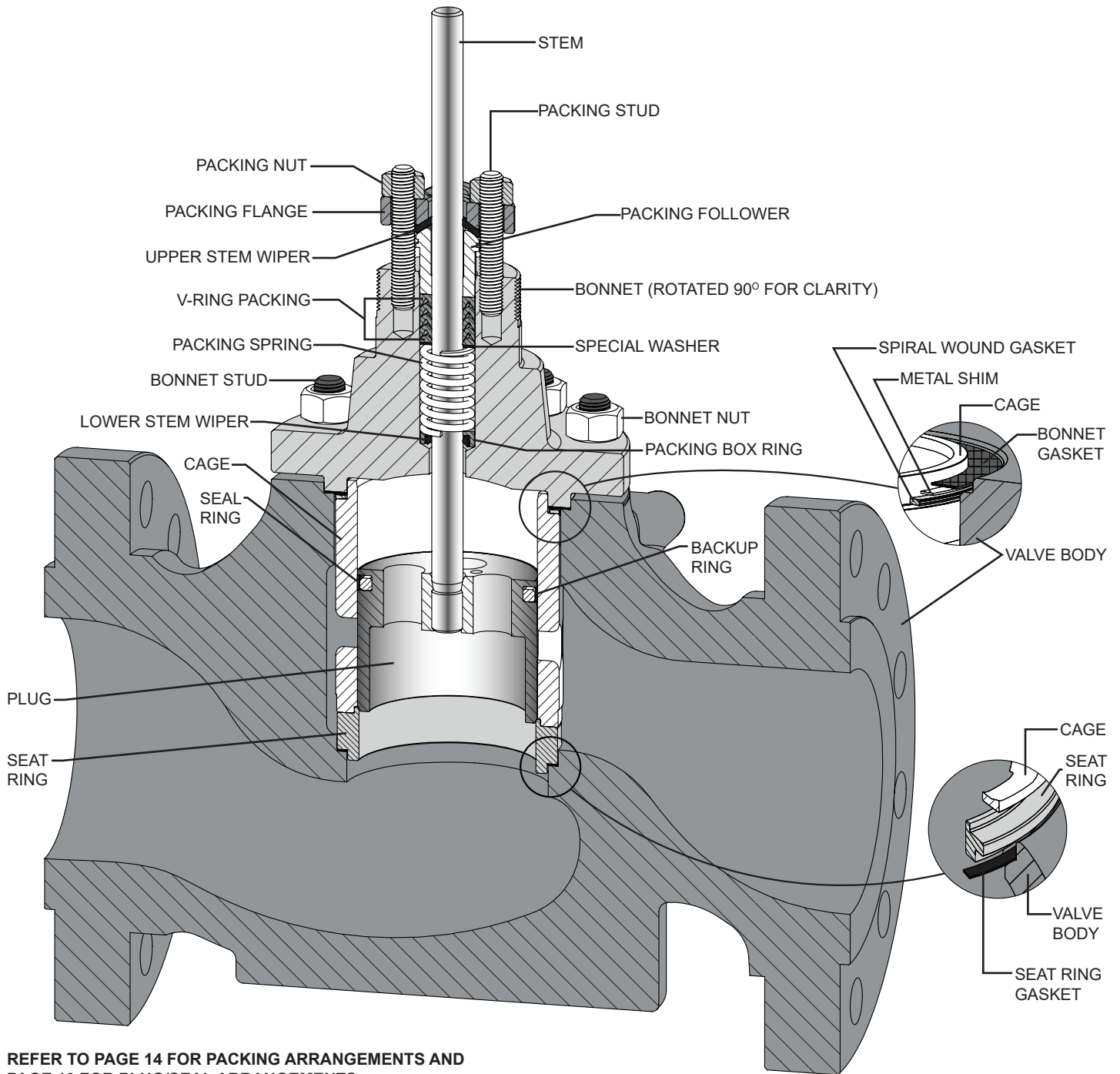

REFER TO PAGE 14 FOR PACKING ARRANGEMENTS AND PAGE 13 FOR PLUG/SEAL ARRANGEMENTS.

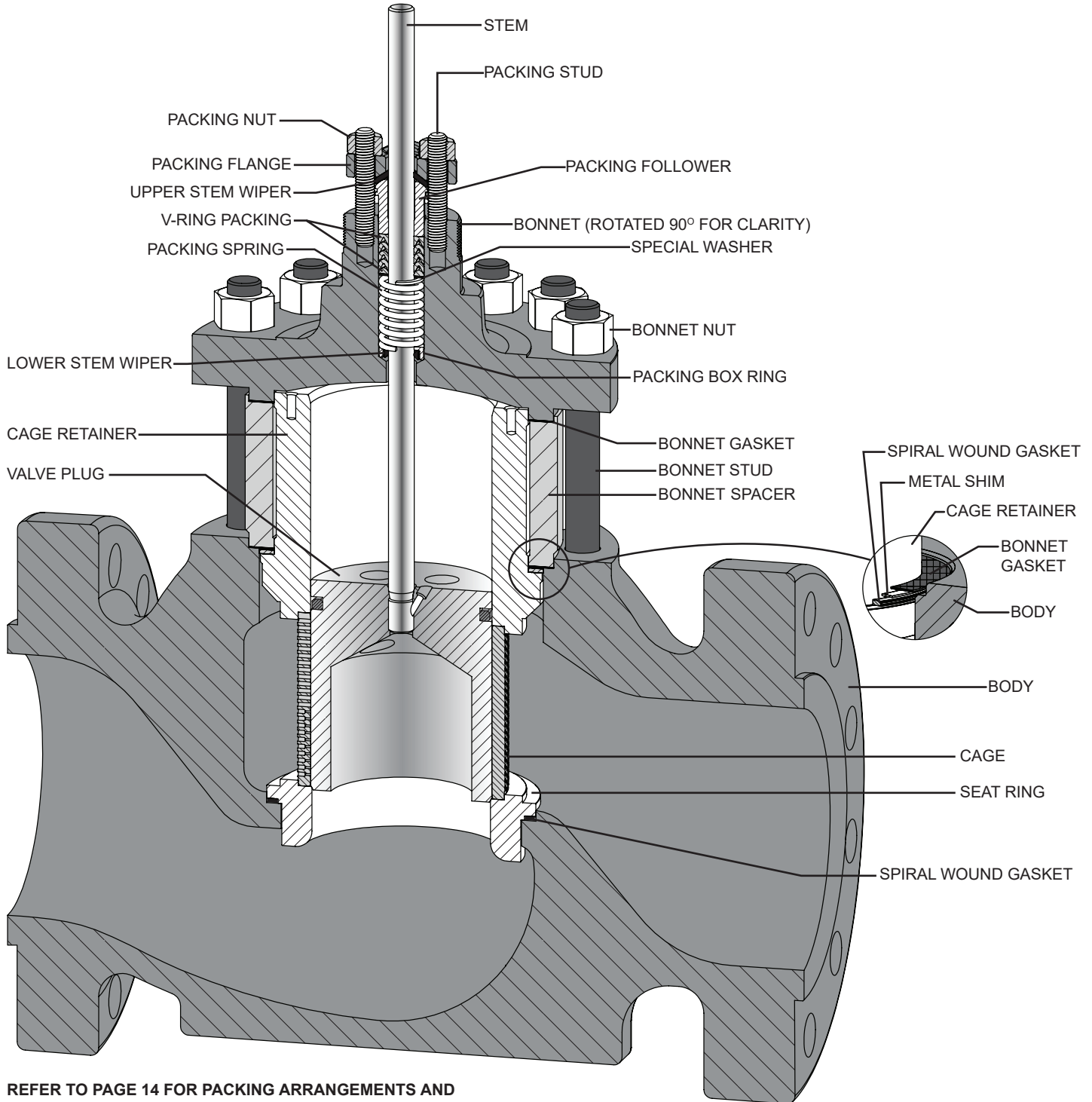

**Figure 3** Standard Valve Assembly up to 7 Inch Port



# Model 350/351 Control Valves

## Technical Sales Bulletin



REFER TO PAGE 14 FOR PACKING ARRANGEMENTS AND PAGE 13 FOR PLUG/SEAL ARRANGEMENTS.

**Figure 4** Standard Low-Noise Valve Assembly up to 7 Inch Port

# Model 350/351 Control Valves

## Technical Sales Bulletin

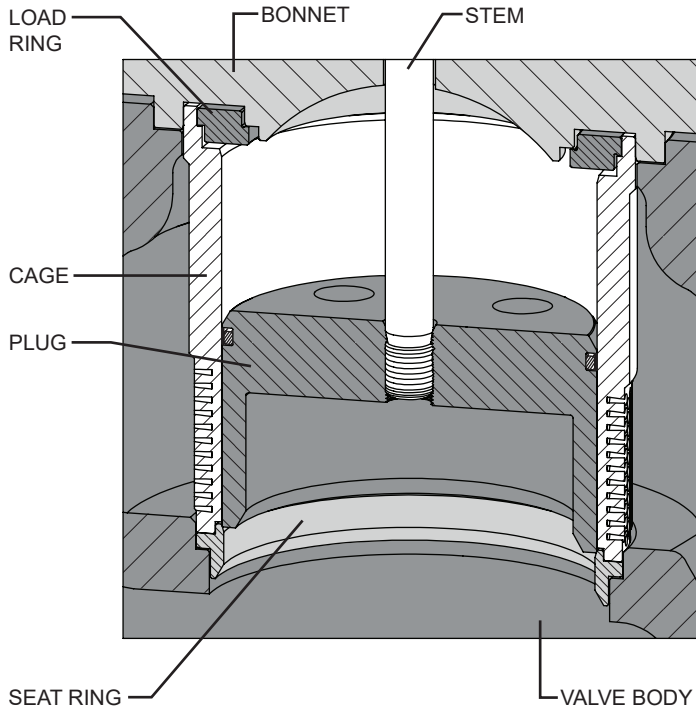

**Figure 5** 10x8 & 12x8 Anti-Cavitation Valve Assembly With Load Ring Detail

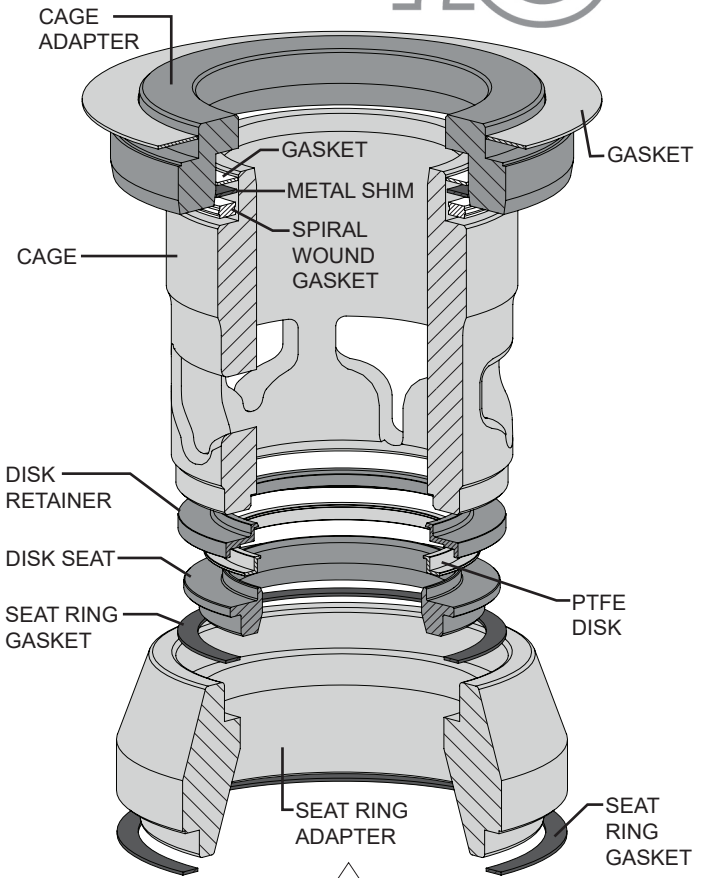

**Figure 6** Reduced Trim Assembly Diagram

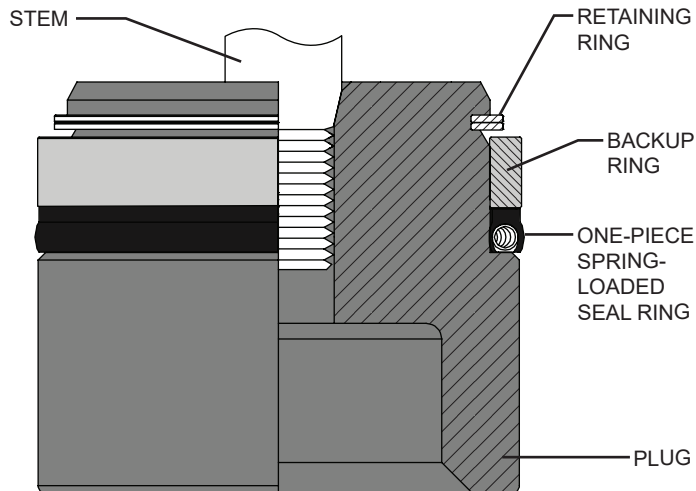

**Figure 7** Spring-Loaded Plug Seal Arrangement

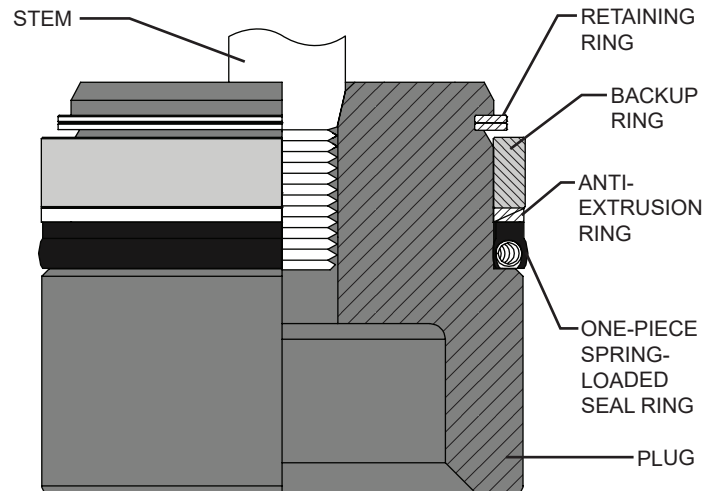

**Figure 8** Spring-Loaded Plug Seal with Anti-Extrusion Ring

# Model 350/351 Control Valves

## Technical Sales Bulletin

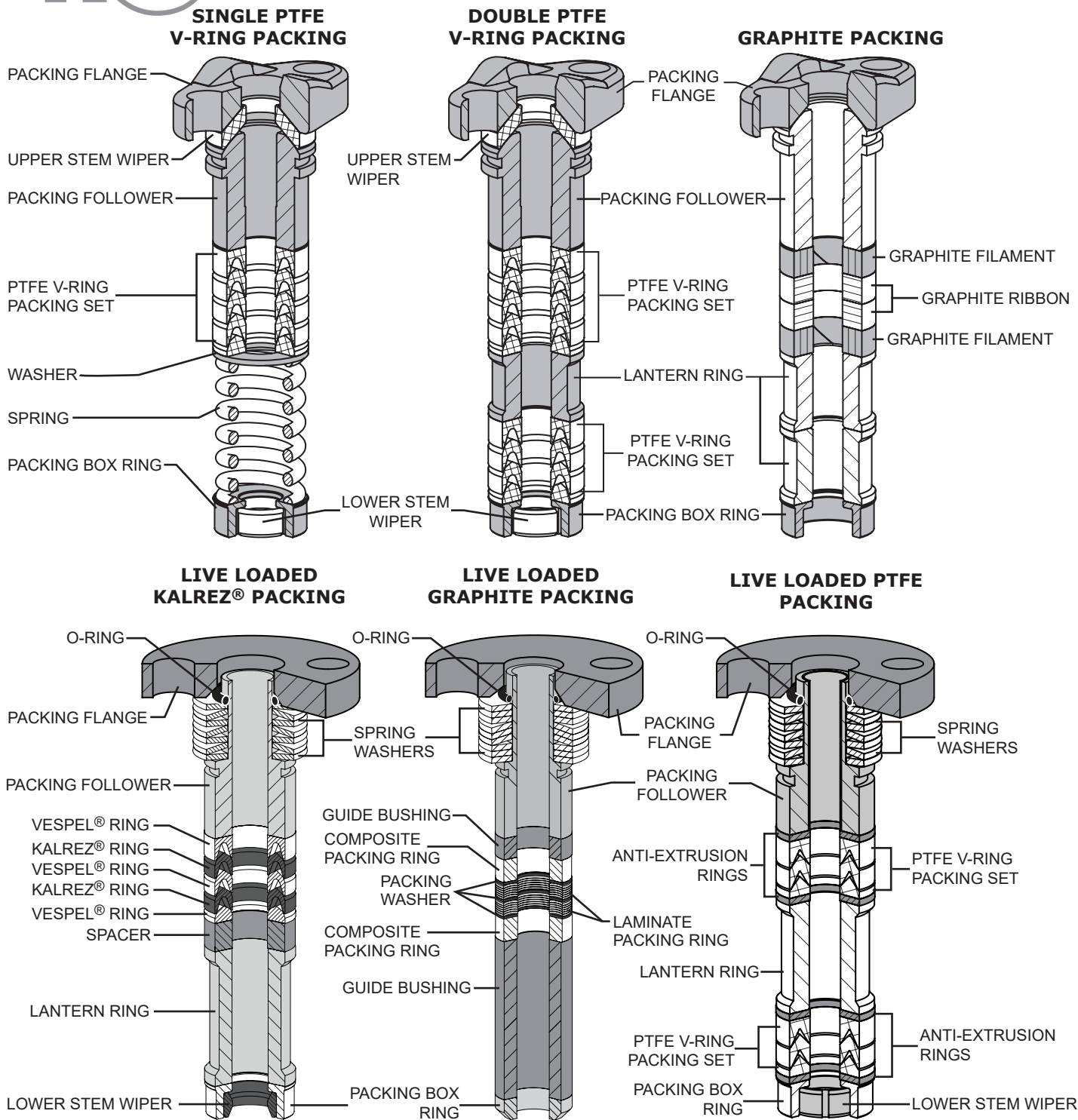

Figure 9 Typical Packing Arrangements

# Model 350/351 Control Valves

## Technical Sales Bulletin



Table 10

### Common Valve Parts Typical Construction Materials and Temperature Limitations

Part	Material	Temperature Limitations			
		Min. °F	Max. °F	Min. °C	Max. °C
Valve Stem	S20910	NLF <sup>(4)</sup>	NLF <sup>(4)</sup>	NLF <sup>(4)</sup>	NLF <sup>(4)</sup>
Load Ring (10x8" & 12x8" Valves Only)	S17400	-150	600	-102	316
Two-Piece Valve Plug Seal <sup>(1)</sup>	Backup Ring	Fluoroelastomer (Viton®) <sup>(7)</sup>			
		Ethylene Propylene <sup>(8)</sup>			
	Seal Ring	-100	450	-73	232
Spring-Loaded (Three-Piece) Valve Plug Seal <sup>(2)(3)</sup>	Backup Ring <sup>(3)</sup>	NLF <sup>(4)</sup>	NLF <sup>(4)</sup>	NLF <sup>(4)</sup>	NLF <sup>(4)</sup>
	Seal Ring	-100	450	-73	232
	Retaining Ring <sup>(3)</sup>	NLF <sup>(4)</sup>	NLF <sup>(4)</sup>	NLF <sup>(4)</sup>	NLF <sup>(4)</sup>
Spring-Loaded (Three-Piece) Valve Plug Seal with Anti-Extrusion Rings <sup>(3)</sup>	Anti-Extrusion Ring <sup>(3)</sup>	NLF <sup>(4)</sup>	NLF <sup>(4)</sup>	NLF <sup>(4)</sup>	NLF <sup>(4)</sup>
	Backup Ring <sup>(3)</sup>	NLF <sup>(4)</sup>	NLF <sup>(4)</sup>	NLF <sup>(4)</sup>	NLF <sup>(4)</sup>
	Seal Ring	-100	600	-73	319
	Retaining Ring <sup>(3)</sup>	NLF <sup>(4)</sup>	NLF <sup>(4)</sup>	NLF <sup>(4)</sup>	NLF <sup>(4)</sup>
Seat Ring / Bonnet / Cage Gaskets	S31600 / Graphite	NLF <sup>(4)</sup>	NLF <sup>(4)</sup>	NLF <sup>(4)</sup>	NLF <sup>(4)</sup>
Spiral Wound Gaskets	S30400 / Graphite	-50	650	-46	343
	N06600 / Graphite (High Temp.)	NLF <sup>(4)</sup>	NLF <sup>(4)</sup>	NLF <sup>(4)</sup>	NLF <sup>(4)</sup>
Piston Ring (Model 351)	Graphite	-50 <sup>(5)</sup>	1100	-46	593 <sup>(5)</sup>
Shim	S30400	NLF <sup>(4)</sup>	NLF <sup>(4)</sup>	NLF <sup>(4)</sup>	NLF <sup>(4)</sup>
Disk	PTFE	-100	400	-73	204
Disk Seat	S31600/S31603 Dual Grade	NLF <sup>(4)</sup>	NLF <sup>(4)</sup>	NLF <sup>(4)</sup>	NLF <sup>(4)</sup>
Disk Retainer	S31600/S31603 Dual Grade	NLF <sup>(4)</sup>	NLF <sup>(4)</sup>	NLF <sup>(4)</sup>	NLF <sup>(4)</sup>
Packing	PTFE V-Ring	-40	450	-40	232
	Graphite (Ribbon/Filament)	-325	1000 <sup>(6)</sup>	-198	537 <sup>(6)</sup>

#### NOTES:

- 1 - Standard for 350 valves sizes 8x6" to 12x6" except those with Anti-Cavitation trim.
- 2 - Standard for 10x8" & 12x8" valves and valves with Anti-Cavitation trim. Optional for 8x6" to 12x6" valves with trim other than Anti-Cavitation.
- 3 - Do not use with 7 inch large or greater port sizes, 8 inch valve assemblies utilize a seal ring only. Anti-extrusion rings will allow for a maximum temperature limitation of 600°F (316°C).
- 4 - NLF - This Material is Not A Limiting Factor. For the temperature limitation refer to the valve body material temperature limit.
- 5 - Limited because of thermal expansion differential between the piston ring and the cage.
- 6 - Oxidizing service limited to 700°F (371°C).
- 7 - Recommended for high-temperature air, hydrocarbons, and some chemicals/solvents. Not recommended for water above 180°F (82°C). Do not use with ammonia or steam.
- 8 - Recommended for hot water and steam. May be used with most fire-resistant hydraulic oils. Do not use with petroleum-based fluids and other hydrocarbons.





# Model 350/351 Control Valves

## Technical Sales Bulletin

<b>Trim Options (Refer to Figures 10 - 14 for Pressure / Temperature Limits)</b>					
<b>Trim Spec</b>	<b>Valve Plug</b>	<b>Stem</b>	<b>Cage</b>	<b>Seat Ring</b>	<b>Service</b>
D1	S41600 HT	S20910	S17400 H900	S41600 HT	Standard / Non-corrosive / High Temp
D2	S31600 <sup>(2)</sup> / Alloy 6 Hard Faced Seat	S20910	S17400 DH1150 <sup>(1)</sup>	S31600 <sup>(2)</sup> / Alloy 6 Hard Faced Seat	Corrosive / NACE High Temperature
D4	S31600 <sup>(2)</sup>	S20910	S17400 H900	S31600 <sup>(2)</sup>	General / Mild Corrosive
D5	S41600 HT	S20910	S17400 H900	S31600 <sup>(2)</sup> / PTFE	Standard / Non-corrosive / Tight Shut off
D6	S31600 <sup>(2)</sup> / Alloy 6 Hard Faced Seat & Guide	S20910	S17400 H900	S31600 <sup>(2)</sup> / Alloy 6 Hard Faced Seat	Standard / Mild Corrosive / Mild Erosive
D7	S31600 <sup>(2)</sup> / Alloy 6 Hard Faced Seat & Guide	S20910	S17400 DH1150	S31600 <sup>(2)</sup> / Alloy 6 Hard Faced Seat	Corrosive / High Temp / NACE / Mild Erosive
D8	S31600 <sup>(2)</sup>	S20910	S17400 DH1150 <sup>(1)</sup>	S31600 <sup>(2)</sup>	NACE / Corrosive
D9	S31600 <sup>(2)</sup>	S20910	S17400 DH1150 <sup>(1)</sup>	S31600 <sup>(2)</sup> / PTFE	NACE / Corrosive / Tight Shut off
DL	S42000 HT	S20910	S17400 H900	S17400 H900	Anti-Cavitation
DJ	S31600 <sup>(2)</sup>	S20910	S31600 <sup>2</sup> / ENC	S31600 <sup>(2)</sup>	NACE
DT	S31600 <sup>(2)</sup>	S20910	S31600 <sup>2</sup> / ENC	S31600 <sup>(2)</sup> / PTFE	NACE
DE	S31600 <sup>(2)</sup> / Alloy 6 Hard Faced Seat & Guide	S20910	S31600 <sup>2</sup> / ENC	S31600 <sup>(2)</sup> / Alloy 6 Hard Faced Seat	NACE
DN	S31600 <sup>(2)</sup> / Alloy 6 Hard Faced Seat & Guide	S20910	S31600 <sup>(2)</sup> / ENC	S31600 <sup>(2)</sup>	NACE Class VI Soft Metal
DR	S31600 <sup>(2)</sup> / Alloy 6 Hard Faced Seat & Guide	S20910	S17400 DH1150	S31600 <sup>(2)</sup>	NACE Class VI Soft Metal

**NOTE:**  
**1** - S31600 (ENC)\* available by special request (\*Electroless Nickel Coating).  
**2** - All S31600 barstock is dual grade S31600/S31603 (316/316L).

<b>Model 350 Class VI Shut-Off Trim Options (Refer to Figures 10 - 12 for Pressure / Temperature Limits)</b>					
<b>Valve Plug</b>	<b>Stem</b>	<b>Cage</b>	<b>Seat Ring</b>	<b>Seal Ring</b>	<b>Temperature Limit</b>
S41600 HT	S20910	S17400 H900	S31600 <sup>(2)</sup>	PTFE/R30003	-20°F to 150°F (-29°C to 66°C)
S41600 HT	S20910	S17400 H900	S31600 <sup>(2)</sup> / PTFE	PTFE/R30003	-20°F to 150°F (-29°C to 66°C)
S31600 <sup>(2)</sup>	S20910	S31600 <sup>2</sup> / ENC	S31600 <sup>(2)</sup> / PTFE	PTFE/R30003	-20°F to 150°F (-29°C to 66°C)
S31600 <sup>(2)</sup> / Alloy 6 Hard Faced Seat	S20910	S31600 <sup>2</sup> / ENC	S31600 <sup>(2)</sup>	PTFE/R30003	-50°F to 150°F (-46°C to 66°C)

**NOTE:**  
**1** - S31600 (ENC)\* available by special request (\*Electroless Nickel Coating).  
**2** - All S31600 barstock is dual grade S31600/S31603 (316/316L).



# Model 350/351 Control Valves

## Technical Sales Bulletin



Table 13

### Body to Bonnet Bolting Temperature Limitations

Body Material	ASME Class	Bolt/Nut Material	Temperature Limitations			
			Min. °F	Max. °F	Min. °C	Max. °C
LCC	150/300/600	B7/2H <sup>(1)(2)</sup>	-50	650	-46	343
		B7M/2HM <sup>(3)</sup>	-50	650	-46	343
WCC/WC9	150/300/600	B7/2H <sup>(1)(2)</sup>	-20	800	-29	427
		B7M/2HM <sup>(3)</sup>	-20	800	-29	427
CF8M	150/300/600	B7 Fluorokote #1 / 2H Fluorokote #1 (Standard) <sup>(2)</sup>	-50	500	-46	260
		B8M/8M <sup>(2)</sup>	-325	800	-198	427
		B7M Fluorokote #1/ 2HM Fluorokote #1 <sup>(3)</sup>	-50	500	-46	260

**NOTES:**

- 1 - Standard non-NACE option.
- 2 - NACE MR0175/ISO15156 Non-Exposed Bolting option (Bolting that is not directly exposed to sour environments and is not to be buried, insulated, equipped with flange protectors, or otherwise denied direct atmospheric exposure).
- 3 - NACE MR0175/ISO15156 Exposed Bolting option (Bolting that will be exposed directly to the sour environment or that will be buried, insulated, equipped with flange protectors, or otherwise denied direct atmospheric exposure).

Table 14

### Bonnet and Packing Selection<sup>(1)</sup>

Bonnet Style	Packing Material	In-Body Process Temperature Limitations
<b>Standard Bonnet:</b> Standard for valve sizes 8x6 through 12x6.	PTFE V-Ring	0°F to 450°F (-18°C to 232°C) <sup>(2)</sup>
	Graphite (Ribbon/Filament)	0°F to Table 10 limits (-18°C to Table 10 limits)
<b>Style 1 Extension Bonnet:</b> Optional for valve sizes 8x6 through 12x6. Standard for valve sizes 10x8 and 12x8.	PTFE V-Ring	-50°F to 800°F (-46°C to 427°C)
	Graphite (Ribbon/Filament)	Refer to maximum Table 10 limits
<b>Style 2 Extension Bonnet:</b> Optional for valve sizes 8x6 through 12x6. Optional for valve sizes 10x8 and 12x8.	PTFE V-Ring	-150°F to 800°F (-101°C to 427°C)
	Graphite (Ribbon/Filament)	Refer to maximum Table 10 limits

- 1 The above temperatures assume the presence of an ambient temperature outside the valve body of 70°F (21°C) with no bonnet insulation. An extension bonnet may be required when operating valves in low temperatures to prevent damage that could occur from the formation of valve stem frost. Other limiting factors, such as trim material components, will have to be considered.
- 2 Consult Dyna-Flo for temperatures above 450°F (232°C).

**NOTE:** For temperatures above or below these standard temperatures consult Dyna-Flo.



# Model 350/351 Control Valves

## Technical Sales Bulletin

**Table 15**

**Standard<sup>(1)</sup> Valve Body/Trim Option Temperature Limitations for ASME Class 150 - 600**  
**(Refer to Figures 10 - 12 for Pressure/Temperature limits)**

Body Material	Trim Designation	Valve Size inch	Temperature Limitations			
			Min. °F	Max. °F	Min. °C	Max. °C
LCC	D1	8x6	-20	625	-29	329
		12x6	-20	500	-29	260
		10x8 & 12x8	-20	650	-29	343
	D5	8x6 through 10x8	-20	400	-29	204
	D6	All Sizes	-50	410	-46	210
	DJ	8x6	-50	400	-46	204
		12x6	-50	325	-46	163
		10x8 & 12x8	-50	600	-46	316
	CF8M	DJ / DE	All Sizes	-325	600	-198
WCC	D1	8x6	-20	600	-29	316
		12x6	-20	500	-29	260
		10x8 & 12x8	-20	800	-29	427
	D5	All Sizes	-20	400	-29	204
	D6	All Sizes	-20	410	-29	210
	DJ	8x6	-20	400	-29	204
		12x6	-20	345	-29	174
		10x8 & 12x8	-20	600	-29	316
	WC9	D1	8x6	-20	600	-29
12x6			-20	500	-29	260
10x8 & 12x8			-20	800	-29	427
D5		All Sizes	-20	400	-29	204
D6		All Sizes	-20	410	-29	210
DE		8x6	-20	400	-29	204
		12x6	-20	325	-29	163
		10x8 & 12x8	-20	650	-29	343
DJ		8x6	-20	400	-29	204
		12x6	-20	325	-29	163
		10x8 & 12x8	-20	600	-29	316

**NOTES:**

**1** - For metal trim parts only. Not to be used with Low-Noise or Anti-Cavitation trim.

# Model 350/351 Control Valves

## Technical Sales Bulletin



**Table 16**

**Anti-Cavitation Valve Body/Trim Option Temperature Limitations  
(Refer to Figures 10 - 12 for Pressure/Temperature limits)**

Body Material	Trim Designation	Valve Size inch	Temperature Limitations			
			Min. °F	Max. °F	Min. °C	Max. °C
LCC	DL	All Sizes	-50	NLF <sup>(1)</sup>	-46	NLF <sup>(1)</sup>
CF8M	DL	8x6	-20	250	-29	121
		12x6	-20	225	-29	107
		12x8 <sup>(2)</sup>	-20	350	-29	177
WCC & WC9	DL	All Sizes	-20	NLF <sup>(1)</sup>	-29	NLF <sup>(1)</sup>

**NOTES:**

- 1** - NLF - This Material is Not A Limiting Factor. For the temperature limitation refer to the valve body material temperature limit.
- 2** - Available for all 12x8 ASME Class ratings.



# Model 350/351 Control Valves

## Technical Sales Bulletin

**Table 17**

**Low-Noise<sup>(1)</sup> Valve Body/Trim Option Temperature Limitations**  
 (Refer to Figures 10 - 12 for Pressure/Temperature limits)

Body Material	Trim Designation	Valve Size inch	Temperature Limitations			
			Min. °F	Max. °F	Min. °C	Max. °C
CF8M	D1	8x6	-20	300	-29	149
		10x8	-20	300	-29	149
		12x8	-20	300	-29	149
	D5	8x6	-20	300	-29	149
		10x8	-20	300	-29	149
		12x8	-20	300	-29	149
	DE	8x6	-325	650	-198	343
		10x8	-325	650	-198	343
		12x8	-325	650	-198	343
	DE 5-3/8" (136.5 mm) Port	8x6	-20	650	-29	343
		12x6	-20	650	-29	343
	WCC & WC9	D1	8x6	-20	800	-29
10x8			-20	800	-29	427
12x8			-20	800	-29	427
D5		8x6	-20	400	-29	204
		10x8	-20	400	-29	204
		12x8	-20	400	-29	204
DE		8x6	-20	600	-29	316
		10x8	-20	600	-29	316
		12x8	-20	600	-29	316
DE 5-3/8" (136.5 mm) Port		8x6	-20	400	-29	204
		12x6	-20	350	-29	177

**NOTES:**

1 - For metal trim parts only. Not to be used with Standard or Anti-Cavitation trim.

# Model 350/351 Control Valves

## Technical Sales Bulletin



**Table 18**

**Notes For Trim Pressure / Temperature Charts - Refer to Figures 10 to 14.**

<b>NOTES:</b>	<b>Refer to the ASME Class Rating or the body material being used, DO NOT exceed these Pressure/Temperature Limitations even though trim limitations may be better.</b>
	<b>1</b> Trim can be used to 1,440 Psi (99 bar) when used with clean dry gas. When used with other process fluids, do not exceed 300 Psi (21 bar).
	<b>2</b> Trim temperature limitations can be extended to 600°F (316°C) when used for non-oxidizing service or 500°F (260°C) with oxidizing service when using PEEK anti-extrusion rings and spring-loaded seal rings.
	<b>3</b> Temperatures above 450°F (232°C) require a spring-loaded seal ring and PEEK anti-extrusion rings.
	<b>4</b> Use trim DE instead of DJ for non-lubricating fluids (such as dry gas or steam) between 300°F (149°C) and 450°F (232°C).
	<b>5</b> Can be used over 300 Psi (21 bar) with clean, dry gas.
<b>6</b> Temperature limits can be extended down to -150°F (-101°C) with Low-Noise III style A, B, or C cages, or with style D cage that has an 18-8 SST baffle.	

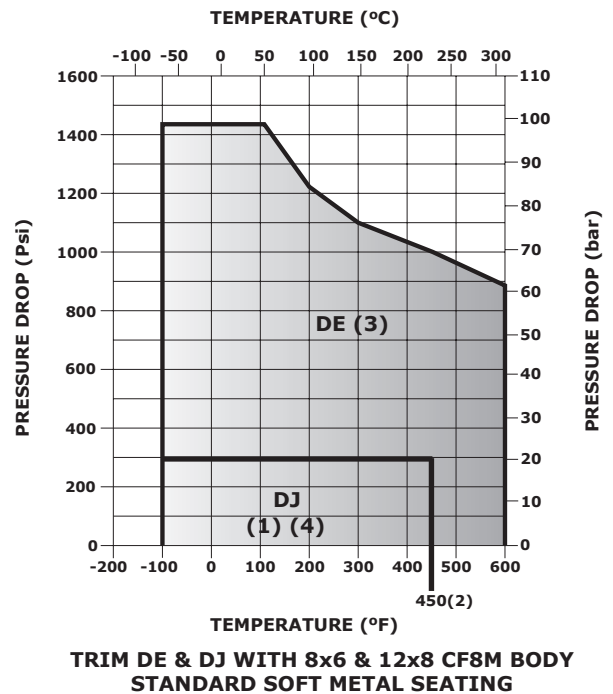
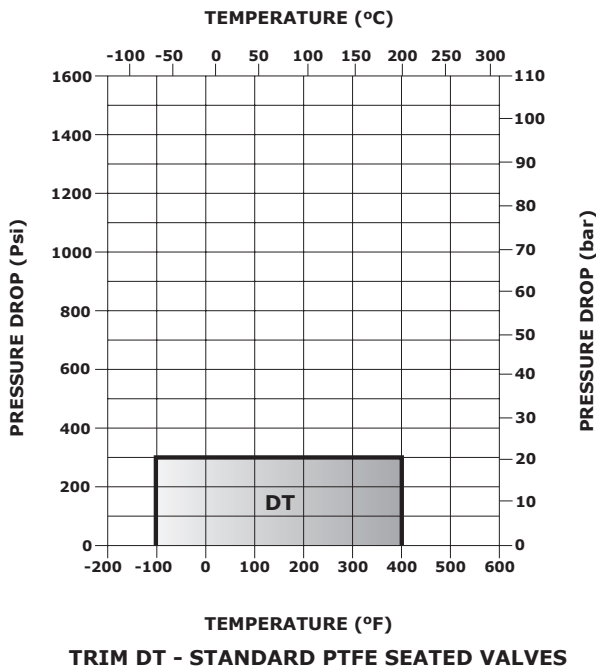

**Figure 10** Typical Valve Trim Pressure and Temperature Limitations for Soft Seated Valves

# Model 350/351 Control Valves

## Technical Sales Bulletin

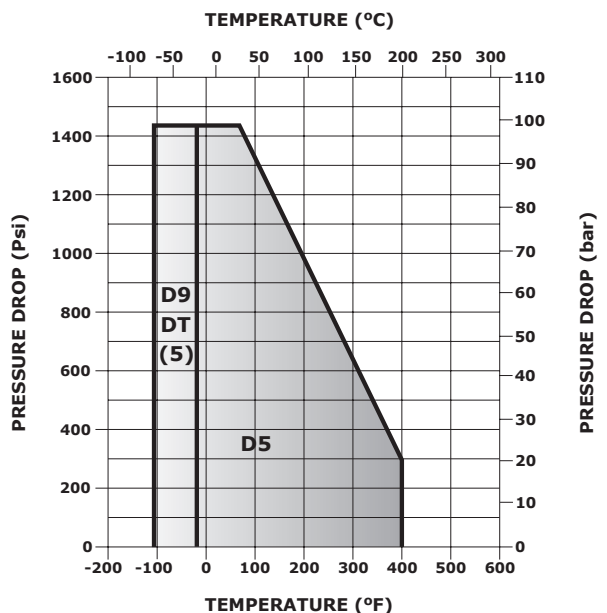

TRIM D5, D9, & DT FOR PTFE SEATED ASME CLASS 600 VALVES

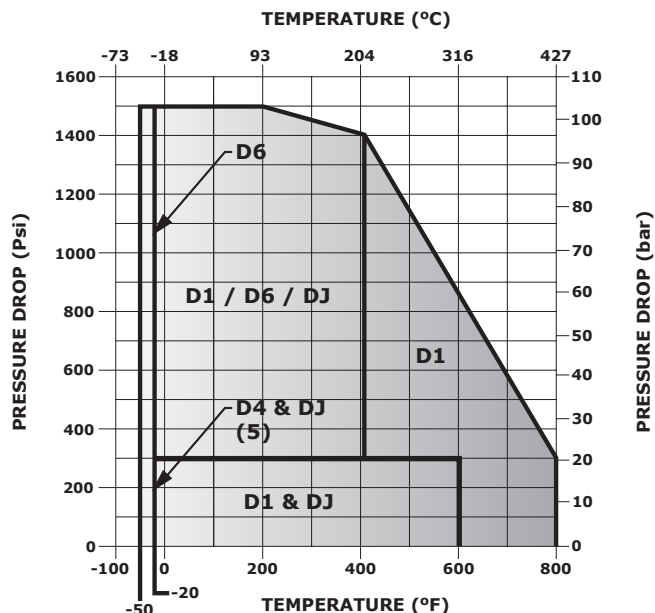

TRIM D1, D4, D6, & DJ WITH LCC OR WCC FOR ASME CLASS 600 VALVES

Figure 11 Typical Valve Trim Pressure and Temperature Limitations for Standard Valves

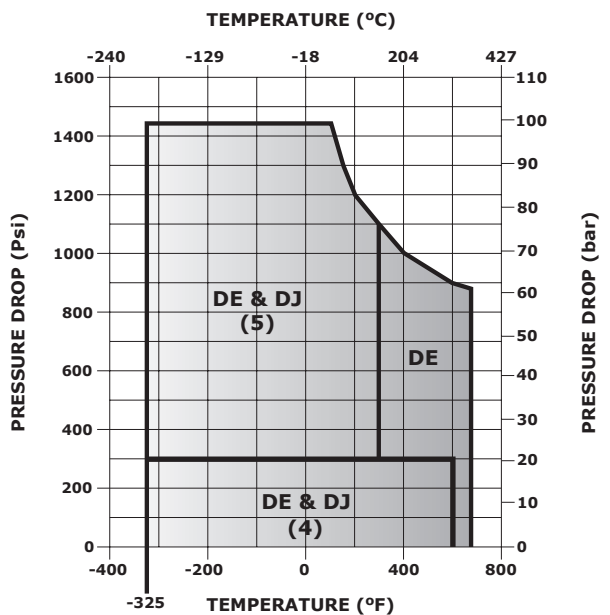

TRIM DE & DJ WITH CF8M ASME CLASS 600 VALVES

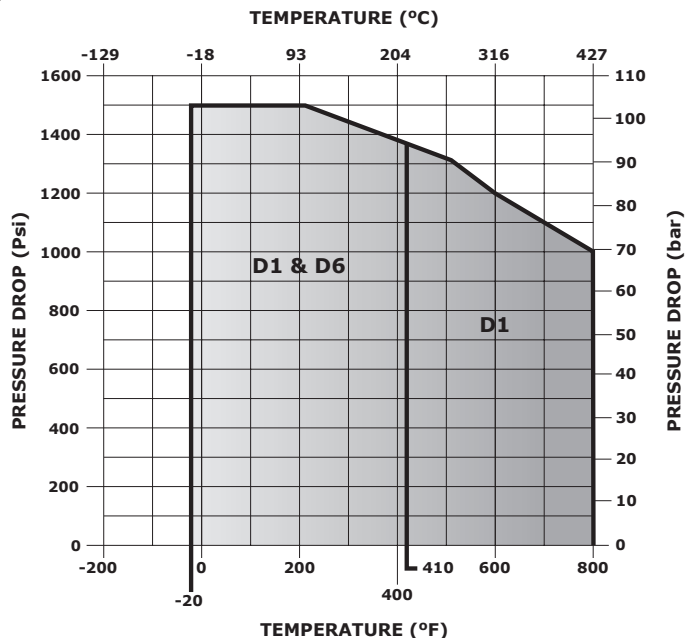

TRIM D1 & D6 WITH WC9 FOR ASME CLASS 600 VALVES

# Model 350/351 Control Valves

## Technical Sales Bulletin

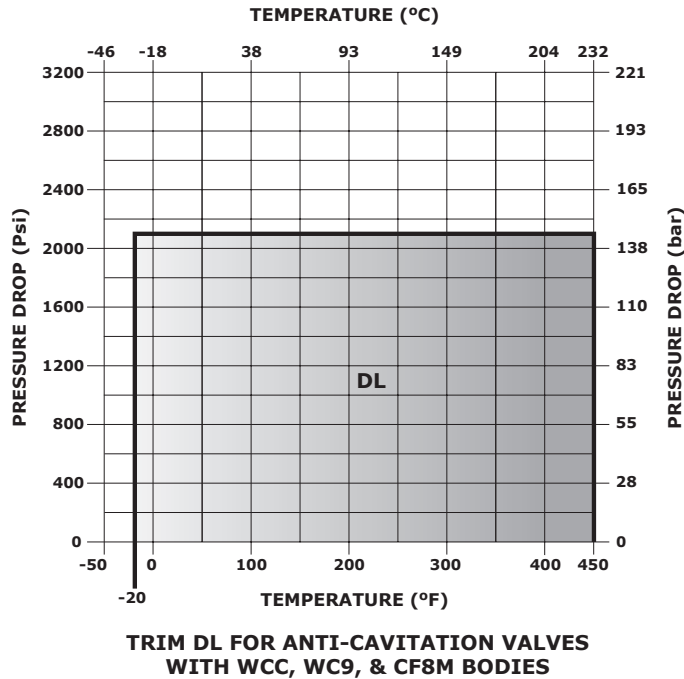

**Figure 12** Typical Valve Trim Pressure and Temperature Limitations for Anti-Cavitation Trim

### ***Our Commitment to Quality***

Curtiss-Wright Flow Control Company Canada is committed to continuous improvement. While all efforts have been made to ensure the accuracy of the content in this document, modifications or improvements to the information, specifications, and designs may occur at any time without notice. This document was published for informational purposes only, and does not express or imply suitability, a warranty, or guarantee regarding the products or services described herein or their use or applicability.

Neither Curtiss-Wright Flow Control Company, nor any of their affiliated entities assumes responsibility for the selection, use and maintenance of any product. Responsibility for selection, use and maintenance of any product remains with the purchaser and end-user.



# Model 350/351 Control Valves

## MODEL NUMBERING SYSTEM

SAMPLE PART NUMBER: 350-64AFL-5P2-VES4

						<b>VALVE SIZE</b>		<b>64</b>	
<b>86</b>	8X6 INCH	<b>126</b>	12X6 INCH	<b>108</b>	10X8 INCH	<b>128</b>	12X8 INCH		
<b>ASME RATING</b>								<b>A</b>	
<b>A</b>	150	<b>B</b>	300	<b>C</b>	600				
<b>END CONNECTION</b>									
<b>F</b>	RF	<b>J</b>	RTJ	<b>N</b>	NPT	<b>T</b>	BWE SCH 40	<b>F</b>	
<b>L</b>	BWE SCH 80								
<b>BODY MATERIAL</b>								<b>L</b>	
<b>L</b>	LCC	<b>W</b>	WCC	<b>M</b>	CF8M	<b>9</b>	WC9		
<b>BOLTING</b>									
-	B7 / 2H (STANDARD)			<b>A</b>	B7M / 2HM			<b>-</b>	
<b>B</b>	B8M / 8M			<b>K</b>	B7 FLUOROKOTE #1 / 2H FLUOROKOTE #1				
<b>L</b>	B7M FLUOROKOTE #1 / 2HM FLUOROKOTE #1								
<b>TRIM</b>								<b>5</b>	
<b>1</b>	TRIM D1	<b>2</b>	TRIM D2	<b>4</b>	TRIM D4	<b>5</b>	TRIM D5		
<b>6</b>	TRIM D6	<b>7</b>	TRIM D7	<b>8</b>	TRIM D8	<b>9</b>	TRIM D9		
<b>L</b>	TRIM DL	<b>J</b>	TRIM DJ	<b>T</b>	TRIM DT	<b>E</b>	TRIM DE		
<b>N</b>	TRIM DN	<b>R</b>	TRIM DR						
<b>PACKING STYLE</b>								<b>P</b>	
<b>P</b>	SINGLE PTFE V-RING (PRESSURE)			<b>J</b>	DOUBLE PTFE V-RING (PRESSURE)				
<b>G</b>	SINGLE GRAPHITE (PRESSURE)			<b>V</b>	DOUBLE PTFE V-RING (VACUUM)				
<b>R</b>	DOUBLE PTFE V-RING (VACUUM / PRESSURE)			<b>L</b>	LIVE LOADED PTFE V-RING (PRESSURE)				
<b>T</b>	LIVE LOADED GRAPHITE (PRESSURE)			<b>D</b>	LIVE LOADED DUPLEX (PRESSURE)				
<b>K</b>	LIVE LOADED KALREZ® (PRESSURE)			<b>F</b>	LIVE LOADED KALREZ® FIRE SAFE (PRESSURE)				
<b>YOKE BOSS SIZE</b>								<b>2</b>	
<b>2</b>	2-13/16" (1/2" STEM)			<b>3</b>	3-9/16" (3/4" STEM)				
<b>5</b>	5" (1" STEM)			<b>6</b>	5H (1-1/4" STEM)				
<b>PAINT</b>								<b>-</b>	
-	DFPS-01 (STANDARD)			<b>2</b>	DFPS-02 (SEVERE SERVICE)				
<b>3</b>	DFPS-03 (HIGH TEMPERATURE)								
<b>BACKUP RING / SEAL RING</b>								<b>V</b>	
<b>V</b>	VITON / CARBON-FILLED PTFE			<b>E</b>	EPDM / CARBON-FILLED PTFE				
<b>P</b>	PTFE-ELGILOY (8" 350)			<b>C</b>	S31600 / PTFE-ELGILOY				
<b>R</b>	S31600 / PTFE-ELGILOY WITH PEEK AE RINGS			<b>K</b>	S31600 / KEL-F - ELGILOY				
<b>CHARACTERISTIC</b>								<b>E</b>	
<b>E</b>	EQUAL PERCENT	<b>L</b>	LINEAR	<b>Q</b>	QUICK OPENING				
<b>A</b>	ANTI-CAVITATION 1 STAGE (LINEAR)			<b>K</b>	ANTI-CAVITATION 2 STAGE (LINEAR)				
<b>Z</b>	LOW-NOISE III A1 (LINEAR)			<b>Y</b>	LOW-NOISE III B3 (LINEAR)				
<b>C</b>	LOW-NOISE III C3 (LINEAR)			<b>1</b>	LOW-NOISE III D1 (LINEAR)				
<b>D</b>	LOW-NOISE III D3 (LINEAR)								
<b>CHARACTERISTIC (EXTENDED TRAVEL)</b>									
<b>R</b>	EQUAL PERCENT - EXTENDED TRAVEL			<b>S</b>	LINEAR - EXTENDED TRAVEL				
<b>T</b>	QUICK OPENING - EXTENDED TRAVEL			<b>V</b>	ANTI-CAVITATION 1 STAGE (LINEAR) - EXTENDED TRAVEL				
<b>P</b>	LOW-NOISE I (LINEAR) - EXTENDED TRAVEL			<b>W</b>	LOW-NOISE III A1 (LINEAR) - EXTENDED TRAVEL				
<b>4</b>	LOW-NOISE III A1 (LINEAR) EXTENDED 4" TRAVEL (8" VALVE ONLY)								
<b>BONNET STYLE</b>								<b>S</b>	
<b>S</b>	STANDARD		<b>T</b>	STANDARD TAPPED		<b>E</b>	EXTENSION STYLE 1		
<b>H</b>	EXTENSION STYLE 2								
<b>SHUT-OFF CLASS</b>								<b>4</b>	
<b>2</b>	CLASS II		<b>3</b>	CLASS III		<b>4</b>	CLASS IV		
<b>5</b>	CLASS V						<b>6</b>		CLASS VI

350