

Model 370 & 371 Control Valves

Operation, Parts, and Instruction Manual



Figure 1 12" 370 Control Valve & DFLP 154 Actuator

TABLE OF CONTENTS

General	2	Assembly	14
Scope	2	Stud Installation	14
Specifications	3	Plug / Seal Assembly	14
Unpacking	4	Trim Parts Assembly	16
Installation	4	Bonnet Installation	19
Air Piping	4	Packing Installation	20
Periodic Inspection	5	Body to Bonnet Bolting Torques - Table 2	23
Maintenance	5	Packing Bolt Torques - Table 3	23
Packing Maintenance	5	Model 371 Seat Ring Cap Screw Torques - Table 4	23
Actuator Removal	6	Model 370 Valve Cross Section - Figure 33	26
Disassembly	8	Model 371 Valve Cross Section - Figure 34	26
Packing Removal	8	Parts	28
Bonnet Removal	8	Model Builder	36
Trim Parts Removal	9		
Plug Seal Removal	13		
Packing Parts Removal	13		



Model 370 & 371 Control Valves

Operation, Parts, and Instruction Manual

NOTICE

These instructions are meant to be used with the Dyna-Flo 370 and 371 Technical Sales Bulletin as they refer to Figures and Tables therein. If you do not have the Technical Sales Bulletin, contact Dyna-Flo immediately, or visit www.dynaflo.com.

Each control valve is factory checked. Check the calibration for the specific application, before a valve is put into service.

It is the intention of this document to provide users with an accurate guide for safe installation and maintenance of the 370/371 Control Valves. Revisions and updates are available at above mentioned website.

GENERAL

The following instructions are to be thoroughly reviewed and understood prior to installing, operating or performing maintenance on this equipment. Work on this equipment should be performed by experienced personnel. Throughout the manual, safety and caution notes appear and must be strictly followed to prevent serious injury or equipment malfunction.

SCOPE

The control valve configuration and construction materials were selected to meet particular pressure, temperature, and process conditions. Some material combinations are limited in their pressure and temperature ranges. Do not apply any other conditions to the valve without first contacting your Dyna-Flo sales office.

This manual is written to be a practical and useful guide maintaining the Dyna-Flo 370 and 371 Control Valve.

SAFETY CAUTION

Only well trained experienced technicians should perform these procedures. Use safe work practices and lock out procedures when isolating valves and actuators. It is also important to wear the proper protective equipment when performing any installation or maintenance activity. Use only parts and materials rated for the process being used, operating conditions, and environmental conditions products will be used in.

To avoid personal injury or installation damage as a result of the sudden release of process pressure or damage to equipment, do not install the valve assembly where service conditions could exceed the limits stated in this manual, sales bulletin or on the equipment nameplates. Use government codes, accepted industry standards and good piping practices, and select proper pressure-relieving equipment for protection of your installation. Always be aware of flammable process and instrument gas.

Always be aware of the hazards of actuators, especially spring-loaded actuators. Be sure that the actuator is de-energized or in the failed position before performing any maintenance procedure.

These valves have dangerous pinch points. Never put your hands inside the valve unless you are certain that the plug and stem will not move.

Model 370 & 371 Control Valves

Operation, Parts, and Instruction Manual



SPECIFICATIONS

Configurations

The Model 370/371 control valve is a high capacity single port, globe style valve, with a bolted type bonnet. The standard valve plug action is push down to close.

Consult your Dyna-Flo sales office for other available configurations.

Sizes and Connection Styles

Models: 370 & 371

Size: 12", 14", and 16"

Rating: ASME 150 / 300 / 600

Connections: RF

Maximum Inlet Pressures and Temperatures

Flanged valves consistent with ASME Class rating as per ASME B16.34, unless limited by material, pressure or temperature limitations.

Maximum Pressure Drops

Maximum pressure drop is the same as maximum inlet pressure unless otherwise rated by a specific trim construction.

Standard Shut-off Classifications

In accordance with ANSI/FCI 70.2 and IEC 60534-4

Model 370 Metal Seat: Class V Standard. Class IV Optional.

Model 370 Anti-Cavitation 2 Stage: Class V Standard.

Model 371 Metal Seat: Class IV Standard.

Flow Direction

Flow Down (Standard)

Low-Noise Trim - Flow Up

Anti-Cavitation Trim - Flow Down

Dimensions

Valve Outline Dimension Diagram

Refer to Figure 2 of the Sales Bulletin.

Valve Assembly Dimensions

Refer to Tables 3 & 4 of the Sales Bulletin.

Approximate Valve Body and Actuator Weights

Refer to Table 1.

Materials

Body and bonnet material options include:

LCC (A350-LF2 optional* bonnet material)

WCC (A350-LF2 optional* bonnet material)

CF8M (A182-F316 optional* bonnet material)

***NOTE:** Dyna-Flo reserves the right to substitute a cast material with the forged bar equivalent in the event a casting is not available.

Refer to Tables 5 & 6 of the Sales Bulletin for typical construction materials. Refer to Table 7 of the Sales Bulletin for trim selections.

Cross-Section of the Model 370/371 Control Valves

Refer to Figures 33 & 34.

Characteristics, Port Diameters, Stem and Yoke Boss

Refer to Table 1 of the Sales Bulletin.

4 to 8 inch (102 to 203 mm) Available Plug Travel.

Packing Type and Examples

The Standard packing is PTFE V-ring. Live-loaded low emission, graphite and other packing arrangements are available. Refer to the Model Builder and Figures 30 to 32.

Valve Sizing Coefficients

For standard coefficients at maximum travel, refer to Table 9 of the Sales Bulletin. For full list of coefficients refer to document P-CVSM.

For more information and other options contact your Dyna-Flo sales office.



Model 370 & 371 Control Valves

Operation, Parts, and Instruction Manual

UNPACKING VALVE FROM SHIPPING CONTAINER

Special Tools Required:

- Properly Rated Lifting Straps (2 – 4 Straps) See Table 1 for valve weights.
- Lifting Device (Example: Crane)

Check the packing list, verify that the list includes all the materials in the shipping container before unpacking. Valve information can be found on the nameplate (Key 45).

When lifting the valve from the shipping container, place properly rated lifting straps to avoid damaging tubing and other mounted accessories.

INSTALLATION

Before You Begin:

- Read the General and Scope section of this manual (Page 2).
- Read Safety Caution (Page 2).
- Sudden movement of actuator can cause damage or injury. It helps to have the actuator de-energized.
- Use safe work practices and lock out procedures before placing valve in-line.

Parts Required:

- Appropriate Line Flange Nuts and Bolts
- Appropriate Line Flange Gaskets
- If the valve has small internal flow passages such as Anti-Cavitation or Low-Noise trim, the installation of an upstream strainer should be considered to prevent clogging of these small passages.

Installation Steps:

- 1 Check the packing box bolting (Key 33) for proper tightness. Refer to Packing Installation on Page 20 for proper packing tightening instructions.
- 2 The control valve should be installed with the actuator vertical above the valve body. This facilitates installing the cage assembly into the valve body without damaging the seat ring, seal ring or mating chamfers. Vertical installation minimizes bending of the stem as well as uneven wearing on the plug and cage, significantly extending the life of the valve.

- 3 Install the valve with flow through the valve in the direction shown by the flow arrow on the valve body.
- 4 Install the appropriate line flange gaskets.
- 5 Apply anti-seize compound to the threads of the flange studs and install.
- 6 When possible, before tightening the line bolting, stroke the valve and check for smooth operation through the full stroke. Unsteady valve stem movement could be an indication of an internal problem.
- 7 Tighten the line flange bolting in even increments in a crisscross pattern until the correct line bolt torque specification is reached.

AIR PIPING

WARNING:

Property damage, environmental harm, and personal injury can result from the use of supply gas other than clean, non-corrosive, oil and moisture free air. Do not exceed the supply pressure indicated on the serial plate located on the actuator.

Before You Begin:

Note: Standard actuators accept 1/4" (6 mm) NPT connections.

- Refer to the appropriate actuator instruction manual when necessary.

Piping Installation Steps:

- 1 Use 3/8" (outside diameter) tubing (or equivalent) for air lines.
- 2 Install the required line vents, valves, drains, seals, and filters to the actuator.

Model 370 & 371 Control Valves

Operation, Parts, and Instruction Manual



Table 1

Approximate Valve Weights

Valve Size (inch)	End Connection	lb	Kg
12	RF	3100	1410
14	RF	3450	1565
16	RF	3800	1720

PERIODIC INSPECTION

Special Equipment Required:

- Bypass or block valves.

Before You Begin:

- Read Safety Caution (Page 2).
- Use safe work practices and lock out procedures.
- Disconnect supply lines (air or gas), electric power, or control signal to the actuator. Sudden movement of actuator can cause damage or injury, make sure actuator will not operate.
- Vent any pneumatic actuator loading pressure and relieve any actuator spring preload if present.
- Relieve process pressure and drain the process fluid from up and down stream of valve.
- Be aware of potentially hazardous process material that may be present in-line and in-valve. Isolate the valve from process pressure. Use a bypass or block valve if necessary, or completely shut off the process.

Inspection Steps:

- 1 Check for visible signs of leakage around all seal and gasket areas.
- 2 Check the valve for damage, especially damage caused by corrosive fumes or process drippings.
- 3 Clean and repaint the areas as required.
- 4 Ensure all accessories, mounting brackets, and fasteners are secure.
- 5 Clean any dirt and foreign material from the valve stem (Key 5).

MAINTENANCE

Note: Seals, soft parts, and packing (including live loaded packing) should all be inspected frequently for leaks, wear and damage. Maintenance to the valve can be performed while the valve is still in-line, the actuator must be removed to replace packing (See Page 6 for Actuator Removal instructions).

Before you begin:

- Read Safety Caution (Page 2).
- Determine if valve has regular or live loaded packing (See Figures 28, 30, 31, & 32).
- Follow Steps 1 – 6 of Before You Begin from PERIODIC INSPECTION (Page 6).

Packing Maintenance

If the packing is leaking, proper tightening of the packing may correct the leak. If re-tightening the packing to the proper specifications does not stop the leakage, it is possible that the stem or wall of the packing box is damaged. Replace or repair parts as necessary. For instructions on packing removal only, refer to the Disassembly, Packing Removal section on Page 8.

- 1 Determine the type of packing installed in the valve. Refer to Figures 28, 30, 31, and 32 for packing styles.

For Single PTFE V-Ring Packing (Spring-Loaded):

Tighten the packing nuts (Key 33) evenly in an alternating pattern until the shoulder of the packing follower (Key 30) makes contact with the top face of the bonnet (Key 20). See Figure 28.



Model 370 & 371 Control Valves

Operation, Parts, and Instruction Manual

MAINTENANCE (Continued)

For Double PTFE V-Ring and Graphite Packing:

Tighten the packing nuts (Key 33) evenly in an alternating pattern to the minimum recommended torque specifications listed in Table 3 on Page 23, continue tightening until leakage stops or the maximum torque specification is reached. If leakage continues after reaching the maximum recommended torque the packing will need to be replaced, do not tighten the packing past the maximum recommended torque as this will cause excessive packing friction.

For Live-Loaded Packing:

Refer to the Sliding Stem Live-Loaded Packing Manual (P-LLPS) for proper maintenance procedures.

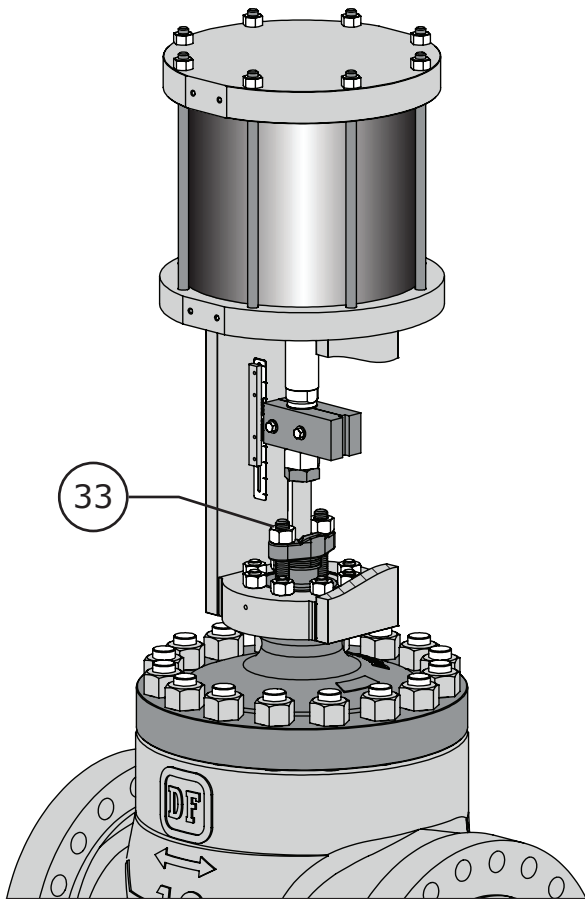

Figure 2 Maintenance - Packing Nut Tightening

ACTUATOR REMOVAL

Note: Actuator removal does not require that the valve be removed from the pipeline.

Tools Needed:

- Properly Rated Lifting Straps
- Lifting Device (Example: Crane)

Before You Begin:

- Read Safety Caution (Page 2).
- Use safe work practices and lock out procedures.
- Disconnect supply lines (air or gas), electric power, or control signal to the actuator. Sudden movement of actuator can cause damage or injury, make sure actuator will not operate.
- Vent any pneumatic actuator loading pressure and relieve any actuator spring preload if present.

- 1 Refer to the appropriate actuator instruction manual for more information regarding the actuator being removed.
- 2 If the valve has been removed from the pipeline, place the valve assembly on a flat work surface that can support the weight.
- 3 Before the actuator is removed, support the actuator using lifting hooks or straps rated to support the weight of the actuator.
- 4 Remove the stem connector (See Figure 3).
- 5 Loosen the jam nut and hex nut (Keys 42 & 43).
- 6 Remove the hex nuts (Key 23).
- 7 Lift the actuator from the valve.
- 8 Remove the jam nut and hex nut (Keys 42 & 43) from the valve stem (Key 5) if necessary.

Model 370 & 371 Control Valves

Operation, Parts, and Instruction Manual

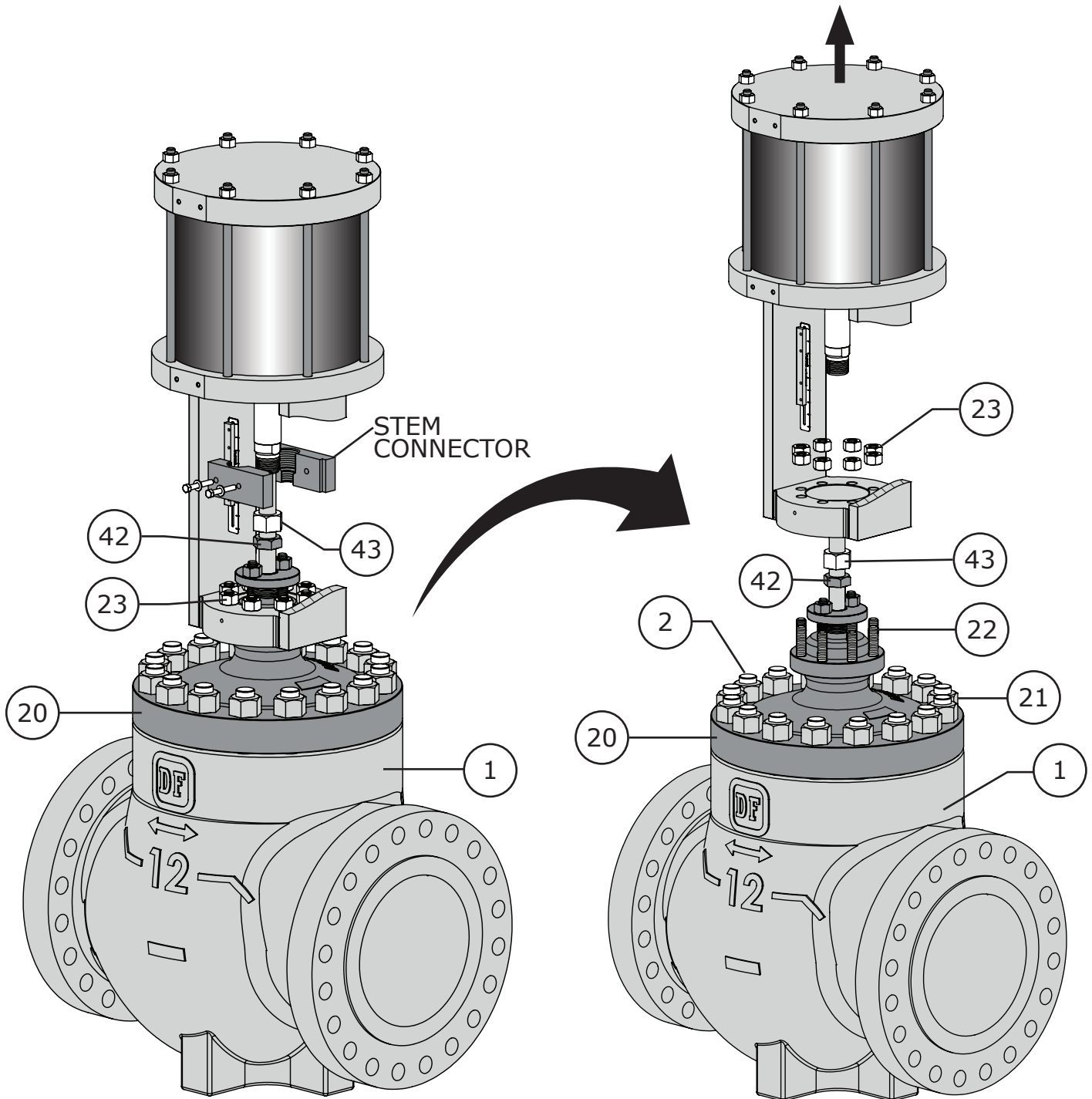

Figure 3 Actuator Removal - Stem Connector Disassembly

Figure 4 Actuator Removal



Model 370 & 371 Control Valves

Operation, Parts, and Instruction Manual

DISASSEMBLY

Before You Begin:

- Read Safety Caution (Page 2).
- Use safe work practices and lock out procedures.
- Remove the actuator from the valve (See Actuator Removal Instructions, Page 6).
- Relieve process pressure and drain the process fluid from up and down stream of valve.
- Be aware of potentially hazardous process material that may be present in-line and in-valve. Isolate the valve from process pressure. Use a bypass or block valve if necessary, or completely shut off the process.

PACKING REMOVAL

Special Tools Required:

- Mechanics Pick Set

NOTE: Packing box parts are easier to remove after the bonnet (Key 20) has been separated from the valve body (Key 1) and the valve stem (Key 5) has been removed. If the packing is all that needs to be removed, it is possible to extract packing box parts carefully using a mechanics pick set.

WARNING: Process medium and pressure may become stored in the packing, use caution when removing packing parts.

- 1 Determine what type of packing is in the valve (refer to Figures 30, 31, & 32). For live loaded packing assemblies, refer to the separate live loaded packing instruction manual (P-LLPS).
- 2 Remove the packing nuts (Key 33).
- 3 Remove the upper wiper (Key 31) if present.
- 4 Remove the packing follower (Key 30).
- 5 It is recommended to proceed to the Bonnet Removal section to continue with valve disassembly. If the packing is all that needs to be removed, remove the contents of the packing box (Keys 29, 28, 27, 26, & 25) using a mechanics pick set being careful not to damage the valve stem (Key 5) or wall of the packing box of the bonnet (Key 20). For packing reassembly refer to Packing Assembly section (Page 20).

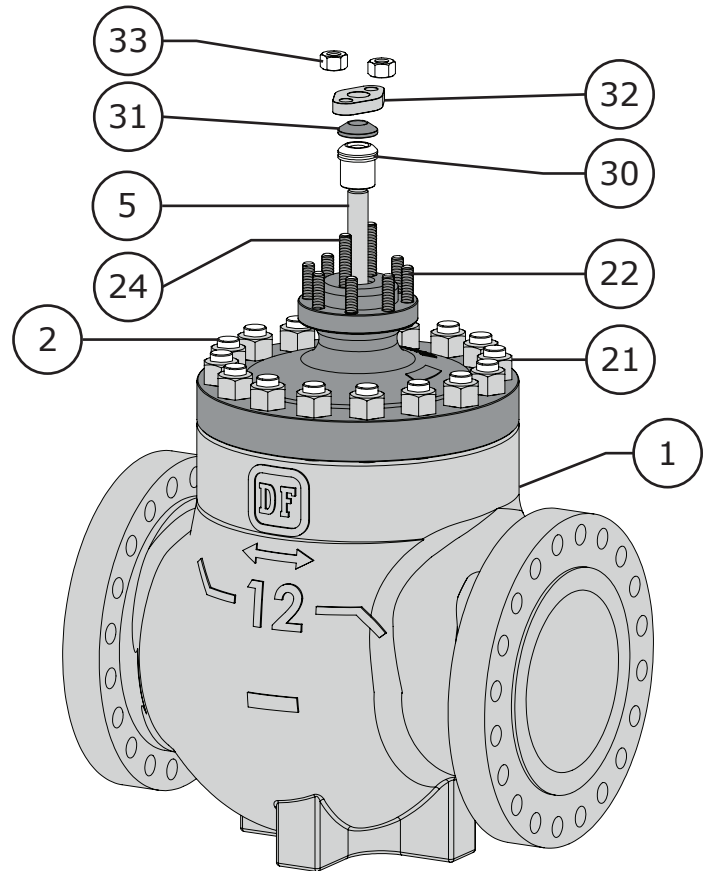

Figure 5 Packing Removal (Steps 1 - 4)

BONNET REMOVAL

WARNING: Process medium and pressure may be trapped inside the valve body (Key 1). Use caution when removing the valve bonnet (Key 20). Refer to Safety Caution on Page 2.

- 1 Loosen the bonnet nuts (Key 21) 1 full turn after the contact between the nuts and the top surface of the bonnet (Key 20) has been broken. Do not remove the bonnet nuts until any trapped process pressure has been vented. See Figure 6.
- 2 Break the contact between the valve body (Key 1) and the bonnet (Key 20), use a pry bar or blunt chisel to help with the separation if necessary.
- 3 If no process fluid or gas escapes from the body-to-bonnet joint proceed by completely removing the bonnet nuts (Key 21).

Model 370 & 371 Control Valves

Operation, Parts, and Instruction Manual

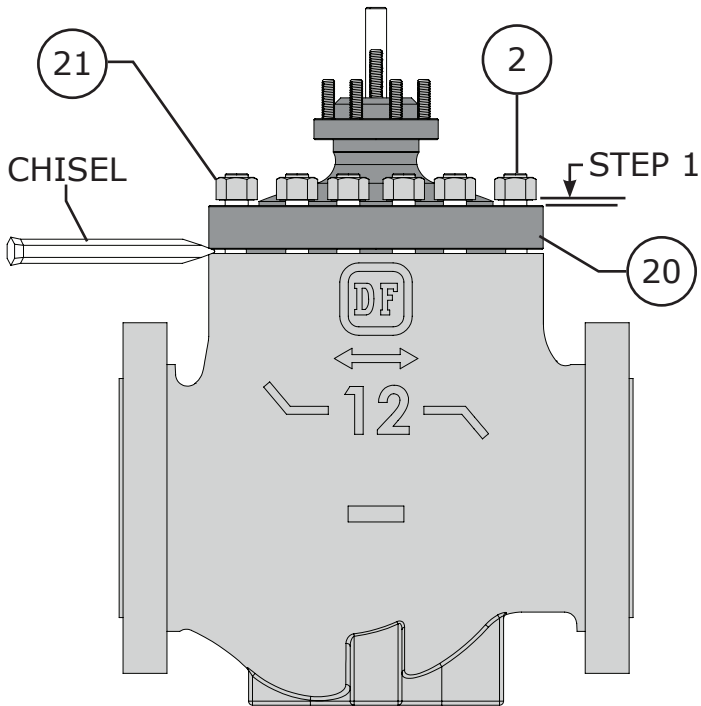

Figure 6 Bonnet Removal (Steps 1 - 2)

DISASSEMBLY (Continued)

BONNET REMOVAL (Continued)

- Carefully lift the bonnet (Key 20) from the valve body (Key 1), be sure that the valve stem (Key 5) and plug (Key 3) assembly do not drop from the bonnet and get damaged. Also, if the valve plug and stem assembly begin to lift when lifting the bonnet, it may be necessary to gently tap the stem from the bonnet using a rubber mallet as the bonnet is being lifted.

TRIM PARTS REMOVAL (Model 370)

Special Tools Required:

- Lifting bolts (eye bolts), 1/2"-13 NC, 2 required (Key Y)
- Remove the valve stem (Key 5) / valve plug (Key 3) assembly from the valve body (Key 1). See Plug Seal Removal section for instructions for disassembling Model 370 and 371 plug seals.
 - Remove the bonnet gasket (Key 19).

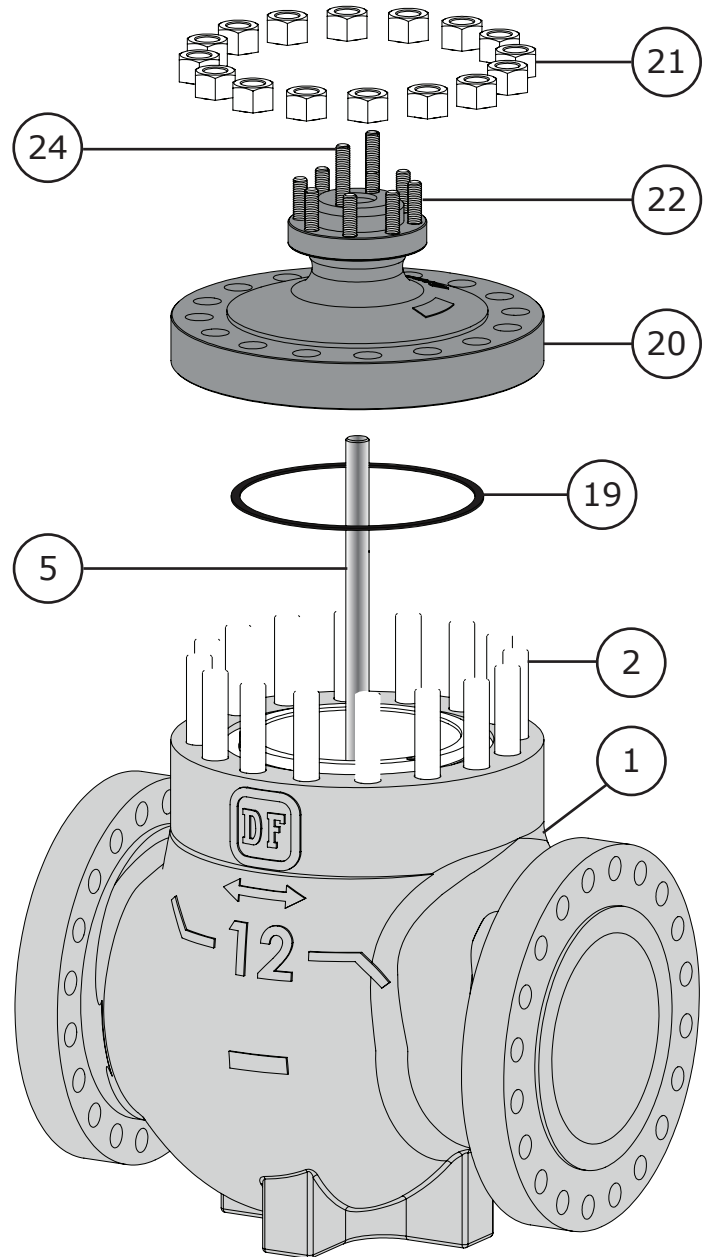

Figure 7 Bonnet Removal (Steps 3 - 4)



Model 370 & 371 Control Valves

Operation, Parts, and Instruction Manual

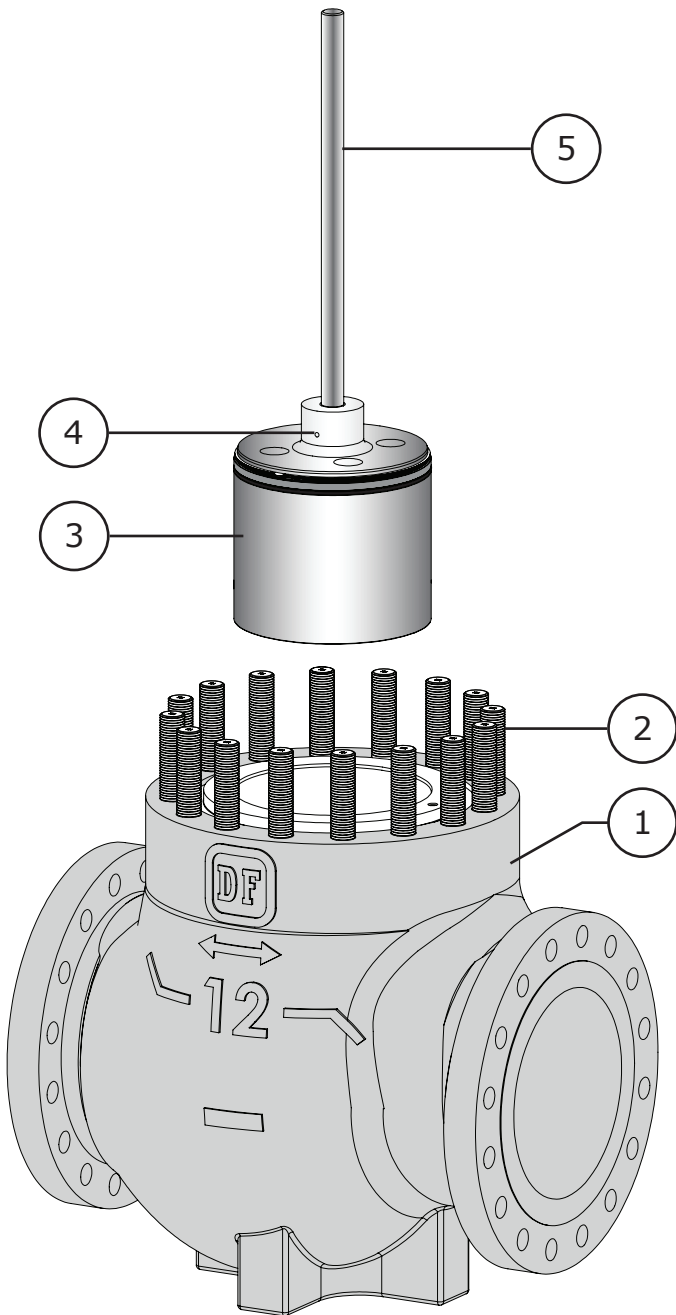

Figure 8 Trim Parts Removal (Step 1)

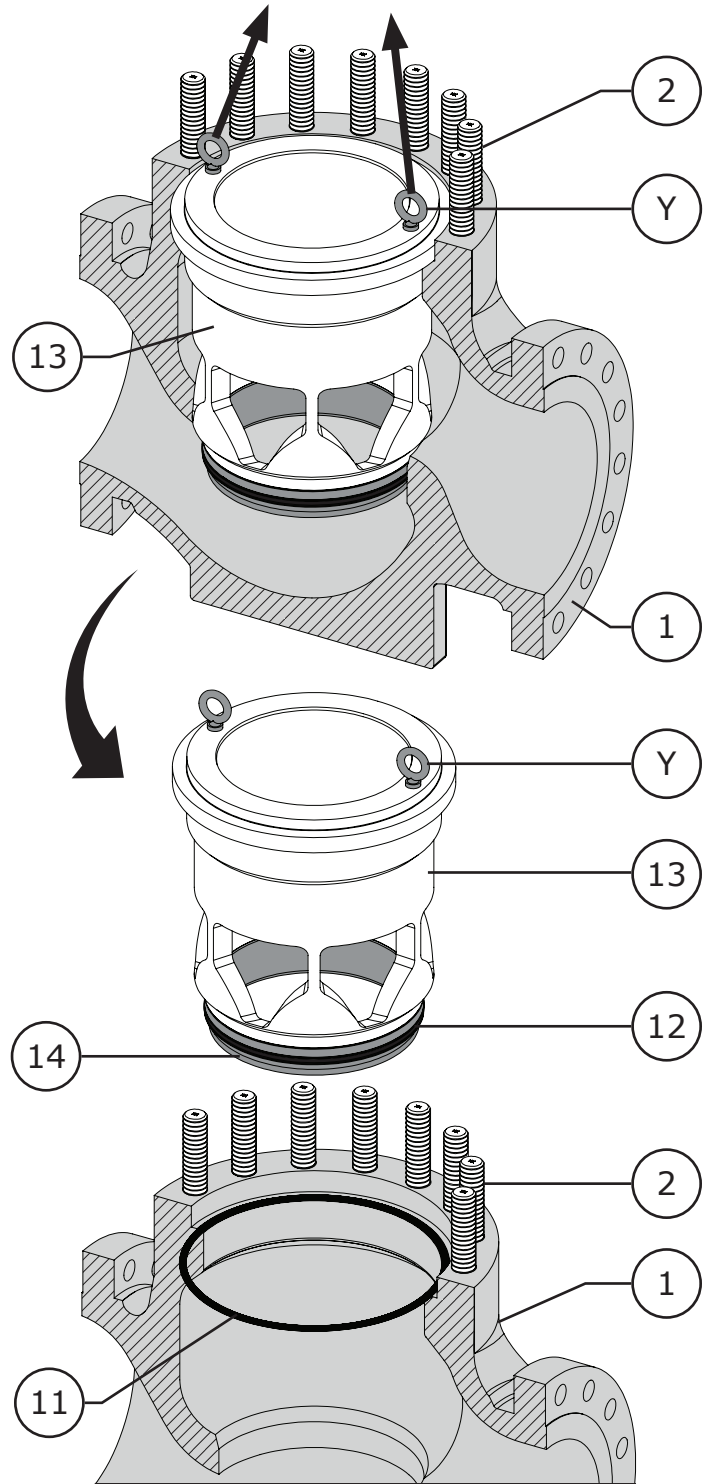

Figure 9 Trim Parts Removal (Steps 3 & 4)

Model 370 & 371 Control Valves

Operation, Parts, and Instruction Manual



DISASSEMBLY (Continued)

TRIM PARTS REMOVAL (Model 370) (Continued)

- 3 The cage (Key 13) is equipped with tapped holes for the installation of lifting bolts. Using lifting bolts (Key Y), carefully remove the cage/seat ring assembly (Keys 12, 13, & 14). Refer to Figure 9.
- 4 Remove the cage gasket (Key 11).
- 5 The seat ring (Key 14) and cage (Key 13) are threaded together and the seat ring is tack welded to the cage. To ensure quality fit and tolerances, it is not recommended that the seat ring and cage be separated

- 6 Remove the spring loaded seal ring (Key 12) from the seat ring (Key 14). Spring loaded seals should not be reused.
- 7 Clean and inspect all parts for damage, especially gasket seal surfaces. Replace all damaged parts and gaskets with new parts as necessary, gaskets cannot be reused.
- 8 Clean and inspect all parts for damage, especially sealing surfaces. Replace all damaged parts and seal rings with new parts as necessary, seal rings cannot be reused.

TRIM PARTS REMOVAL (Model 371)

Special Tools Required:

- Lifting bolts (eye bolts), 1/2"-13 NC, 2 required (Key Y).

- 1 Remove the valve stem (Key 5) / valve plug (Key 3) assembly from the valve body (Key 1). Refer to the Plug Seal Removal section for instructions for disassembling Model 370 and 371 plug seals.
- 2 Remove the bonnet gasket (Key 19).
- 3 The cage (Key 18) is equipped with tapped holes to install lifting bolts. Using lifting bolts (Key Y), carefully remove the cage. Refer to Figure 11.
- 4 Remove the cage gasket (Key 11).
- 5 Remove the seat ring cap screws (Key 17).
- 6 The Model 371 seat ring (Key 16) is equipped with tapped holes for the installation of lifting bolts. Using the lifting bolts (Key Y), carefully remove the seat ring from inside the valve body (Key 1).
- 7 Remove the seat ring gasket (Key 15).
- 8 Clean and inspect all parts for damage, especially gasket seal surfaces. Replace all damaged parts and gaskets with new parts as necessary, gaskets cannot be reused.

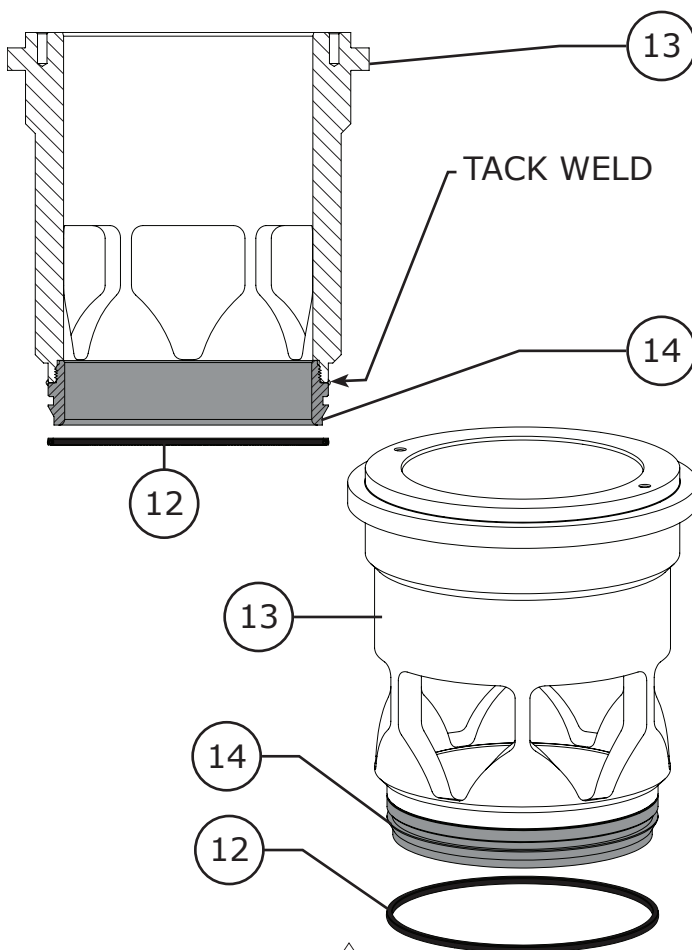

Figure 10 Trim Parts Removal (Steps 5 & 6)



Model 370 & 371 Control Valves

Operation, Parts, and Instruction Manual

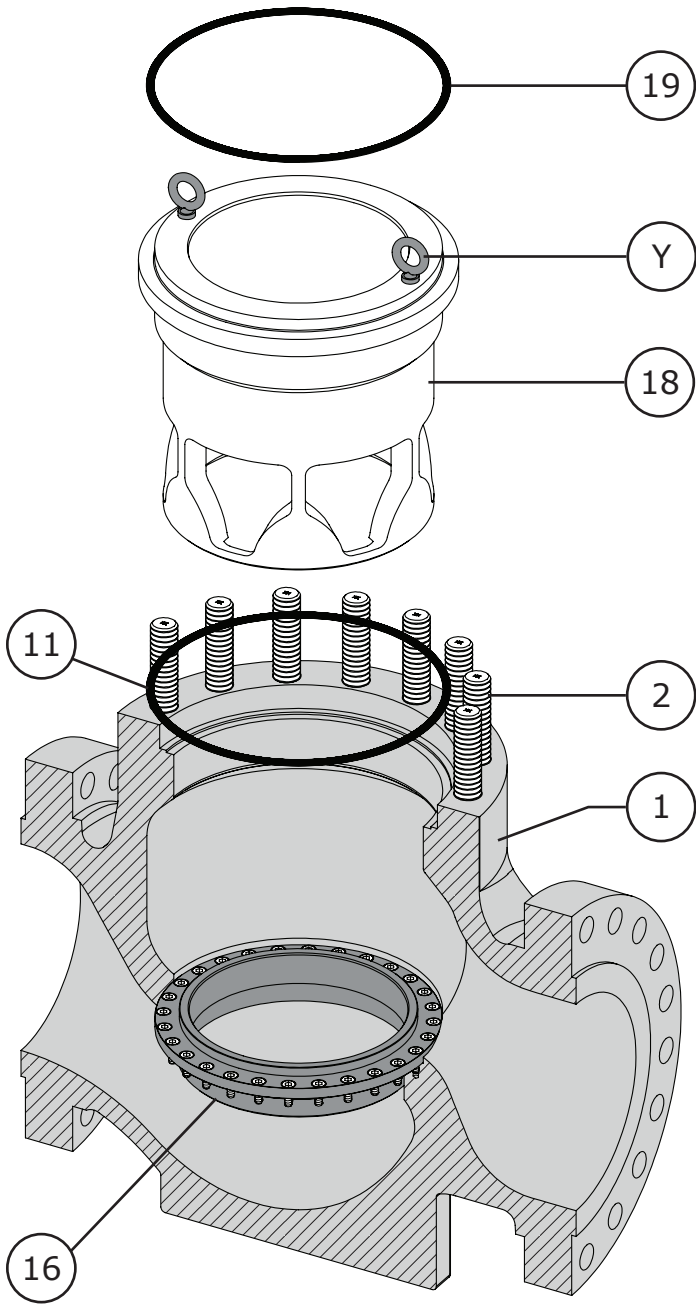

Figure 11 Trim Parts Removal - 371 (Steps 2 - 3)

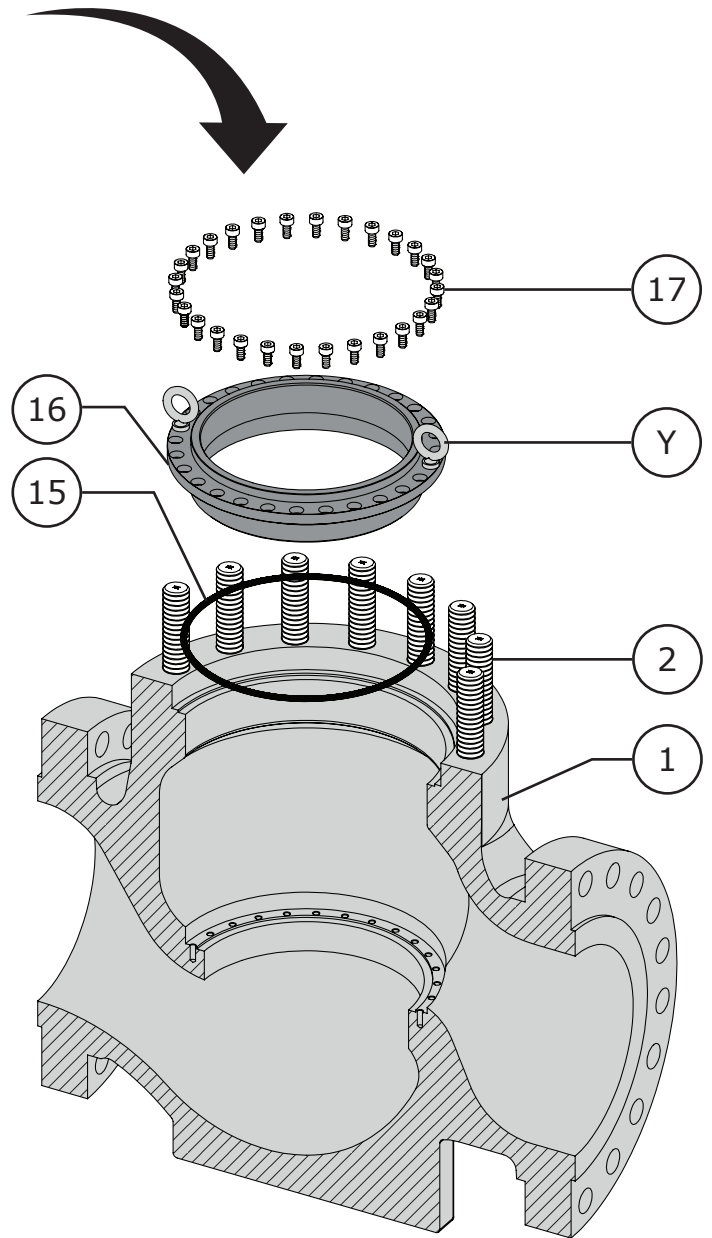

Figure 12 Trim Parts Removal - 371 (Steps 5 - 7)

Model 370 & 371 Control Valves

Operation, Parts, and Instruction Manual



DISASSEMBLY (Continued)

PLUG SEAL REMOVAL

For Model 370 Valves (See Figure 13):

- 1 Carefully remove the retaining ring (Key 8) from the plug groove, a pick set or flat screw driver may be required.
- 2 Remove the backup ring (Key 7).
- 3 Remove the anti-extrusion ring (Key 9). The anti-extrusion ring is only included in 370 valve assemblies rated for over 450°F (232°C). Anti-extrusion rings have two pieces.
- 4 Remove the seal ring (Key 6).

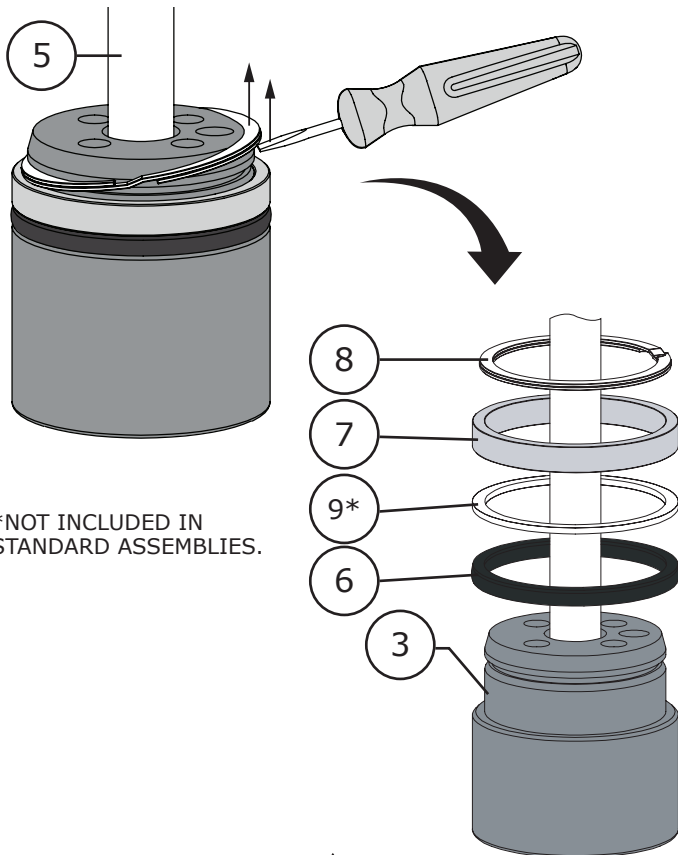

*NOT INCLUDED IN STANDARD ASSEMBLIES.

Figure 13 Plug Seal Removal for Model 370 Valves

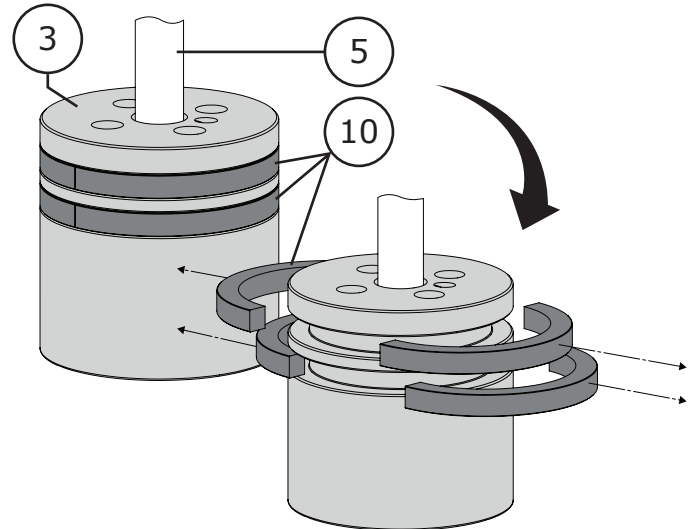

Figure 14 Model 371 Piston Ring Removal

For Model 371 Valves (See Figure 14):

- 1 Remove the piston rings (Key 10). **NOTE:** Piston rings are broken in half and can be easily pulled apart.

For All Models:

Clean and inspect all parts for damage, especially the stem (Key 5) and plug (Key 3) surfaces. Minor scratches can be buffed or lapped out, major scratches (scratches that will stop a finger nail) will need to be machined or replaced. Replace all damaged parts and soft parts with new parts.

PACKING PARTS REMOVAL

WARNING: Compressed gasses could be trapped between packing rings.

- 1 Using a blunt or rounded tool or rod, carefully tap the packing parts out of the packing bore of the bonnet (Key 20). A mechanic's pick set can also be used to pull packing parts from the bore.
- 2 Clean and inspect the bonnet for damage, pay particular attention to the packing bore surface and the gasket sealing surface. Replace or repair the bonnet as necessary. Metal packing parts can be reused if they are not damaged, all other packing parts should be replaced.



Model 370 & 371 Control Valves

Operation, Parts, and Instruction Manual

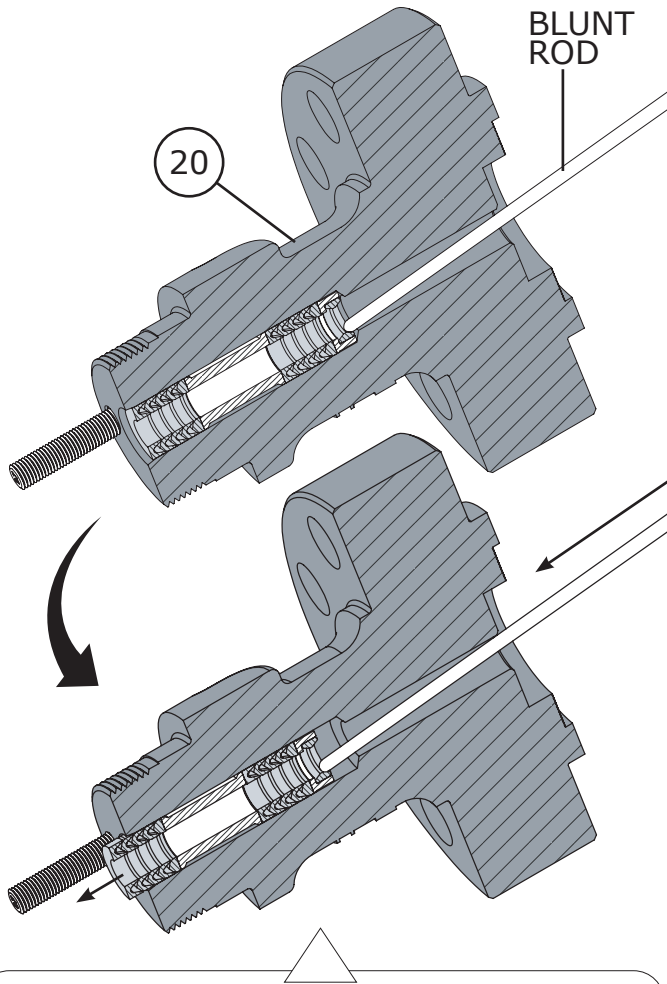

Figure 15 Packing Parts Removal (Step 1)

ASSEMBLY

Before You Begin:

- Read Safety Caution (Page 2).
- Use safe work practices and lock out procedures.
- Clean and inspect all parts.
- Replace or repair damaged parts. Replace all soft parts (Seals, o-rings, gaskets, live loaded packing).

Lubricants Required:

- Anti-Seize Compound (Key A)
- Silicone-based O-Ring Compound (Key B)
- White Petroleum Grease (Key C)

STUD INSTALLATION

- 1 If the studs (Key 2) were replaced, removed, or never installed, apply anti-seize compound (Key A) to the threads of the end of the stud without a material stamp.
- 2 Thread the studs (Key 2) into the valve body (Key 1) anti-seize coated end first, until they are completely threaded into the valve body.

PLUG SEAL ASSEMBLY

For Model 370 Valves:

- 1 Apply white petroleum grease (Key C) to the surface of the seal ring (Key 6).
- 2 Install the seal ring (Key 6) onto the valve plug (Key 3), refer to Figure 16 for proper seal ring orientation.
- 3 If required, apply white petroleum grease (Key C) to the anti-extrusion ring (Key 9) and install the anti-extrusion ring on to the valve plug as shown in Figure 17. **NOTE:** Anti-extrusion rings are only used for valve assemblies rated to exceed 450°F (232°C).
- 4 Apply white petroleum grease (Key C) to the backup ring (Key 7) and install the backup ring onto the valve plug (Key 3).
- 5 Install the retaining ring (Key 8) into the retaining ring groove on the valve plug (Key 3).
- 6 Allow time for the seal ring material to shrink back to its original size after being stretched over the valve plug before installing the plug assembly into the cage (Key 13).

For Model 371 Valves:

NOTE: Replacement piston rings (Key 10) come in one piece. Before installation it is necessary to break the piston ring into two pieces. Do not saw or cut the piston rings. Use caution when breaking piston rings as they can be easily damaged.

Piston Ring Vise Break Method:

Piston rings (Key 10) can be broken into two pieces using a vise with smooth jaws or jaw softeners. Refer to Figure 18.

Special Tools Required:

- Vise
- Electrical Tape

- 1 A Wrap electrical tape once around the outside diameter of the piston ring (Key 10). Electrical tape will help contain the piston ring while it is being broken. See Figure 18.
- 2 Place the piston ring into the jaws of the vise as shown in Figure 19.

Model 370 & 371 Control Valves

Operation, Parts, and Instruction Manual

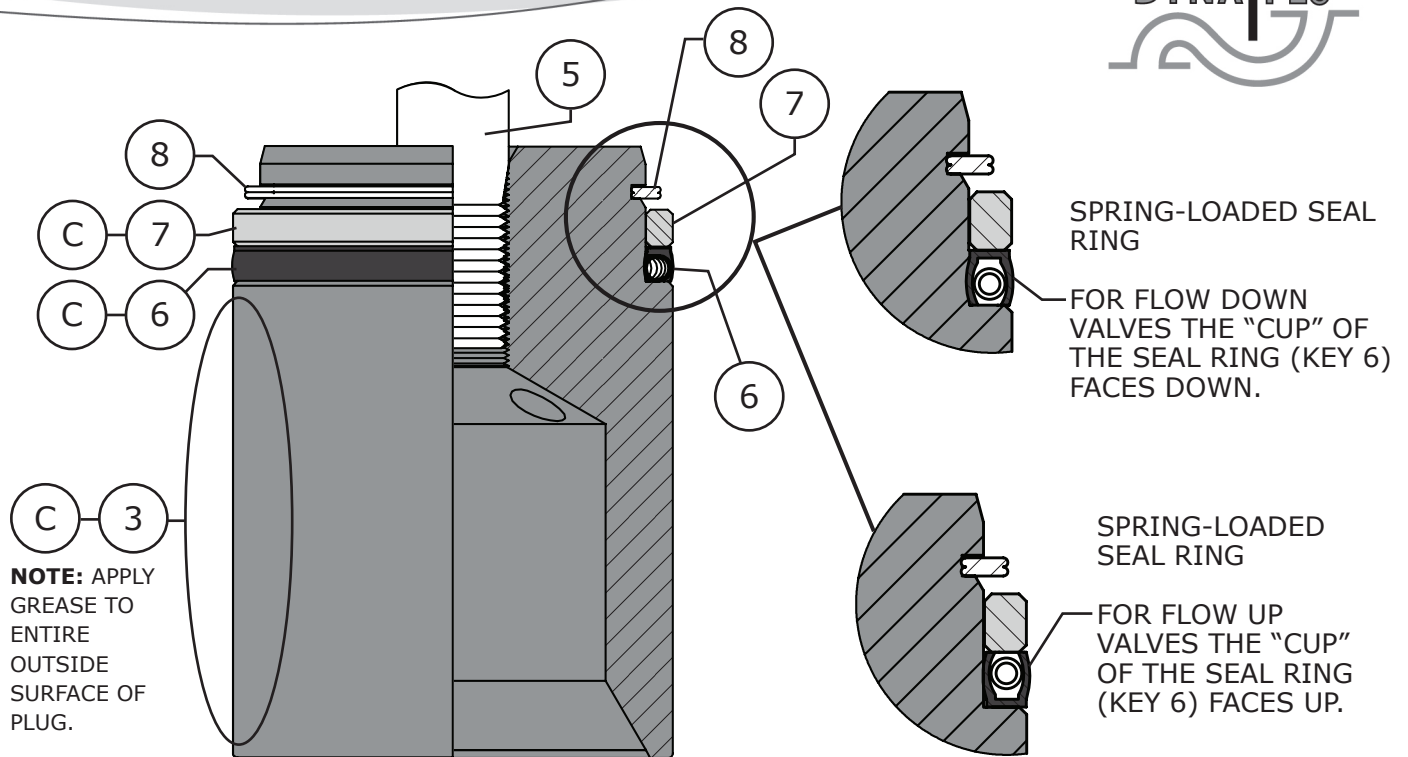

Figure 16 Model 370 Plug Seal Standard Assembly

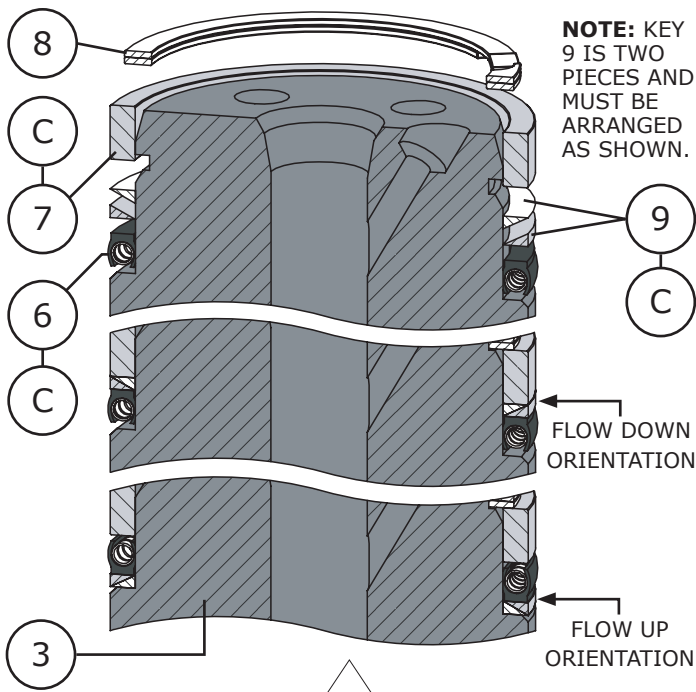

Figure 17 Plug Seal Assembly with Anti-Extrusion Ring

ASSEMBLY (Continued)

PLUG SEAL ASSEMBLY (Continued)

For Model 371 Valves (Continued):

- 3 Slowly compress the piston ring in the vise until the ring snaps on both sides. If one side of the piston ring snaps first, continue compressing the piston ring until the other side snaps as well.

Piston Ring Scoring Break Method:

If no vise is available, piston rings (Key 10) can be scored with a knife and broken over a hard surface. Do not saw or cut the piston rings in half.

- 1 Wrap electrical tape once around the outside diameter of the piston ring (Key 10). Electrical tape will help contain the piston ring while it is being broken. See Figure 18.
- 2 Score (do not cut) the top surface of the piston ring.
- 3 Place half of the piston ring over the edge of a hard surface (such as a table edge) so that the score marks are in a parallel line with the edge of the hard surface.
- 4 Apply downward pressure to both sides of the piston ring until it snaps in half.
- 5 Remove the electrical tape. Install each half of the broken piston ring into the piston ring groove in the valve plug (Key 10). See Figure 20.



Model 370 & 371 Control Valves

Operation, Parts, and Instruction Manual



Figure 18 Piston Ring Assembly for Model 371 Valves (Step 1)

Figure 19 Piston Ring Assembly for Model 371 Valves (Step 2)

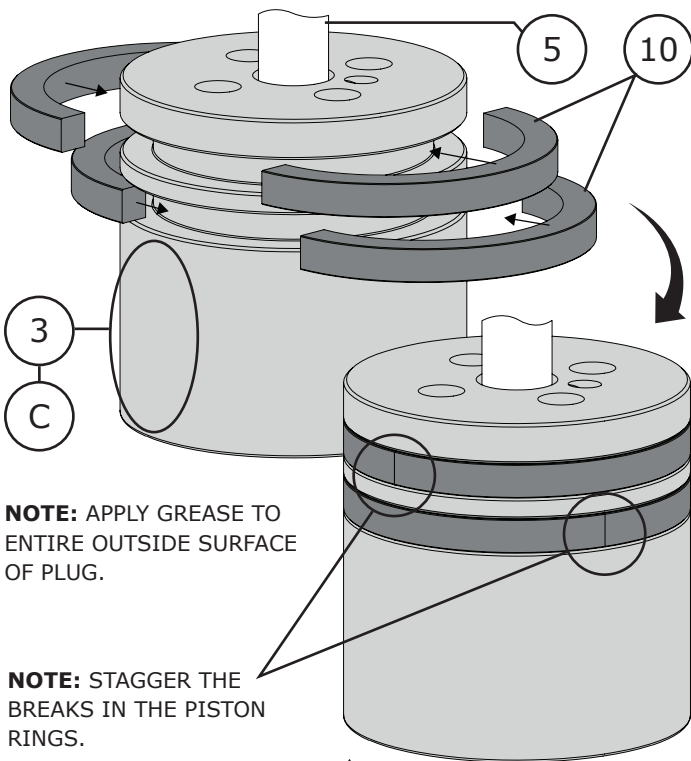

Figure 20 371 Piston Ring Installation

ASSEMBLY (Continued)

TRIM PARTS ASSEMBLY (Model 370)

Special Tools Required:

- Lifting bolts (eye bolts), 1/2"-13 NC, 2 required (Key Y).

NOTE: Spiral wound gaskets (Keys 11 & 19) make their seal by being crushed and cannot be reused.

- 1 Apply white petroleum grease (Key B) to the outside of the spring loaded seal ring (Key 12).
- 2 Carefully work the seal ring (Key 12) over the seat ring (Key 14) until the seal ring rests in the groove on the seat ring. The seal ring should be orientated the same direction as the seal ring used on the valve plug (Key 3) from the Plug Seal Assembly section. Refer to Figure 16 for proper seal ring orientations. Let the spring loaded seal ring rest until the seal ring shrinks back into shape after being stretched over the seat ring.
- 3 Apply anti-seize compound (Key A) to the top and bottom surfaces of the cage gasket (Key 11). Install the cage gasket as shown in Figure 22.

Model 370 & 371 Control Valves

Operation, Parts, and Instruction Manual

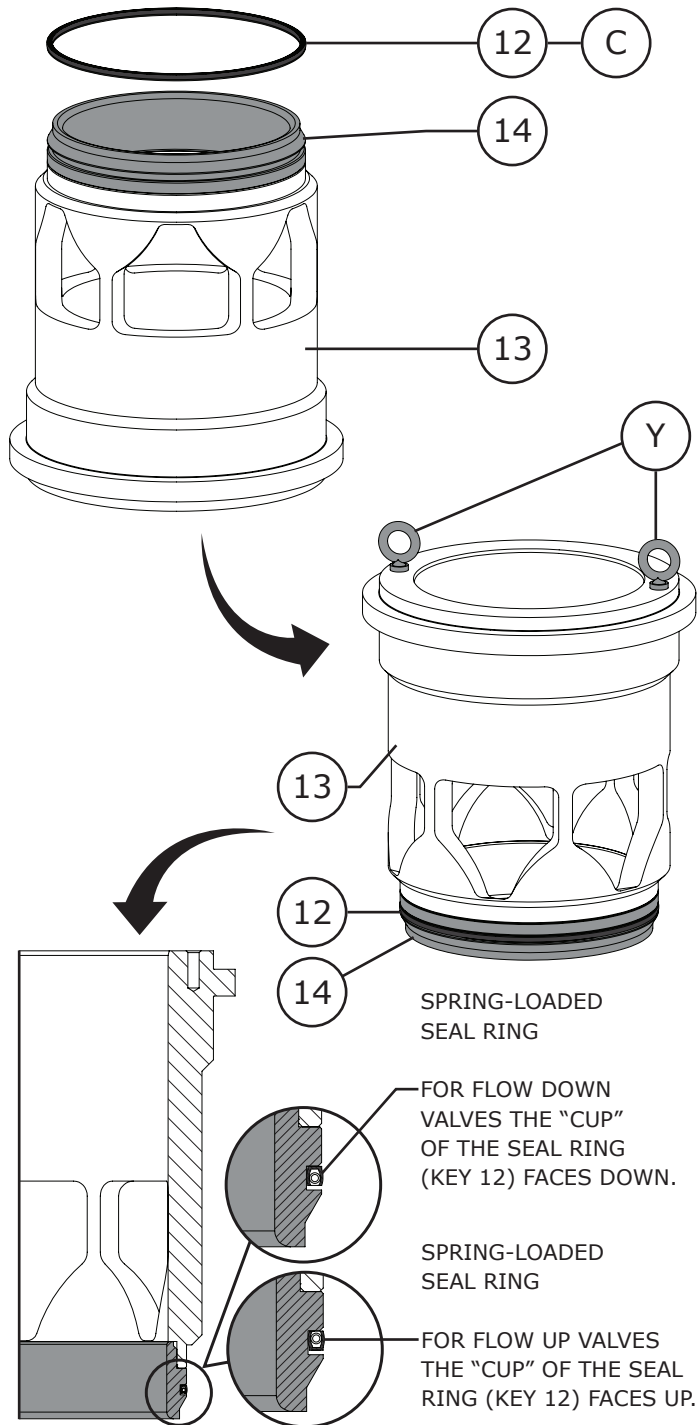

Figure 21 Trim Parts Assembly - 370 (Steps 1 - 2)

ASSEMBLY (Continued)

TRIM PARTS ASSEMBLY (Model 370) (Continued)

- 4 Install lifting bolts (Key Y) into the tapped holes of the cage (Key 13). Using the lifting bolts, carefully lift and lower the cage/seal ring assembly (Keys 12, 13, & 14) into the valve body as shown in Figure 22. Remove the lifting bolts once cage/seal ring is in position.
- 5 Apply anti-seize compound to the top and bottom surfaces of the bonnet gasket (Key 19). Install the bonnet gasket as shown in Figure 22.

TRIM PARTS ASSEMBLY (Model 371)

Special Tools Required:

- Lifting bolts (eye bolts), 1/2"-13 NC, 2 required (Key Y).

NOTE: Spiral wound gaskets (Keys 11, 15, & 19) make their seal by being crushed and cannot be reused.

- 1 Apply anti-seize compound (Key A) to the top and bottom surfaces of the seat ring gasket (Key 15). Install the seat ring gasket as shown in Figure 23.
- 2 Install lifting bolts (Key Y) to the tapped holes of the seat ring (Key 16). Using the lifting bolts, carefully lift and lower the seat ring into the valve body as shown in Figure 23. Remove the lifting bolts once the seat ring is in position.
- 3 Apply anti-seize compound (Key A) to the threads of the cap screws (Key 17), thread the cap screws through the seat ring and into the valve body (Key 1). Torque the cap screws evenly in a crisscross pattern in increments of 10 lbf-ft. until the final torque value listed in Table 4 is reached.
- 4 Apply anti-seize compound (Key A) to the top and bottom surfaces of the cage gasket (Key 11). Install the cage gasket as shown in Figure 23.
- 5 Install lifting bolts (Key Y) into the tapped holes of the cage (Key 18). Using the lifting bolts, carefully lift and lower the cage into the valve body (Key 1) as shown in Figure 23. Remove the lifting bolts once the cage is in position.
- 6 Apply anti-seize compound to the top and bottom surfaces of the bonnet gasket (Key 19). Install the gasket as shown in Figure 23.

Model 370 & 371 Control Valves

Operation, Parts, and Instruction Manual

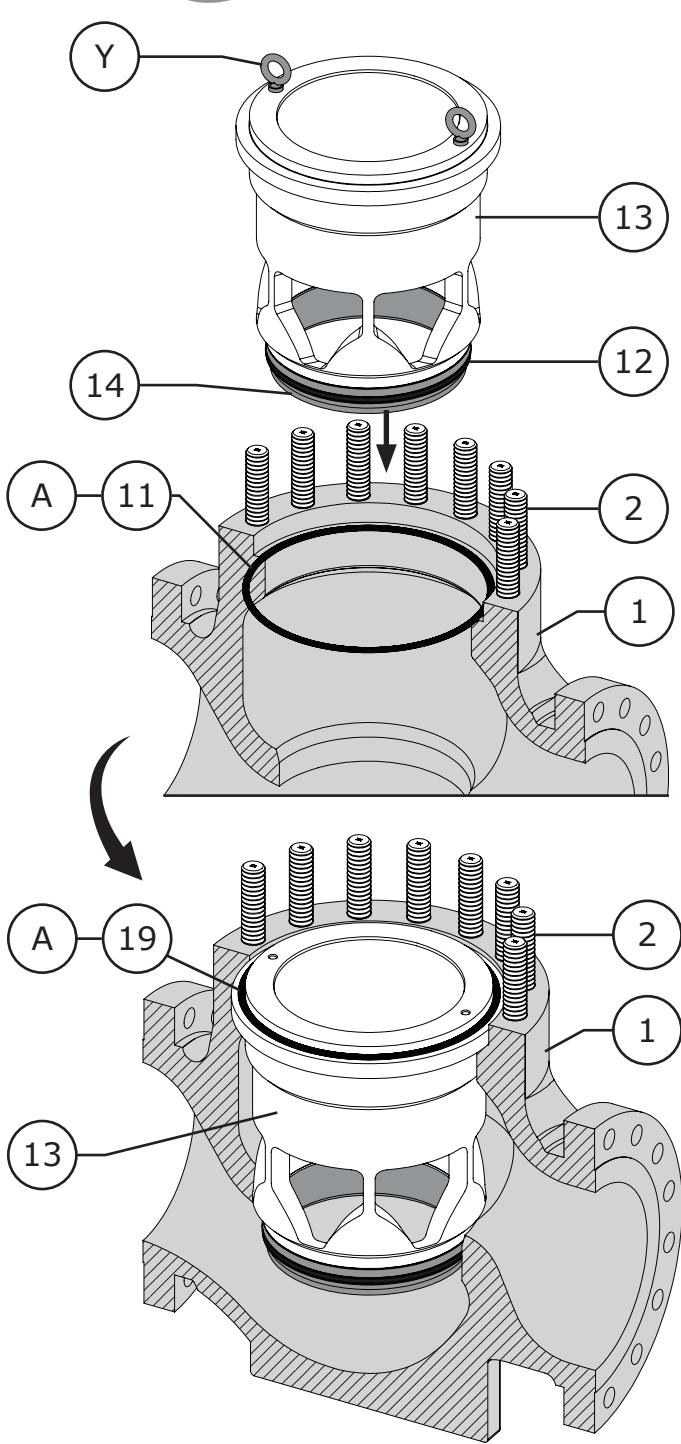

Figure 22 Trim Parts Assembly - 370 (Steps 3 - 5)

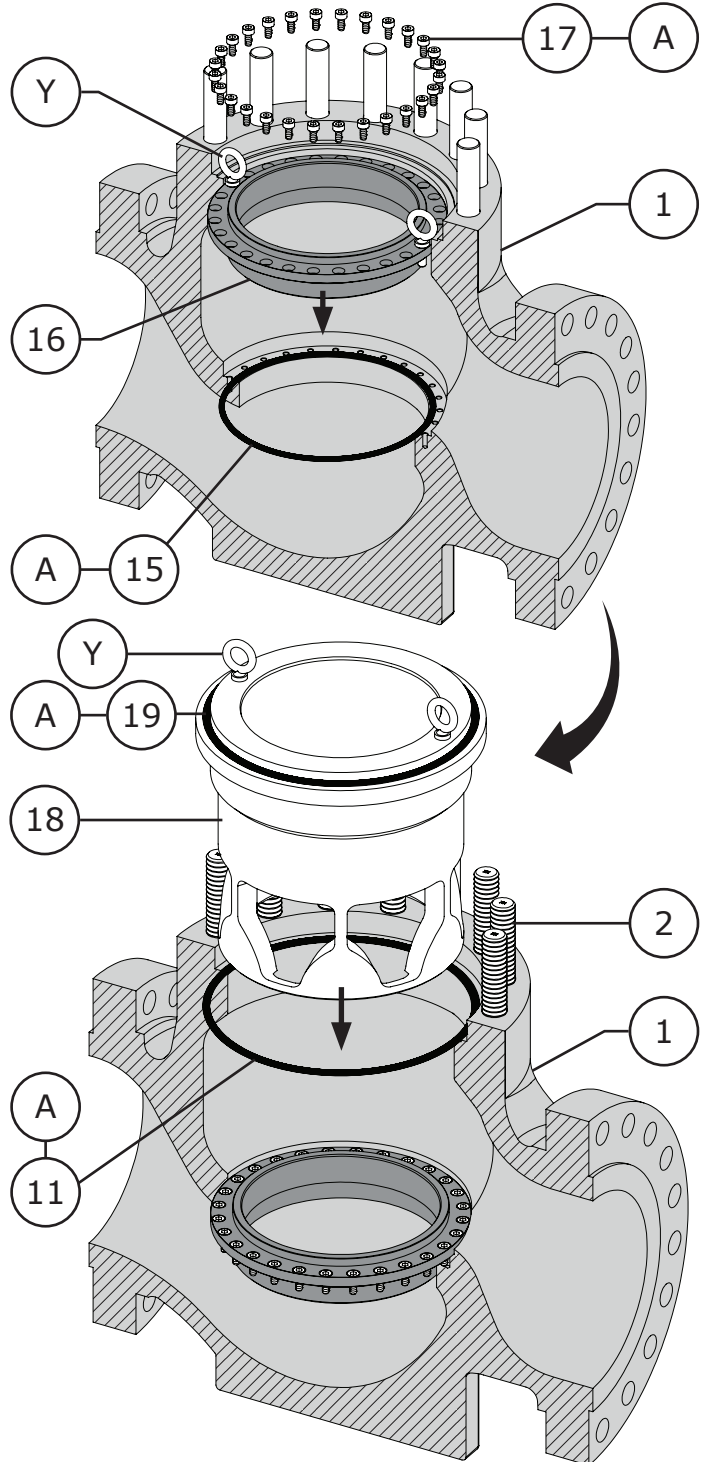

Figure 23 Trim Parts Assembly - 371 (Steps 1 - 6)

Model 370 & 371 Control Valves

Operation, Parts, and Instruction Manual



ASSEMBLY (Continued)

BONNET INSTALLATION

Before You Begin:

- Read Safety Caution (Page 2).
- Clean and inspect all parts.
- Replace or repair damaged parts. Replace all soft parts .

- 1 Install the plug/stem assembly (Key 3, 4, & 5) that was assembled in the Plug Seal Assembly section (Page 14). Refer to Figure 25.
- 2 Carefully lift and lower the valve bonnet (Key 20) into place over the valve stem (Key 5). Be careful not to damage either the stem, bonnet, or valve body (Key 1).
- 3 Apply anti-seize compound (Key A) to the threads of the bonnet studs (Key 2). Thread the bonnet nuts (Key 21) onto the bonnet studs until hand tight.
- 4 Stroke the valve a few times to center the valve trim.
- 5 It may help to install the packing follower (Key 30) during bonnet installation to act as a visual cue to indicate areas of over or under tightening. If the packing follower begins to bind or appear lop-sided, this is an indication that torquing procedures in Steps 6 & 7 need to be altered to correct areas that need more tightening or less. The packing follower should remain centered during the torquing process.

- 6 Follow proper body-to- bonnet bolting procedures. Begin to torque the bonnets nuts (Key 21) $\frac{1}{4}$ of the torque value listed in Table 2, torque the nuts in a crisscross pattern as shown in Figure 24. Hot torquing the valve nuts is not recommended.
- 7 Continue tightening the bonnet nuts (Key 21), increasing the torque by $\frac{1}{4}$ of the final torque specification each round of tightening while repeating the crisscross pattern until the final torque specification is reached.

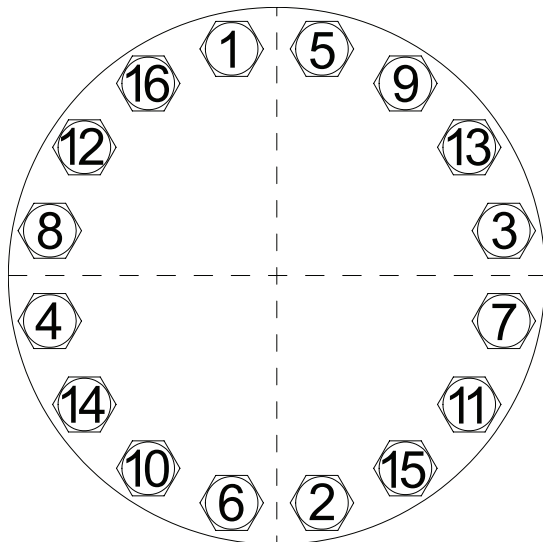

Figure 24 Bonnet Bolt Tightening Pattern

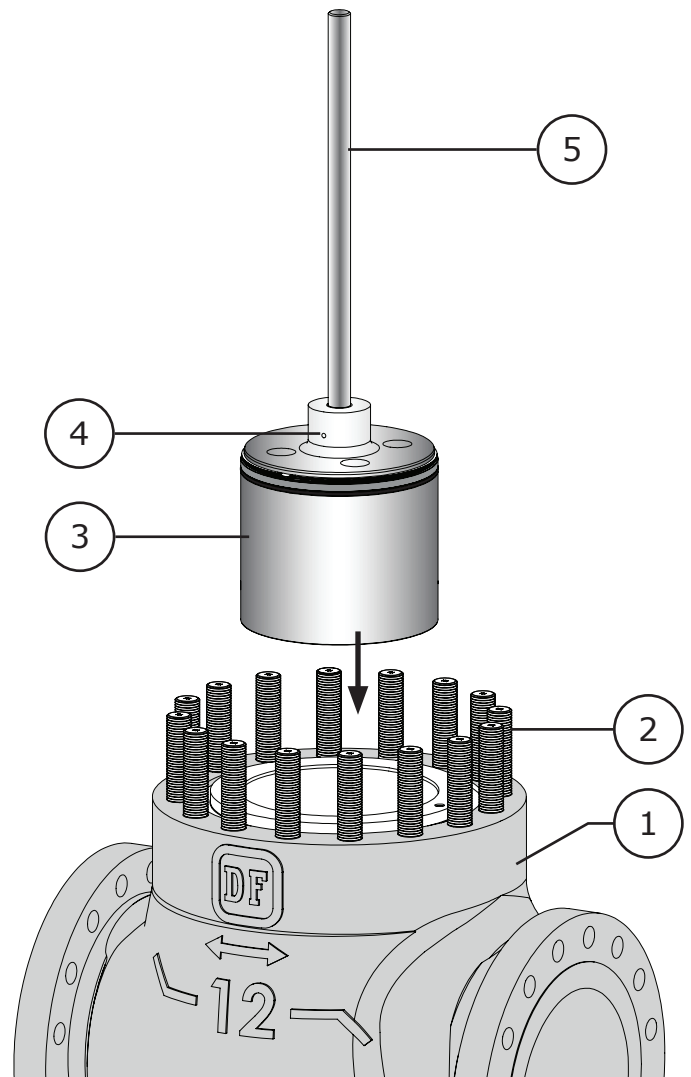

Figure 25 Bonnet Installation (Step 1)



Model 370 & 371 Control Valves

Operation, Parts, and Instruction Manual

ASSEMBLY (Continued)

BONNET INSTALLATION (Continued)

- 8** Double check the tightness of all nuts by torquing the nuts to the final torque specification again after the final torque valve was reached.

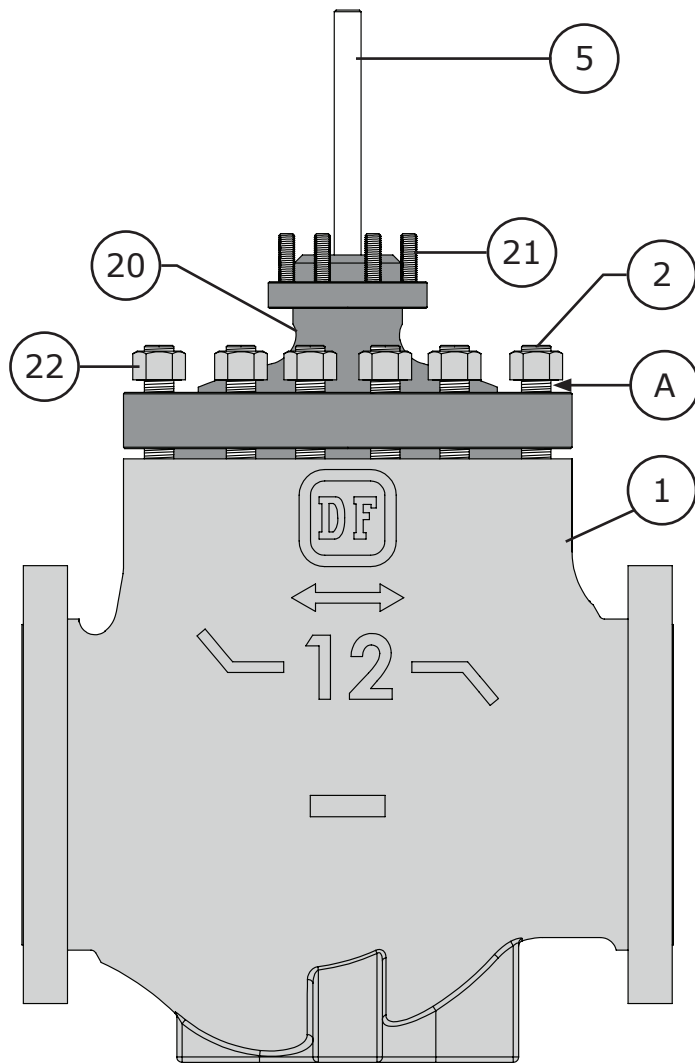

Figure 26 Bonnet Installation

PACKING INSTALLATION

For Live Loaded packing instructions see the Live Loaded Sliding Stem Packing Manual (Part Number P-LLPS). For other packing arrangements see Figures 28, 30, 31, & 32.

Lubricants Required:

- Anti-seize compound (Key A)
- White petroleum grease (Key B)
- Silicone-based o-ring compound (Key C)

NOTE: To prevent trapping air between packing during installation, it is recommended that packing rings be installed one at a time using the packing follower (Key 30) to push the packing rings in place. Do not force packing rings below the chamfer of the packing bore before adding another ring, packing rings should only be pushed down the thickness of the added ring. Refer to Figure 27.

- 1** If the packing studs (Key 24) were replaced, removed, or never installed, apply anti-seize compound (Key A) to the threads of the stud end without a material stamp.
- 2** Thread the studs (Key 24) into the valve bonnet (Key 20) anti-seize coated end first until they are completely threaded into the bonnet.

For Single Style (Spring-Loaded) Packing:

- 1** Apply silicone-based o-ring compound (Key C) to the lower stem wiper (Key 25). Insert the lower stem wiper into the packing box ring (Key 26). Insert the packing box ring into the packing bore of the valve bonnet (Key 20).
- 2** Install the packing spring (Key 27).
- 3** Install the special washer (Key 28).
- 4** Apply silicone-based o-ring compound (Key C) to the PTFE packing rings (Key 29). Install the packing rings one ring at a time (as shown in Figure 27) in the proper order and orientation as shown in Figure 28. **WARNING:** For oxygen service do not apply silicone-based o-ring compound, silicone-based compound in oxygen service applications can cause an explosion.
- 5** Install the packing follower (Key 30).
- 6** Install the upper stem wiper (Key 31).

Model 370 & 371 Control Valves

Operation, Parts, and Instruction Manual

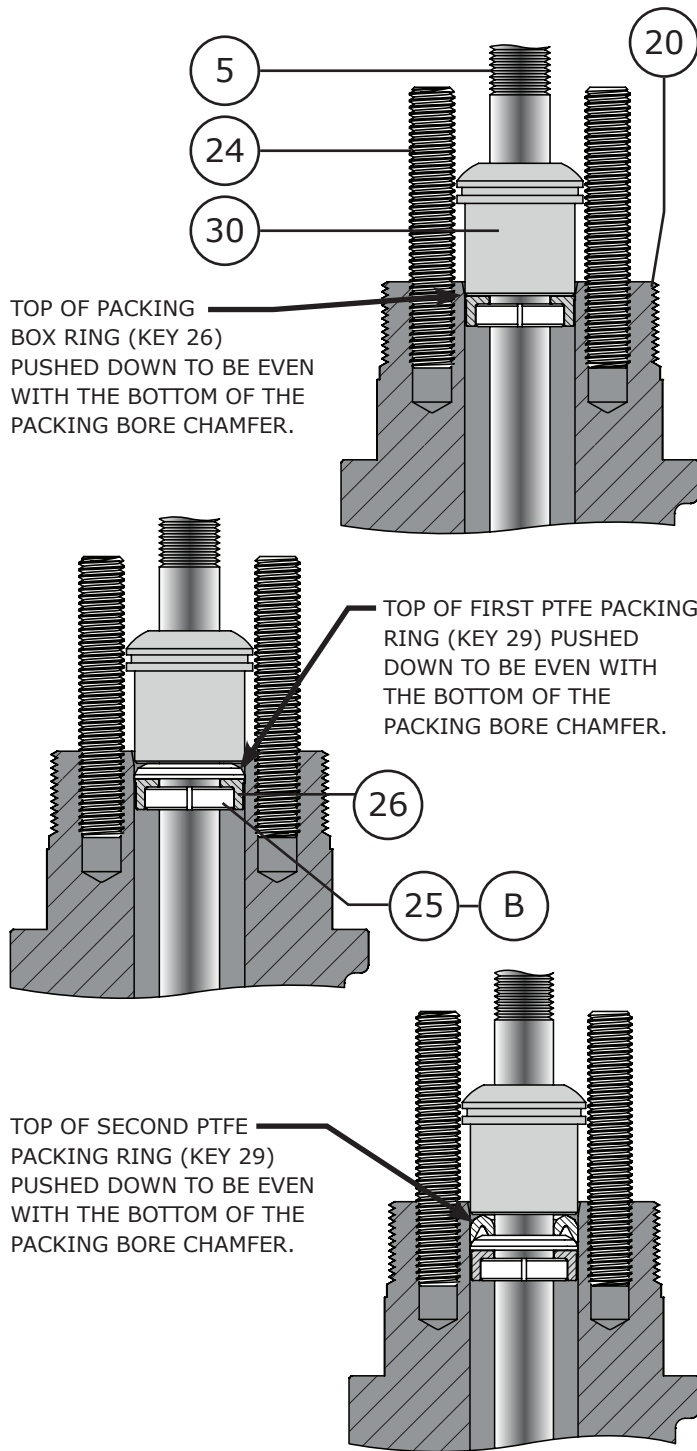

Figure 27 Proper Packing Ring Installation

ASSEMBLY (Continued)

PACKING INSTALLATION (Continued)

For Single Style (Spring-Loaded) Packing (Continued):

- 7 Install the packing flange (Key 32).
- 8 Apply anti-seize compound (Key A) to the top threads of the packing studs (Key 24). Thread the packing nuts (Key 33) onto the threads of the packing studs, tighten the packing nuts evenly in an alternating pattern until the shoulder of the packing follower (Key 30) makes contact with the bonnet (Key 20). Refer to Figure 28.

For Double Style PTFE Packing:

- 1 Apply silicone-based o-ring compound (Key C) to the lower stem wiper (Key 25). Insert the lower stem wiper into the packing box ring (Key 26). Insert the packing box ring into the packing bore of the valve bonnet (Key 20).
- 2 Apply silicone-based o-ring compound (Key C) to the first set of packing rings (Key 29). Install the packing rings one ring at a time (as shown in Figure 27) in the proper order and orientation as shown in Figure 30. **WARNING:** For oxygen service do not apply silicone-based o-ring compound, silicone-based compounds in oxygen service applications can cause an explosion.
- 3 Install the lantern ring (Key 34).
- 4 Apply silicone-based o-ring compound (Key C) to the second set of packing rings (Key 29). Install the packing rings one ring at a time (as shown in Figure 27) in the proper order and orientation as shown in Figure 30. **WARNING:** For oxygen service do not apply silicone-based o-ring compound, silicone-based compounds in oxygen service applications can cause an explosion.
- 5 Install the packing follower (Key 30).
- 6 Install the upper stem wiper (Key 31).
- 7 Install the packing flange (Key 32).
- 8 Apply anti-seize compound (Key A) to the top threads of the packing studs (Key 24).



Model 370 & 371 Control Valves

Operation, Parts, and Instruction Manual

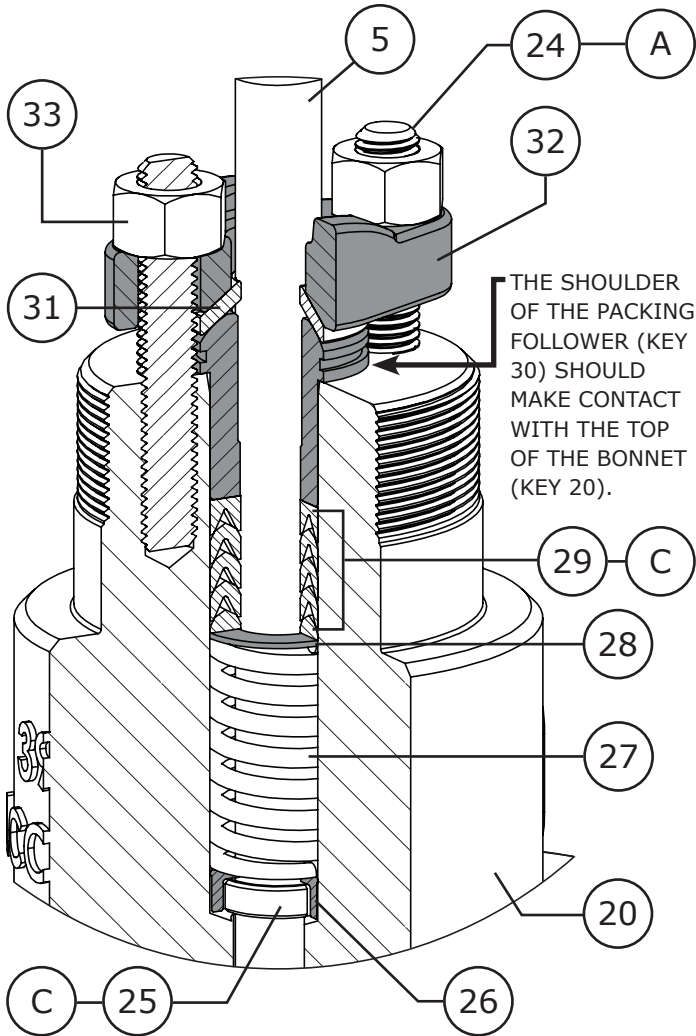

NOTE: SILICONE-BASED O-RING COMPOUND (KEY C) SHOULD NOT BE USED WITH OXYGEN SERVICE.

FOR VACUUM PACKING APPLICATIONS, REVERSE THE DIRECTION OF THE CUP OF THE PTFE PACKING RINGS (KEY 29) AS SHOWN.

ASSEMBLY (Continued)

PACKING INSTALLATION (Continued)

For Double Style PTFE Packing (Continued):

- 9 Thread the packing nuts (Key 33) onto the threads of the packing studs, tighten the packing nuts evenly in an alternating pattern until one of the packing nuts reaches the minimum torque requirement shown in Table 3. Tighten the remaining packing flange nut until the packing flange (Key 32) becomes level (is parallel with the top face of the bonnet), refer to Figure 29.

For Graphite Packing:

- 1 Install the packing box ring (Key 26).
- 2 Install the first lantern ring (Key 34).
- 3 Install the second lantern ring (Key 34).
- 4 Install 1 ring of graphite filament (Key 35) as shown in Figures 27 & 31. **NOTE:** Graphite filament is a wound material with a split that typically looks like rope.
- 5 Install 1 ring of graphite ribbon (Key 36) as shown in Figure 27 & 31. **NOTE:** Graphite ribbon is compressed into rings and not split like the graphite filament.
- 6 Install the remainder of the graphite filament (Key 35) and graphite ribbon (Key 36) one at a time (as shown in Figure 27) in the proper order and orientation as shown in Figure 31.
- 7 Install the packing follower (Key 30).
- 8 Install the packing flange (Key 32).
- 9 Apply anti-seize compound (Key A) to the top threads of the packing studs (Key 24). Thread the packing nuts (Key 33) onto the threads of the packing studs, tighten the packing nuts evenly in an alternating pattern until the packing nuts reach the maximum recommended torque shown in Table 3. Loosen the packing nuts and retighten them to the minimum recommended torque shown in Table 3.

Figure 28 Single Style Packing Installation Diagram

Model 370 & 371 Control Valves

Operation, Parts, and Instruction Manual

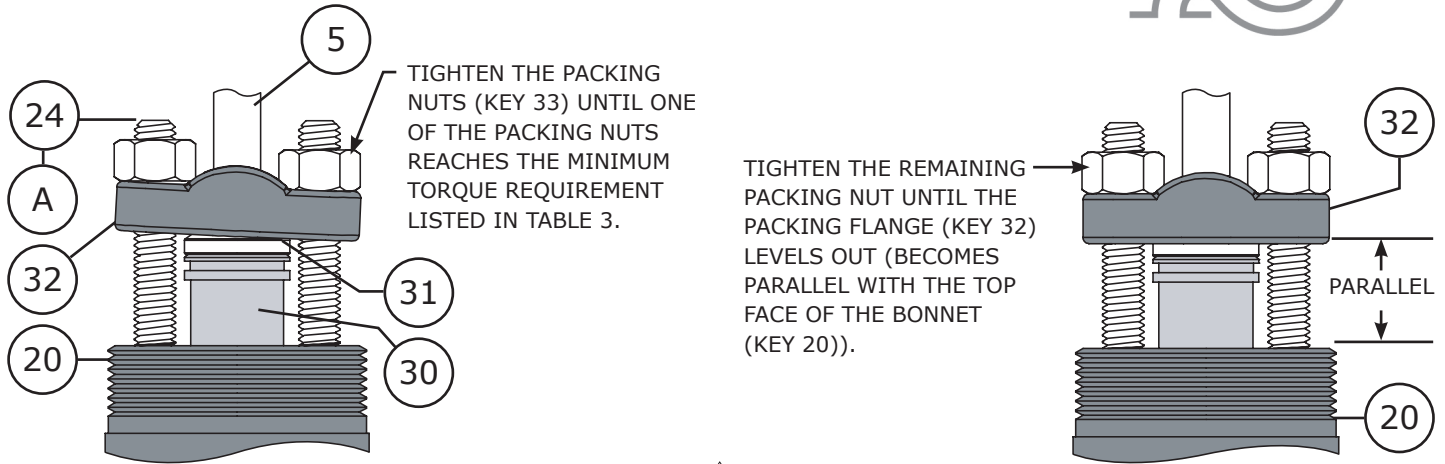

Figure 29 Double PTFE V-Ring Packing Tightening Diagram

Table 2

Body to Bonnet Bolting Torque Values

Stud Size	Bolt Torques B7, B7M, B8M CL2	
	N•m	lbf-ft.
1-3/8"	1356	1000

Table 3

Packing Bolt Torque Values

Valve Stem Diameter Inch (mm)	ASME Class	Packing Flange Nuts (Not Live Loaded)							
		PTFE Packing				Graphite Packing			
		Min. Torque		Max. Torque		Min. Torque		Max. Torque	
		lbf-ft.	N•m	lbf-ft.	N•m	lbf-ft.	N•m	lbf-ft.	N•m
1-1/4 (31.8)	150 & 300	11.8	16	18.4	25	24.3	33	36.1	49
	600	15.5	21	24.3	33	33.2	45	49.4	67

Table 4

Model 371 Seat Ring Cap Screw Torque Values

Bolt Torques	
lbf-ft.	N•m
29	39



Model 370 & 371 Control Valves

Operation, Parts, and Instruction Manual

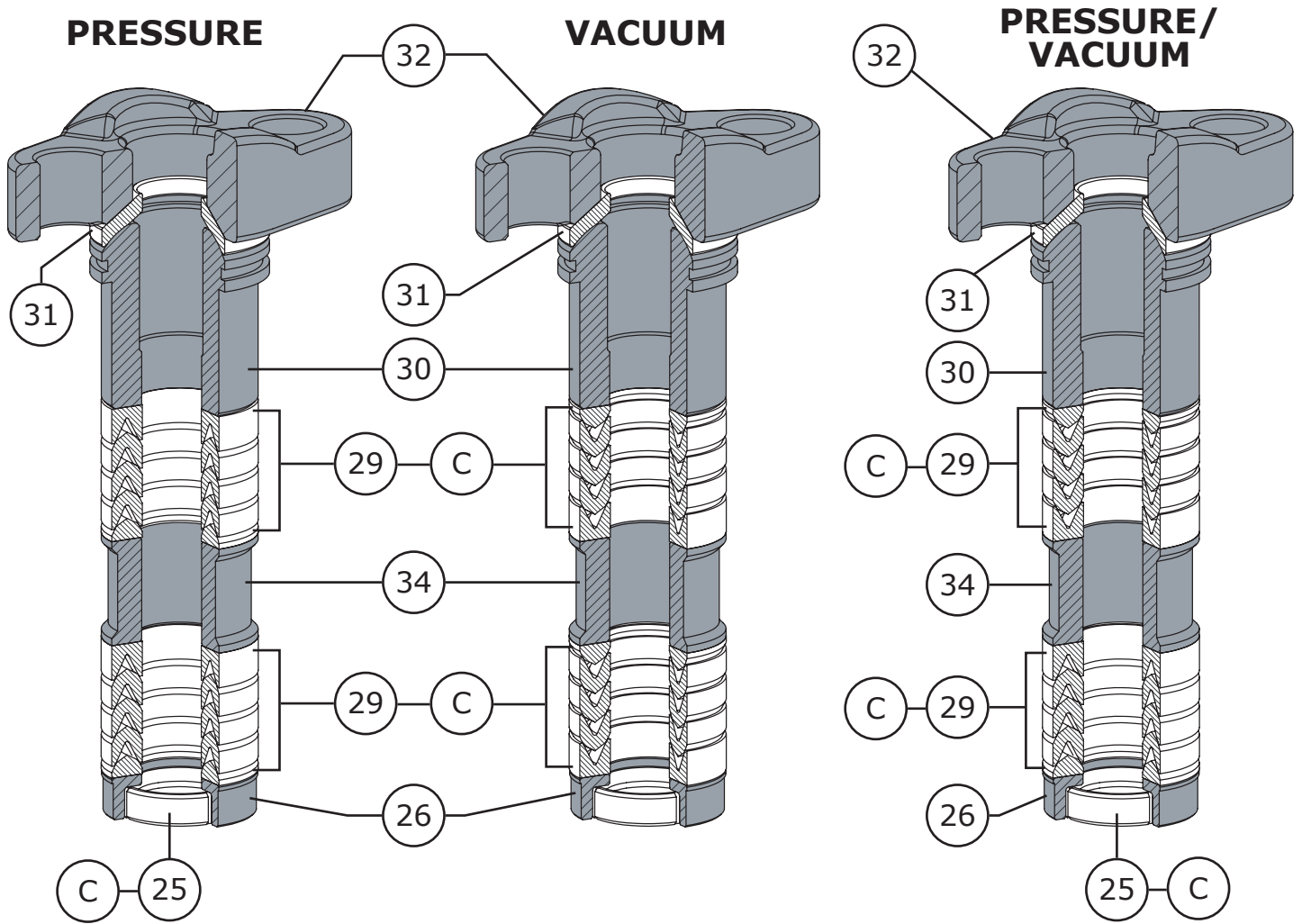
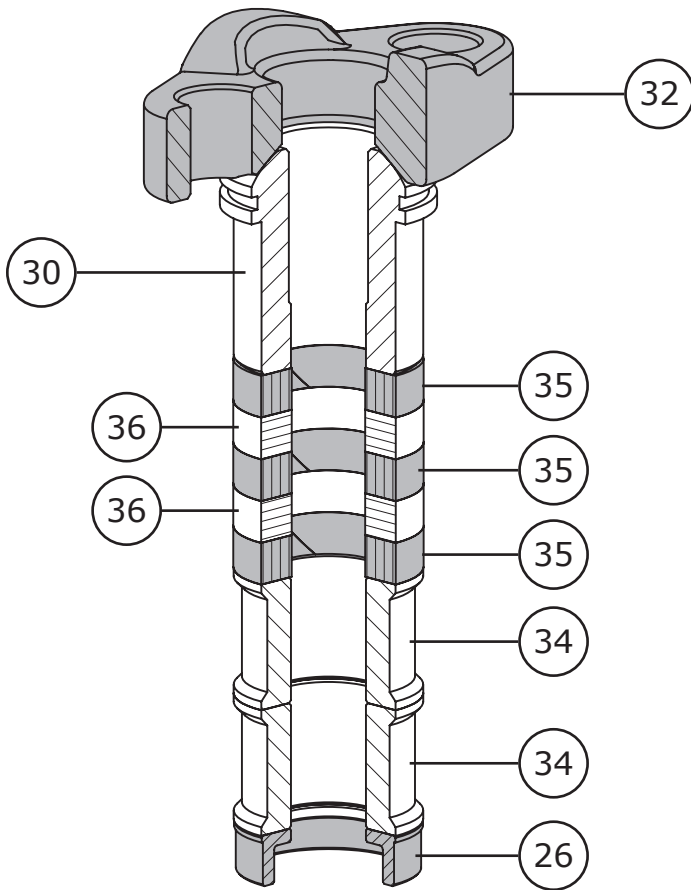

Figure 30 Model 370 Control Valve Double PTFE Packing Diagrams

Model 370 & 371 Control Valves

Operation, Parts, and Instruction Manual



1-1/4" (31.8 mm) Stem

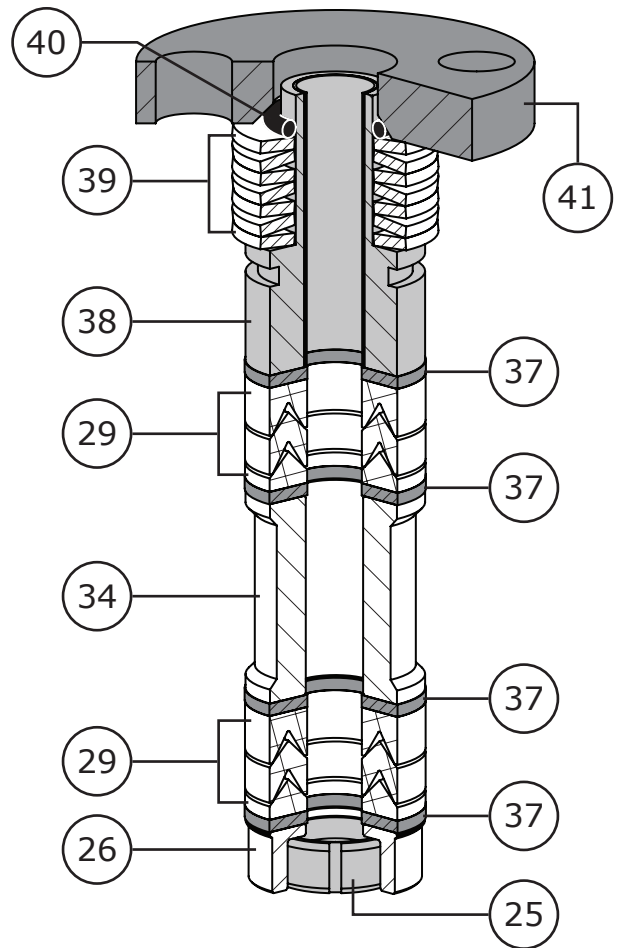

Figure 31 Graphite Packing Arrangement Diagram

Figure 32 Live Loaded PTFE Packing Example

Model 370 & 371 Control Valves

Operation, Parts, and Instruction Manual

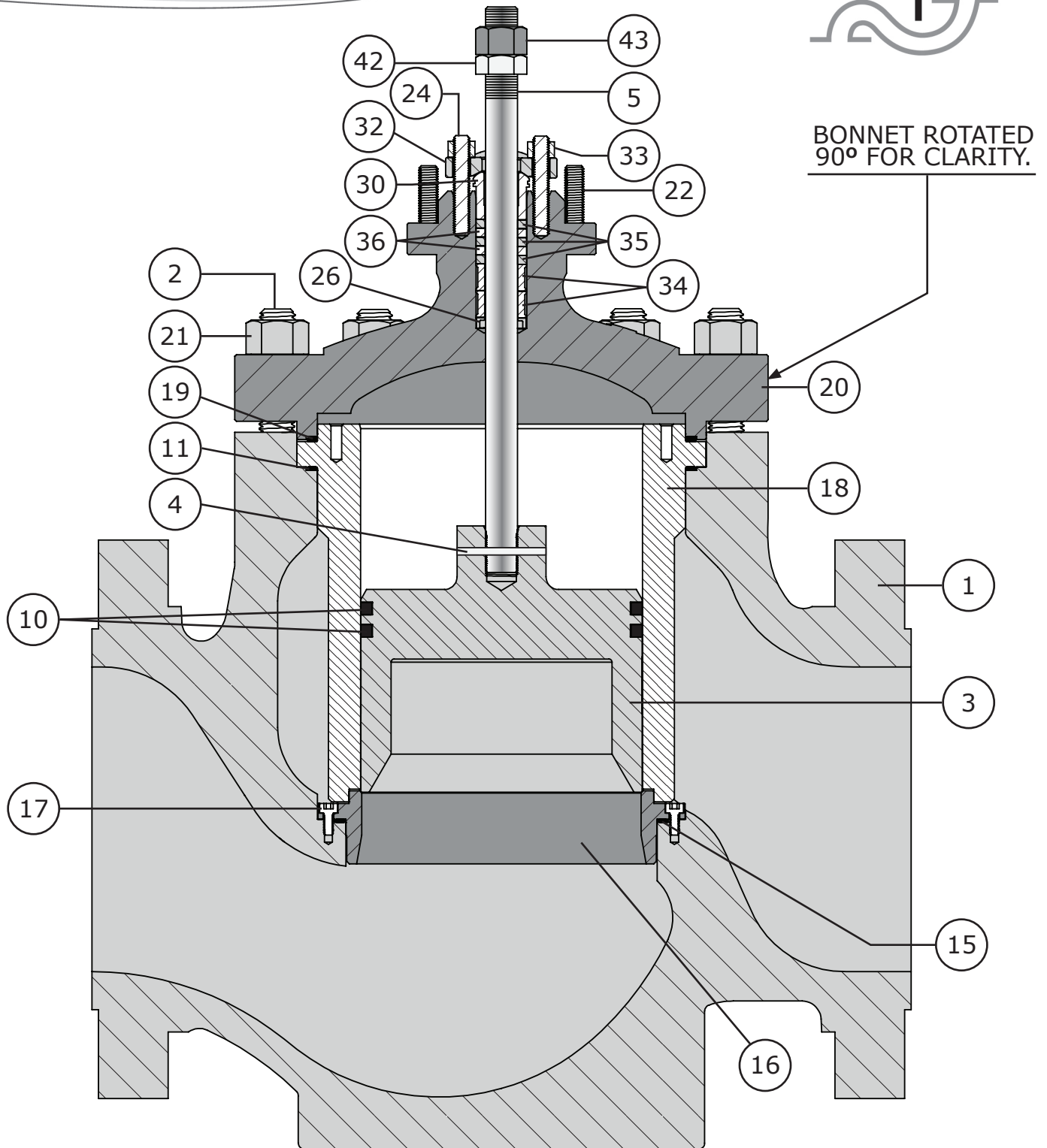

Figure 34 Model 371 Cross Section with Single Graphite Packing



Model 370 & 371 Control Valves

Operation, Parts, and Instruction Manual

Parts

Key	Description	Part Number
1	Body If you need a body as a replacement part, order by valve size and stem diameter, serial number and desired material.	
2	Stud, Bonnet to Body, 16 Required	
	-B7	STB7-138-612
	-B8M	STB8M-138-612
	-B7M	STB7M-138-612
3	Valve Plug	Refer to Tables 5
4	Pin, S20910	370D0001X1A
5	Valve Stem	Consult Dyna-Flo
6	Seal Ring, Model 370 Plug, Spring Loaded Carbon / PTFE / R30003	370B1203X1D
7	Backup Ring, Model 370 (S31600/S31603 Dual Grade) 11 inch port	370B1205X1D
8	Retaining Ring, Model 370, S31600 11 inch port	370B1204X1D
9	Anti-Extrusion Ring, Model 370, 11 inch port	
10	Piston Ring, Graphite, Model 371 Only 10 inch port	370B1216X1D
11	Gasket, Cage, Spiral Wound, N06600 / Graphite	371B1207X1D
12	Seal Ring, Model 370 Seat Ring, Spring Loaded N10276/GLASS & MOLY FILLED PTFE	370B1202X1D
13	Cage, Model 370	Refer to Tables 6
14	Seat Ring, Model 370	Refer to Tables 6
15	Gasket, Seat Ring (Model 371), Spiral Wound, N06600 / Graphite	371B1208X1D
16	Seat Ring, Model 371	Refer to Tables 6
17	Cap Screws, Model 371 material	371B1210X1D
18	Cage, Model 371	Refer to Tables 6
19	Gasket, Bonnet, Spiral Wound, N06600 / Graphite	371B1207X1D

Key	Description	Part Number
20	Bonnet If you need a bonnet as a replacement part, order by valve size and stem diameter, serial number and desired material.	
21	Nut, Bonnet, 16 Required	
	-2H	
	12 Inch	1D71672407D
	-8M	
	12 Inch	1D71673525D
	-2HM	
	12 Inch	1D71672HMDD
22	Stud, Actuator Mounting, 8 Required B8M	1R3690CL28D
23	Nut, Actuator Mounting, 8 Required 8M	1A35203525D
24	Studs, Packing, 2 Required	
	-B8M	
	1 inch (25.4 mm) Stem	0V00253522D
	1-1/4 inch (31.8 mm) Stem (Std.)	1N35653522D
25	Lower Wiper, Teflon	
	1 inch (25.4 mm) Stem	1J87240699D
	1-1/4 inch (31.8 mm) Stem (Std.)	1J87250699D
26	Packing Box Ring, S31600/S31603 Dual Grade	
	1 inch (25.4 mm) Stem	1J87343507D
	1-1/4 inch (31.8 mm) Stem (Std.)	1J87353507D
27	Spring, Packing, SST	Refer to Table 7
28	Special Washer, SST	Refer to Table 7
29	Packing Set, PTFE	Refer to Table 7
30	Packing Follower, S31600/S31603 Dual Grade	
	1 inch (25.4 mm) Stem	1H98233507D
	1-1/4 inch (31.8 mm) Stem (Std.)	1H99843507D
31	Upper Wiper, Felt	
	1 inch (25.4 mm) Stem	1J87290633D
	1-1/4 inch (31.8 mm) (Std.)	1J87300633D
32	Packing Flange,	
	-Carbon Steel - Plated	
	1 inch (25.4 mm) Stem	0V00242505D
	1-1/4 inch (31.8 mm) Stem (Std.)	0W08562505D
	-S31600/S31603 Dual Grade	
	1 inch (25.4 mm) Stem	1H78823507D
	1-1/4 inch (31.8 mm) Stem (Std.)	1J10073507D

Model 370 & 371 Control Valves

Operation, Parts, and Instruction Manual



Parts (Continued)

Key	Description	Part Number
33	Nut, Packing, 2 Required	
	-8M	
	1 inch (25.4 mm) Stem	1A34333525D
	1-1/4 inch (31.8 mm) Stem (Std.)	1A36813525D
34	Lantern Ring, S31600/S31603 Dual Grade	Refer to Table 7
35	Graphite Filament	Refer to Table 7
36	Graphite Ribbon	Refer to Table 7
37	Anti-Extrusion Ring, Live Loaded Packing Refer to the Live Loaded Packing Sliding Stem Instruction Manual (P-LLPS)	
38	Packing Follower, Live Loaded Packing Refer to the Live Loaded Packing Sliding Stem Instruction Manual (P-LLPS)	
39	Spring Washers, Live Loaded Packing Refer to the Live Loaded Packing Sliding Stem Instruction Manual (P-LLPS)	
40	O-Ring, Live Loaded Packing Refer to the Live Loaded Packing Sliding Stem Instruction Manual (P-LLPS)	
41	Packing Flange, Live Loaded Packing Refer to the Live Loaded Packing Sliding Stem Instruction Manual (P-LLPS)	
42	Jam Nut, Valve Stem, Steel / Zinc Plated	
	1 inch (25.4 mm) Stem	
	1-1/4 inch (31.8 mm) Stem (Std.)	NHJFZ114
43	Hex Nut, Valve Stem, Steel / Zinc Plated	
	1 inch (25.4 mm) Stem	
	1-1/4 inch (31.8 mm) Stem (Std.)	NHFZ114
44	Flow Arrow, S30400	1V10603898D
45	Name Plate, S30400	NAMEXSBODYD



Model 370 & 371 Control Valves

Operation, Parts, and Instruction Manual

Table 5

Mode 370 Valve Plug (Key 3)						
Valve Size	Port Size	VSC	Characteristic	Travel	Plug Material	
Inch	Inch (mm)	Inch (mm)		Inch (mm)	S41000	S31600 / Alloy 6 Seat & Guide
12 x 12	11 (279)	1-1/4 (31.8)	Equal Percent Linear Low-Noise III	4 (102) / 5-1/2 (140)	370P2460XCD	370P2461X5D
			Low-Noise III	8 (203)	370P2462XCD	370P2463X5D
14 x 12 16 x 12	11 (279)	1-1/4 (31.8)	Equal Percent Linear Low-Noise III	4 (102) / 5-1/2 (140)	370P2460XCD	370P2461X5D
			Low-Noise III	8 (203)	370P2462XCD	370P2463X5D
Mode 371 Valve Plug (Key 3)						
Valve Size	Port Size	VSC	Characteristic	Travel	Plug Material	
Inch	Inch (mm)	Inch (mm)		Inch (mm)	S41000	S31600 / Alloy 6 Seat & Guide
12 x 12	11 (279)	1-1/4 (31.8)	Equal Percent Linear Low-Noise III	4 (102) / 5-1/2 (140)	371P1200XCD	371P1201X5D
			Low-Noise III	8 (203)	371P1202XCD	371P1203X5D
14 x 12 16 x 12	11 (279)	1-1/4 (31.8)	Equal Percent Linear Low-Noise III	4 (102) / 5-1/2 (140)	371P4600XCD	371P4601X5D
			Low-Noise III	8 (203)	371P4602XCD	371P4603X5D
* - Stem material is S20910.						
- All S31600 barstock is dual grade S31600/S31603 (316/316L).						
VSC = Valve Stem Connection.						

Parts Ordering

Whenever corresponding with Dyna-Flo about a 370 Series Control Valves, refer to the nameplate (Key 45) for the serial number of the unit. Please order by the complete part number (as given in the part lists) of each part required.

Model 370 & 371 Control Valves

Operation, Parts, and Instruction Manual



Table 6

Mode 370 Cage and Seat Ring (Keys 13 & 14)

Valve Size	Port Size	Characteristic	Cage Material		Seat Ring Material	
			S17400 H1075	S31600 Chrome Plated	S17400 H1075	S31600 / Alloy 6
Inch	Inch (mm)					
12 x 12	11 (279)	Equal Percent	370C1101X8A	370C2101X6A	370R1110XAA	370R2110X3A
		Linear	370C1102X8A	370C2102X6A	370R1110XAA	370R2110X3A
		Low-Noise III A1	370C1103X8A	370C2103X6A	370R1110XAA	370R2110X3A
		Low-Noise III A3	370C1104X8A	370C2104X6A	370R1110XAA	370R2110X3A
		Low-Noise III B1	370C1105X8A	370C2105X6A	370R1110XAA	370R2110X3A
		Low-Noise III B3	370C1106X8A	370C2106X6A	370R1110XAA	370R2110X3A
		Low-Noise III C1	370C1107X8A	370C2107X6A	370R1110XAA	370R2110X3A
		Low-Noise III C3	370C1108X8A	370C2108X6A	370R1110XAA	370R2110X3A
14 x 12 16 x 12	11 (279)	Equal Percent	370C1111X8A	370C2111X6A	370R1110XAA	370R2110X3A
		Linear	370C1112X8A	370C2112X6A	370R1110XAA	370R2110X3A
		Low-Noise III A1	370C1113X8A	370C2113X6A	370R1110XAA	370R2110X3A
		Low-Noise III A3	370C1114X8A	370C2114X6A	370R1110XAA	370R2110X3A
		Low-Noise III B1	370C1115X8A	370C2115X6A	370R1110XAA	370R2110X3A
		Low-Noise III B3	370C1116X8A	370C2116X6A	370R1110XAA	370R2110X3A
		Low-Noise III C1	370C1117X8A	370C2117X6A	370R1110XAA	370R2110X3A
		Low-Noise III C3	370C1118X8A	370C2118X6A	370R1110XAA	370R2110X3A

Mode 371 Cage and Seat Ring (Keys 18 & 16)

Valve Size	Port Size	Characteristic	Cage Material		Seat Ring Material	
			S17400 H1075	S31600 Chrome Plated	S17400 H1075	S31600 / Alloy 6
Inch	Inch (mm)					
12 x 12	11 (279)	Equal Percent	371C1101X8D	371C2101X6D	371R1120XAD	371R2120X3D
		Linear	371C1102X8D	371C2102X6D	371R1120XAD	371R2120X3D
		Low-Noise III A1	371C1103X8D	371C2103X6D	371R1120XAD	371R2120X3D
		Low-Noise III A3	371C1104X8D	371C2104X6D	371R1120XAD	371R2120X3D
		Low-Noise III B1	371C1105X8D	371C2105X6D	371R1120XAD	371R2120X3D
		Low-Noise III B3	371C1106X8D	371C2106X6D	371R1120XAD	371R2120X3D
		Low-Noise III C1	371C1107X8D	371C2107X6D	371R1120XAD	371R2120X3D
		Low-Noise III C3	371C1108X8D	371C2108X6D	371R1120XAD	371R2120X3D
14 x 12 16 x 12	11 (279)	Equal Percent	371C1011X8D	371C2011X6D	371R1020XAD	371R2020XAD
		Linear	371C1012X8D	371C2012X6D	371R1020XAD	371R2020XAD
		Low-Noise III A1	371C1013X8D	371C2013X6D	371R1020XAD	371R2020XAD
		Low-Noise III A3	371C1014X8D	371C2014X6D	371R1020XAD	371R2020XAD
		Low-Noise III B1	371C1015X8D	371X2015X6D	371R1020XAD	371R2020XAD
		Low-Noise III B3	371C1016X8D	371X2016X6D	371R1020XAD	371R2020XAD
		Low-Noise III C1	371C1017X8D	371X2017X6D	371R1020XAD	371R2020XAD
		Low-Noise III C3	371C1018X8D	371X2018X6D	371R1020XAD	371R2020XAD



Model 370 & 371 Control Valves

Operation, Parts, and Instruction Manual

Table 7

Packing Parts (Keys 27, 28, 29, 34, 35, & 36)

PTFE Packing

Key #	Description		Stem Diameter Inch (mm)	
			1 (25.4)	1-1/4 (31.8)
27	Packing Spring (S31600) For Single Packing Only.	Part #	1D58293701D	1D38743701D
		Qty.	1	1
28	Special Washer (S30400) For Single Packing Only.	Part #	1H98223604D	1H99593604D
		Qty.	1	1
29*	Packing Set (Refer to Table 8 for Repair Kits)	Part #	1R29060101D	1R29080101D
		Qty. Single	1	1
		Qty. Double	2	2
34	Lantern Ring (S31600/S31603 Dual Grade) For Double PTFE Packing	Part #	DFX0000051D	DFX0000061D
		Qty.	1	1

Graphite Packing

Key #	Description		Stem Diameter Inch (mm)	
			1 (25.4)	1-1/4 (31.8)
34	Lantern Ring (S31600/S31603 Dual Grade)	Part #	DFX0000051D	DFX0000061D
		Qty.	2	2
35	Graphite Filament Ring	Part #	1D7518X013D	1D7520X016D
		Qty.	3	3
36	Graphite Ribbon Ring	Part #	1U6768X002D	J122620165D
		Qty.	2	2

Table 8

Packing Repair Kits

Stem Diameter [Yoke Boss Diameter] inches (mm)	Single		Double
	PTFE	Graphite	PTFE
1 (25.4) [5 (127)]	RPACKX0034D	RPACKX0053D	RPACKX0036D
1-1/4 (31.8) [5 (127)]	—	—	—

Model 370 & 371 Control Valves

Operation, Parts, and Instruction Manual



Our Commitment to Quality

Curtiss-Wright Flow Control Company Canada is committed to continuous improvement. While all efforts have been made to ensure the accuracy of the content in this document, modifications or improvements to the information, specifications, and designs may occur at any time without notice. This document was published for informational purposes only, and does not express or imply suitability, a warranty, or guarantee regarding the products or services described herein or their use or applicability.

Neither Curtiss-Wright Flow Control Company, nor any of their affiliated entities assumes responsibility for the selection, use and maintenance of any product. Responsibility for selection, use and maintenance of any product remains with the purchaser and end-user.

Model 370 & 371 Control Valves

Operation, Parts, and Instruction Manual



This page left intentionally blank.

Model 370 & 371 Control Valves

Operation, Parts, and Instruction Manual



This page left intentionally blank.



Model 370 & 371 Control Valves

MODEL NUMBERING SYSTEM

SAMPLE PART NUMBER: 370-BAFL-14P5-GES4

VALVE MODEL						370	
370	370	371	371				
FLANGE SIZE X VALVE SIZE						B	
B	12 X 12 INCH	C	14 X 12 INCH	D	16 X 12 INCH		
ASME RATING						A	
A	150	B	300	C	600		
END CONNECTION						F	
F	RF						
BODY MATERIAL						L	
L	LCC	W	WCC	M	CF8M		
BOLTING						-	
-	B7 / 2H (STANDARD)			A	B7M / 2HM		
B	B8M / 8M			K	B7 FLUOROKOTE #1 / 2H FLUOROKOTE #1		
L	B7M FLUOROKOTE #1 / 2HM FLUOROKOTE #1						
TRIM						1	
1	L1	2	L2				
TRAVEL						4	
4	4 INCH	5	5.5 INCH	8	8 INCH		
PACKING STYLE						P	
P	SINGLE PTFE V-RING (PRESSURE)			J	DOUBLE PTFE V-RING (PRESSURE)		
G	SINGLE GRAPHITE (PRESSURE)			V	DOUBLE PTFE V-RING (VACUUM)		
R	DOUBLE PTFE V-RING (VACUUM / PRESSURE)			L	LIVE LOADED PTFE V-RING (PRESSURE)		
T	LIVE LOADED GRAPHITE (PRESSURE)			K	LIVE LOADED KALREZ®		
YOKE BOSS SIZE						5	
H	5H (1-1/4" STEM)						
SEAL RING / PISTON RING						G	
C	GLASS / MOLY FILLED PTFE / N10276 SEAL RING (MODEL 370)						
G	GRAPHITE PISTON RING (MODEL 371)						
CHARACTERISTIC						E	
E	EQUAL PERCENT	L	LINEAR	A	ANTI-CAVITATION 1 STAGE		
W	LOW-NOISE III A1	G	LOW-NOISE III A3	B	LOW-NOISE III B1	H	LOW-NOISE III B3
C	LOW-NOISE III C1	J	LOW-NOISE III C3				
BONNET STYLE						S	
S	STANDARD						
SHUTOFF CLASS						4	
4	CLASS IV	5	CLASS V				

