

Model 5000 Level Controller

Operation, Parts, and Instruction Manual



TABLE OF CONTENTS

General	2
Scope	2
Specifications	2
Unpacking	4
Installation	4
Displacer Arm Installation	4
Controller to Vessel Installation	4
Electric Pilot Installation	5
Figure 2 - Wiring Diagram	6
Air Piping	6
Liquid Level Operation Adjustment	7
Principles of Operation	8
Controller Action	8
Proportional Band	8
Electric Level Switch	8
Figure 3 - Proportional Band Adjust.	8
Figure 4 - Level Adjustment	9
Pneumatic Pilot Operations	9
Snap (On/Off) Pilot	9
Throttle Pilot	10

Figure 7 - Controller Operation	10
Changing Controller Action	11
Controller Maintenance	11
Replacing Gauges	11
Controller / Body Disconnection	12
Seal Replacement	12
Re-Assembly	12
Pneumatic Pilot Maintenance	13
Pneumatic Pilot Installation	14
Pilot Removal	14
Electric Pilot Installation	14
Figure 8, 9, 10 - Displacer Diagrams	15
Figures 11 to 13 - 5000 Cross Section	16
Figures 14 & 15 - Trunnion Assembly	17
Figure 17 - Manual Test Apparatus	19
Figure 18 & 19 - Electric Pilot	20
Parts	21
Replacement Parts Kits	23
Model Builder	24



Model 5000 Level Controller

Operation, Parts, and Instruction Manual

NOTICE

These instructions are meant to be used with the Dyna-Flo 5000 Series Technical Bulletin as they refer to Figures and Tables therein. If you do not have the Technical Bulletin, contact Dyna-Flo immediately, or visit www.dynaflo.com

Each controller is factory checked. Check the calibration for the specific application, before a controller is put into service.

GENERAL

The following instructions are to be thoroughly reviewed and understood prior to installing, operating or performing maintenance on this equipment. Work on this equipment should be done by experienced personnel. Throughout the manual, safety and caution notes appear and must be strictly followed, to prevent serious injury or equipment malfunction.

SCOPE

The controller configuration and construction materials were selected to meet particular pressure, temperature, and process fluid conditions. Some material combinations are limited in their pressure and temperature ranges. Do not apply any other conditions to the controller without first contacting your Dyna-Flo sales office.

This manual is written to be a practical and useful guide maintaining the Dyna-Flo 5000 Level Controller.

! CAUTION !

To avoid personal injury or installation damage as a result of the sudden release of process pressure or the breaking of parts, do not install the controller assembly where service conditions could exceed the limits stated in this manual or on the equipment nameplates. Use government codes, accepted industry standards and good piping practices to select pressure-relieving equipment for protection of your installation. It is also important to wear the proper protective equipment when performing any installation or maintenance activity.

SPECIFICATIONS

Configurations

Controllers

- Throttling
- Snap-acting

Sensors

Pivotal movement of displacer arm is transmitted to the controller by a displacer-style liquid level sensor mounted to the side of tank.

Standard Displacer Size

1-7/8" x 12 inches, 33 inches³ (48 x 305 mm, 541 cm³).

Minimum Specific Gravity

Snap-Acting Controller

Minimum specific gravity (specific gravity differential for interface applications) 0.1.

Throttling Controller

Minimum specific gravity (specific gravity differential for interface applications) 0.1.

Model 5000 Level Controller

Operation, Parts, and Instruction Manual



SPECIFICATIONS - Continued

End Connection	Maximum Pressure Rating at 38°C (100°F)
MNPT	3,750 Psig (25,855 kPag)
150 RF	285 Psig (1,965 kPag)
300 RF	740 Psig (5,102 kPag)
600 RF	1,480 Psig (10,204 kPag)
600 RTJ	1,480 Psig (10,204 kPag)
900 RF	2,220 Psig (15,306 kPag)
900 RTJ	2,220 Psig (15,306 kPag)
1500 RF	3,750 Psig (25,855 kPag)
1500 RTJ	3,750 Psig (25,855 kPag)

Pilot

Pneumatic (standard)

- **Snap** - (on/off) 0-20 / 0-30 psig output.
- **Throttle** - (modulating) 3-15 / 6-30 psig output.

Electric (optional)

- **SPDT** - Explosion Proof.
- **DPDT** - Explosion Proof.

Supply Pressure Requirements

Snap-Acting Controller

- 3-15 or 0-20 psig output: 20-30 psig min.
- 6-30 or 0-30 psig output: 35-40 psig min.

NOTE

Do Not Use Supply Pressure Below 20 psig (138 kPag).

Maximum Sensor Operating Pressure

Conforming with Class 1500 pressure temperature ratings per ASME B16.34 up to maximum pressure of 3,750 psig (25,855 kPag).

Maximum Displacer Operating Pressure

3,750 psig (25,855 kPag).

Standard Pressure Gauge Indications - (Supply and Output)

Triple scale gauges in: 0 to 60 psig / 0 to 0.4 MPa / 0 to 2,758 kPag.

Controller Connections

Output

1/4 inch NPT female (located on back of case).

Supply

1/4 inch NPT female (located on the back of case).

Case Vent

1/4 inch NPT (located on bottom of case), vent screen apparatus included.

Vessel to Sensor Connection

1-1/2", 2", 3", and 4" threaded (NPT) or flanged.

Sensor Temperature Limits

PVC Displacer

-29 to 80°C (-20 to 175°F).

HSN (Highly Saturated Nitrile) O-Rings

-40 to 204°C (-40 to 400°F).

Viton O-Rings

-26 to 204°C (-15 to 400°F).

316 SST Displacer

Non-limiting.

Operative Ambient Temperature Limits

For Controller: -29 to 204°C (-20 to 400°F)

SPECIFICATIONS - Electric Pilot

Output - proportional band adjustment

SPDT (single pole double throw)

7 - 55%

DPDT (double pole double throw)

20 - 150%

Switch Rating

UL and CSA listed: L96

15 amps, 125, 250, or 480 V.A.C.

1/8 Hp, 125 V.A.C.; 1/4 Hp, 250 V.A.C.

1/2 amp, 125 V.D.C.; 1/4 amp, 250 V.D.C.

Electric Pilot Model Number

SPDT (single pole double throw)

EX-Q

DPDT (double pole double throw)

EXD-Q

Certifications

Approvals: UL, CSA, ATEX (CE), IEC EX

Designations:

Div. 1 & 2, Class I, Groups B, C, & D

Div. 1 & 2, Class II, Groups E, F, & G

II 2 G; EEX d IIB + H2 T6

Temperature Rating

-40 to 71°C (-40 to 160°F)



Model 5000 Level Controller

Operation, Parts, and Instruction Manual

UNPACKING CONTROLLER FROM SHIPPING CONTAINER

Check the packing list against materials received, while unpacking the controller. The Packing List describes controller and accessories in each shipping container.

INSTALLATION

NOTE

If the Model 5000 Level Controller is to be installed into a vessel that will be moved to another location once assembly is complete it will be necessary to remove the displacer arm (Key 42) before transportation. Shipping the 5000 Level Controller with the displacer arm installed in the vessel will cause damage to the level controller.

- 1 Check to make sure that there are no obstructions inside the vessel that would block the installation of the level controller.
- 2 Locate the vessel wall sensor connection that will be used to place the level controller at the appropriate control level for operations. Once the appropriate connection is located verify that it is equipped with the proper end connection.
- 3 Make sure that the desired vessel connection is capable of supporting the weight of the level controller, if it is inadequate it may be necessary to reinforce the connection.

Displacer Arm Installation

(Reference Figures 8, 9, and 10)

NOTE

Make sure that the fulcrum bar pin (16A) is resting inside the trunnion head groove. If the fulcrum bar pin is not properly inserted into the trunnion head groove, it may be difficult to install the displacer arm (Key 42). Lubrication of the displacer arm is unnecessary, the displacer arm o-ring is already properly lubricated.

- 1 Begin by inserting the 1/4" threads of the displacer arm (Key 42) through the NPT connection as shown in Figure 11. The threads of the displacer arm should protrude past the trunnion head (Key 39). It may be necessary to re-position the trunnion head periodically while inserting the displacer arm.

- 2 Install the 1/4" (star) lockwasher (Key 44) over the displacer arm and snug it up to the trunnion head.
- 3 Thread the 1/4" fine nut (Key 45) over the displacer arm and tighten to 12 ft-lb.

Vertical Displacer Assembly

(Reference Figures 8, 9, and 10)

Assuming that the displacer arm (Key 42) has already been correctly installed into the 5000 controller.

- 1 Thread the swivel assembly (Key 46) onto the end of the displacer arm (Key 42). Hold the displacer arm in place with a pair of pliers or vice grips and use a 1/2" wrench to completely tighten the swivel assembly to the displacer arm.
- 2 Make sure the jam nut (Key 43) is threaded to the top of the swivel bolt. Thread the displacer (Key 41) onto the swivel bolt as far as possible. Tighten the jam nut into the displacer using a 1/2" wrench.

Horizontal Displacer Installation

(Reference Figures 8, 9, and 10)

Assuming that the displacer arm (Key 42) has already been correctly installed into the 5000 controller.

- 1 Remove the jam nut (Key 43) from the swivel bolt and thread it onto the end of the displacer arm (Key 42) as far as it will go.

NOTE

It may be necessary to hold the displacer arm with a pair of pliers or vice grips when performing the following steps.

- 2 Thread the displacer (Key 41) onto the displacer arm until it makes contact with the jam nut.
- 3 Using a 1/2" wrench, tighten the jam nut back into the displacer.

Controller to Vessel Installation

WARNING

Use caution when moving an assembled controller, stress applied to the displacer arm (Key 42) while moving or carrying the controller can damage the displacer arm and impair controller function.

Once the controller is completely assembled, insert the displacer (Key 41) into the connection port of the vessel or tank.

Model 5000 Level Controller

Operation, Parts, and Instruction Manual



Controller to Vessel Installation

(Continued)

NOTE

The functions of the 5000 Level Controller are dependent on gravity. It is vital to the performance of the controller that the bottom of the controller case (Key 13) be parallel to the ground. See Figure 7.

NPT Connections

Follow good piping practices and screw the threads of the controller body (Key 12) into the threads of the vessel connection until the controller is tight enough to seal the connection. Adjust the orientation of the controller so that it is level (the bottom of the case is parallel to the ground) by slightly loosening or tightening as necessary.

Flanged Connections

Before installing the controller be sure to inspect the flange mating surfaces on both the controller and the pipeline flanges. Also check the pipeline flanges for alignment. Install line gaskets and studs, use a thread lubricant on each end of the studs and tighten the nuts to the correct torque specifications, evenly, using a crisscross pattern.

Sensor Check

Once installed into the vessel, check that the controller displacer is able to move freely inside the vessel. Open the case (Key 13) and rock the trunnion head (Key 39) to test that the displacer arm (Key 42) moves without obstruction inside the vessel. Ensure that the fulcrum bar pin (Key 16A) remains seated in the trunnion head pivot hole once the test is completed.

Electric Pilot Installation

General Information

The flame paths of Honeywell's EX explosion-proof switches cool exploding gases below the ignition temperature before they reach explosive gases surrounding the housing. The enclosed replaceable basic switch is accessible when the cover is removed. EX series products are NEMA 1 rated and therefore are not recommended for use in areas when they will be subjected to liquid splash

EX series products are listed by Underwriters' Laboratories and CSA for use in hazardous locations NEMA 7, Class I, Groups C & D, and NEMA 9, Class II, Group E, F, and G. This includes vapors of ethyl ether, gasoline, petroleum, alcohol, acetone, lacquer solvent, natural gas, and atmospheres charged with grain dust, metal dust, carbon black, coal, or coke dust. Select EX listings are also listed for Class I, Group B (hydrogen) atmospheres. CSA requires the following statement for Class I, Group B requirements.

DANGER

EMISSION OF HOT PARTICLES - Joint surfaces must be thoroughly cleaned before closing. Failure to comply with these instructions will result in death or serious injury.

All EX series products comply with UL Standard: UL 894 and UL 1203, CSA Standard: C22.2 no. 25-1966, C22.2 no. 30-M1986. EX series products also meet NEMA 1 enclosure requirements.

Select EX Series products also meet the European Hazardous Locations Designation: Exd IIB + H2 T6 category II 2 G, KEMA 04ATEX2312X and complies with the European Directive on Equipment and Protective Systems Intended for Use in Potentially Explosive Atmospheres (94/9/EC) commonly referred to as the ATEX Directive. Compliance with the Essential Health and Safety Requirements has been assured by compliance with EN50014:1997, EN50018:2000 and EN50281-1-1:1998. EX series products have a temperature range of -40°C to 70°C (-40°F to 158°F), and when used within the maximum voltage and current specified on the product will have no heating problems.

Wiring Instructions

Use up to size #14 AWG solid or stranded wires to connect to the pressure-type connector terminals. Use green wires for ground leads, red wires for NC leads, blue wires for NO leads, and black for common leads.

Cable Connection

The cable entry device shall be certified in type of protection flameproof enclosure "d", suitable for the conditions of use and correctly installed. For ambient temperatures above 60°C (140°F), cables and cable glands suitable for a temperature of at least 80°C (176°F) are required.

Conduit Connection

A certified sealing device in type of protection flameproof enclosure "d", such as a conduit seal with setting compound shall be provided immediately to the entrance of the enclosure.

For ambient temperatures over 60°C (140°F), suitable heat resistant wiring and setting compound in conduit seal shall be used. Blanking elements of unused apertures shall be certified in type of protection flameproof enclosure "d", suitable for the conditions of use and correctly installed.



Model 5000 Level Controller

Operation, Parts, and Instruction Manual

ELECTRIC PILOT SWITCH CIRCUITRY

CODE	MICRO SWITCH CIRCUITRY		ELECTRICAL RATING
"E" EX-Q	<p>Single - Pole Double - Throw</p>	A	UL and CSA Listed: 15 amps, 125, 250 or 480 VAC 1/8 hp, 125 VAC; 1/4 hp, 250 VAC; 1/2 amp, 125 VDC; 1/4 amp, 250 VDC
"D" EXD-Q	<p>Green - GROUND</p> <p>BLACK - COM 1</p> <p>BLACK - COM 2</p> <p>Double - Pole Double - Throw</p> <p>BLUE - N. O. 1</p> <p>RED - N. C. 1</p> <p>BLUE - N. O. 2</p> <p>RED - N. C. 1</p>	B	UL and CSA Listed: 10 amps, 125 or 250 VAC; 0.3 amp, 125 VDC; 0.15 amp, 250 VDC

Figure 2 Electric Pilot Wiring Diagram

INSTALLATION

(Continued)

Air Piping

WARNING

Property damage, environmental harm, and personal injury can result from the use of a supply gas other than clean, non-corrosive, oil and moisture free air. The 5000 Level Controller vents supply gas through the bottom of the controller, if hazardous or flammable gas is to be used as the supply medium it may be necessary to install a remote vent line. Always ensure there is adequate ventilation is present and that filters are receiving regular maintenance when using the 5000 Level Controller.

- 1 Be sure the operating medium supplied to the controller meets the requirements of ISA Standard 7.0.01 and supply pressure requirements (see Page 3). The use of a supply medium that does not meet the requirements of ISA Standard 7.0.01 may damage the controller.

- 2 Connect the supply pressure to the 1/4" NPT SUPPLY port on the back of the controller case (Key 13).
- 3 Connect a line from the 1/4" NPT OUTPUT port on the back of the controller case to the equipment being operated.

Remote Venting

CAUTION

Venting and vent lines should comply with local and regional codes and regulations.

- 1 Remove the vent (Key 14) if present at the bottom of the case (Key 13). Venting occurs through the adjusting thread (Key 11).
- 2 Connect a 1/2" diameter pipe to the vent port, make sure the pipe is free of foreign material and protected against foreign material entering the line. The pipe should have an adequate inside diameter and possess as few bends as possible to reduce case pressure.

Model 5000 Level Controller

Operation, Parts, and Instruction Manual



CONTROLLER LIQUID LEVEL OPERATION ADJUSTMENT (Reference Figure 4)

- 1 Check that the supply pressure is set properly by checking the supply pressure gauge (Key 52). Adjust the supply pressure if necessary.
- 2 Check that the displacer (Key 41) and displacer arm (Key 42) are able to move freely inside the vessel by rocking either the trunnion head (Key 39) or fulcrum block assembly (Key 16), ensure that the fulcrum bar pin (Key 16A) remains seated in the trunnion head pivot hole once the check is completed. The displacer arm (Key 41) should be reasonably level after checking the movement, if not, adjust the spring adjuster (Key 27) until the fulcrum bar assembly (Key 16) and displacer arm are in the horizontal position.
- 3 Loosen the fulcrum block thumb screw (Key 17A) and position the fulcrum block (Key 17) about a half inch (0.5") from the center of the fulcrum bar (Key 16).

NOTE

It is recommended that controller level adjustments be made within the required operating pressure range. For example, if adjusting within a 3 – 15 Psig range, do not adjust up to 17 Psig and then back into the 3 – 15 range.

- 4 Lower the liquid level in the vessel until it is either below the bottom of the displacer or at the lowest required operating point.

For applications involving liquid level interface, completely submerge the displacer in the fluid with lower density (the upper fluid). The fluid with the higher density (the lower fluid) should be below the displacer or at the lowest desired operating point on the displacer.

- 5 Operation Specific Adjustment

Direct-Acting / Snap Pilot Controller

- A Turn the spring adjuster (Key 27) until the output pressure reaches full supply pressure.
- B Adjust the spring adjuster until the output pressure drops to zero Psig.

Reverse-Acting / Snap Pilot Controller

- A Turn the spring adjuster (Key 27) until the output pressure reaches zero Psig.

- B Adjust the spring adjuster until the output pressure rises to full supply pressure.

Direct-Acting / Throttle Pilot Controller

3 – 15 Psig

Turn the spring adjuster (Key 27) until the output pressure is around 6 Psig then adjust the output pressure down to 1 - 2 Psig.

6 – 30 Psig

Turn the spring adjuster (Key 27) until the output pressure is around 8 Psig then adjust the output pressure down to 2 - 4 Psig.

Reverse-Acting / Throttle Pilot Controller

3 – 15 Psig

Turn the spring adjuster (Key 27) until the output pressure is around 10 Psig then adjust the output pressure up to 16 - 17 Psig.

6 – 30 Psig

Turn the spring adjuster (Key 27) until the output pressure is around 25 Psig then adjust the output pressure up to 31 - 34 Psig.

Electric Pilot Controller

NOTE

The 5000E electric pilot behaves as a snap (on/off) pilot, adjust liquid level operation accordingly. Proper operational performance of the electric pilot is tested in factory. Always have a certified electrician perform all wiring on the 5000E electric pilot controller.

- A Using the hex key provided (located in the bottom of the controller case, Key 19) loosen the 4 socket cap screws and remove the front panel of the electric pilot.
- B Have a certified electrician refer to the Electric Pilot Switch Circuitry diagram (Figure 2) for wiring instructions. Wiring should be fed into the electric pilot through the nipple (Key 66) located on the right side of the controller.
- C Once wiring is complete, close the front panel of the electric pilot using the 4 socket cap screws and the hex key provided.

For more information refer to the Honeywell Explosion Proof Switch Installation and Service Instructions included with your 5000E Level Controller.



Model 5000 Level Controller

Operation, Parts, and Instruction Manual

PRINCIPLES OF OPERATION

The Series 5000 liquid level controller utilizes the "Force Balance System" (Figure 4). Force is applied to the fulcrum bar (Key 16) distributed from the displacer-style level sensor (Key 42) using a series of levers and rods. The application of force to the fulcrum bar is a direct result of the weight of the displacement type sensor. Forces acting on the fulcrum bar are balanced using a compressed spring (Key 26) on one side of the bar. As fluid levels in the tank increase the buoyant force acting on the displacer decreases its relative weight. Force applied to the fulcrum bar is, in turn, decreased resulting in the rotation of the fulcrum bar until the forces are balanced again. A fulcrum (Key 17) mounted to the flapper shaft (Key 15) relays rotation of the fulcrum bar to the pilot. Desired controller output can be regulated by adjusting the position of the fulcrum on the fulcrum bar. By using a Throttling Pilot (Figure 6), a pneumatic modulating signal is achieved. A Snap-Acting Pilot (Figure 5) will result in a pneumatic on/off signal. Electrical SPDT or DPDT output is attained by utilizing an electrical limit switch (Figure 17).

Controller Action

The installation of the flapper shaft (Key 15) determines controller action (Figure 7). When controller output is effected in the same as liquid level, the control is considered "Direct-Acting". When the vessel liquid level increases, the output signal will increase and vice versa. For example, when the flapper shaft is positioned on the left hand mount, the result is "Direct-Acting" control. "Reverse-Acting" control is achieved when change in liquid level results in a reverse effect to the pilot. As liquid level increases, controller output will decrease. When the flapper shaft is positioned on the right hand mount, the controller is considered "Reverse-Acting".

Proportional Band

Proportional Band is the ratio of used displacer length versus the total length of the displacer. Proportional Band is used in order to achieve a desired output signal (Figure 3).

For example if a 12" long vertical displacer is used with six inches of fluid level change in order to develop a required output signal (ex: 3-15 psig), then the controllers Proportional Band is considered to be 50%.

Adjusting the fulcrum (Key 17) towards the pivot pin away from the retaining ring (Key 26) will increase Proportional Band (decreasing sensitivity)(See Figure 3). By adjusting the fulcrum away from the pivot pin towards the snap-ring will decrease Proportional Band (increasing sensitivity). Adjusting the fulcrum as described above (over any portion of the displacer) can achieve a desired output signal such as 3-15 psig or 6-30 psig.

Electric Level Switch

The electric level switch uses the force balance principle to open and close an electrical switch in response to rising or falling levels. Two standard switches are available, single pole double throw (SPDT) or double pole double throw (DPDT), both with explosion-proof enclosure.

Figure 3 Proportional Band Adjustment Diagram

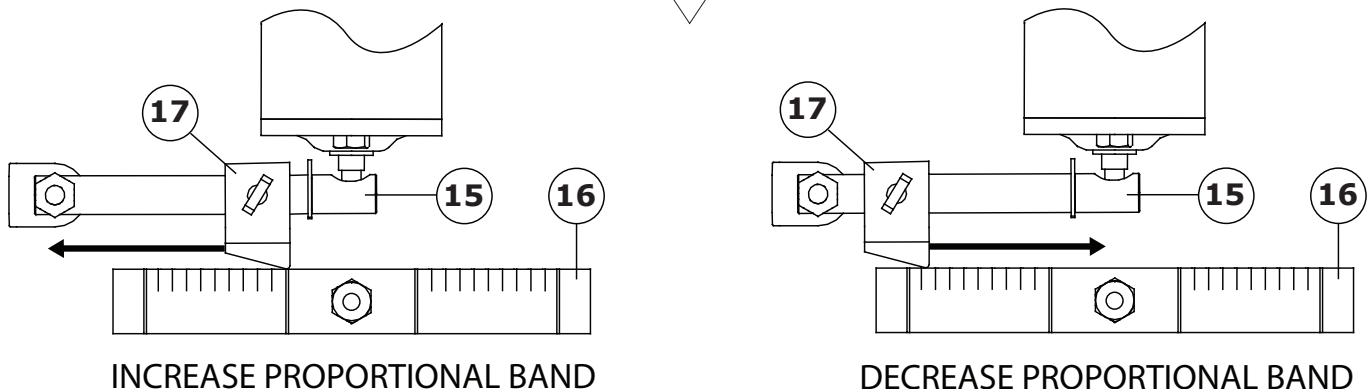

Model 5000 Level Controller

Operation, Parts, and Instruction Manual



PRINCIPLES OF OPERATION

(Continued)

Activation

Adjust the spring compression (Key 26) by setting the spring adjuster (Key 27) to position the displacer arm. Move the fulcrum bar by hand to check that the displacer arm is not resting against the vessel connection.

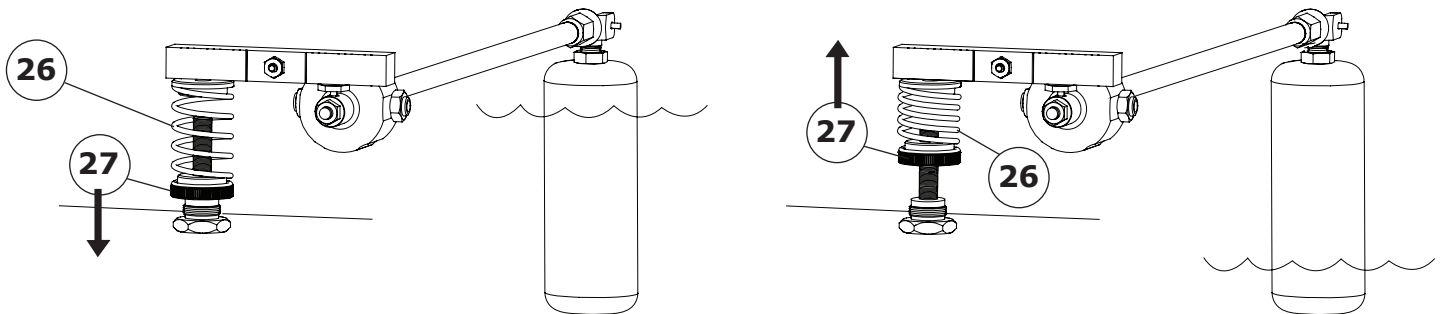

To Increase Level:
Turn the Spring Adjuster clockwise to decrease spring compression.

To Decrease Level:
Turn the Spring Adjuster counter-clockwise to increase spring compression.

Figure 4 Liquid Level Adjustment Diagram

PNEUMATIC PILOT OPERATIONS

Snap (On/Off) Pilot Operation

Two valves compose the Snap pilot (Figure 5); one valve to exhaust system pressure and one to admit supply pressure. Flow of supply pressure gas into the pilot is controlled by the ball (Key 47), force exerted by supply pressure holds the pilot closed by forcing the ball on the pilot seat.

When sufficient force is transferred from the flapper shaft (Key 15) to the thrust pin (Key 58), the ball will snap off the seat, releasing supply gas through the output port. As soon as the ball snaps open, the seating end of the thrust pin seats and simultaneously closes the exhaust port. Because the thrust pin has a smaller seating area than the ball, the thrust pin can remain seated against the force of supply pressure until force from the flapper shaft (Key 15) subsides.

The "snap" action occurs as a result of differences in seating area between the ball and thrust pin. Once force from the flapper shaft subsides, supply pressure will unseat the thrust pin and simultaneously seat the ball. As the thrust pin is unseated it opens the exhaust port, venting supply gas.

Figure 5 Snap (On/Off) Pilot

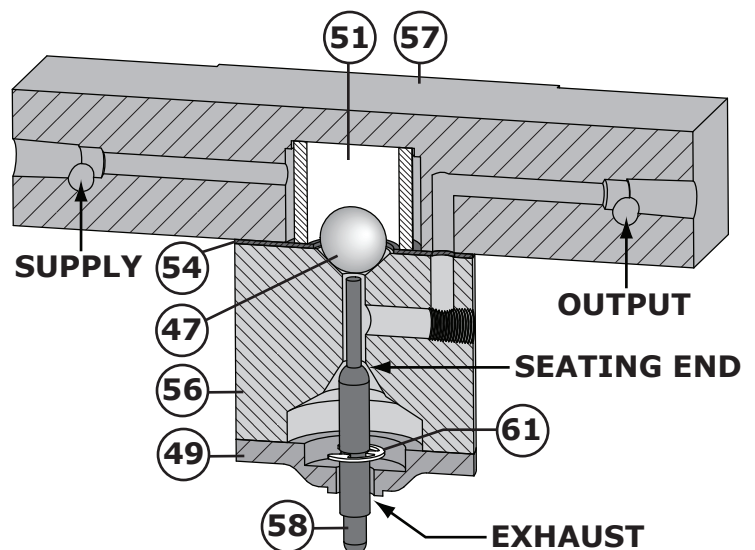



Model 5000 Level Controller

Operation, Parts, and Instruction Manual

PNEUMATIC PILOT OPERATIONS

(Continued)

Throttle Pilot Operation

A Throttle pilot (Figure 6) is similar to the Snap Pilot, both consist of two inner valves. The difference between Snap and Throttle being the use of a resilient diaphragm (Key 61). A Force Balanced pilot is created utilizing the resilient diaphragm in conjunction with valves 'A' and 'B'. Force Balance occurs as a result of supply pressure acting on the resilient diaphragm equalizing force applied to it and force exerted by the flapper shaft (Key 15).

In a Throttling Pilot the force applied by the flapper shaft to the lower seat becomes relational to the force of output pressure. Increasing the amount of force applied to the flapper shaft will proportionally increase the amount of output pressure.

As force applied to the thrust pin (Key 59) changes, the pilot compensates by unseating valve 'A' to increase output pressure or by exhausting supply output at valve 'B', resulting in a new balance point. While the pilot is in balance, supply gas will not flow.

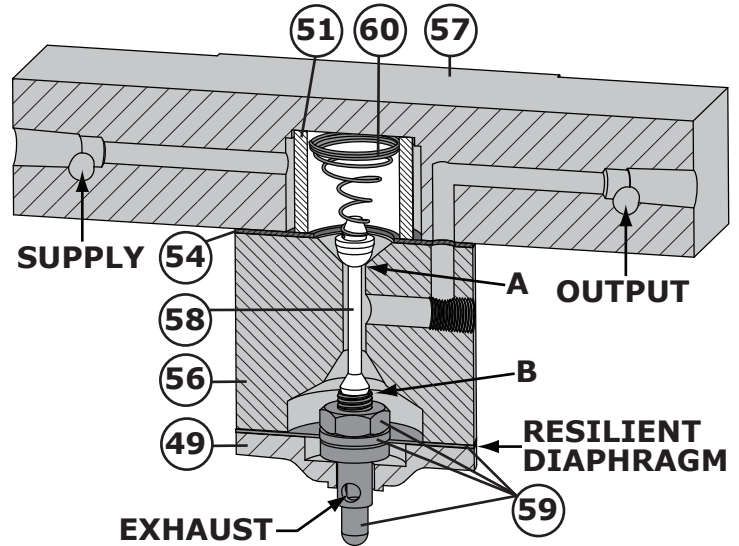
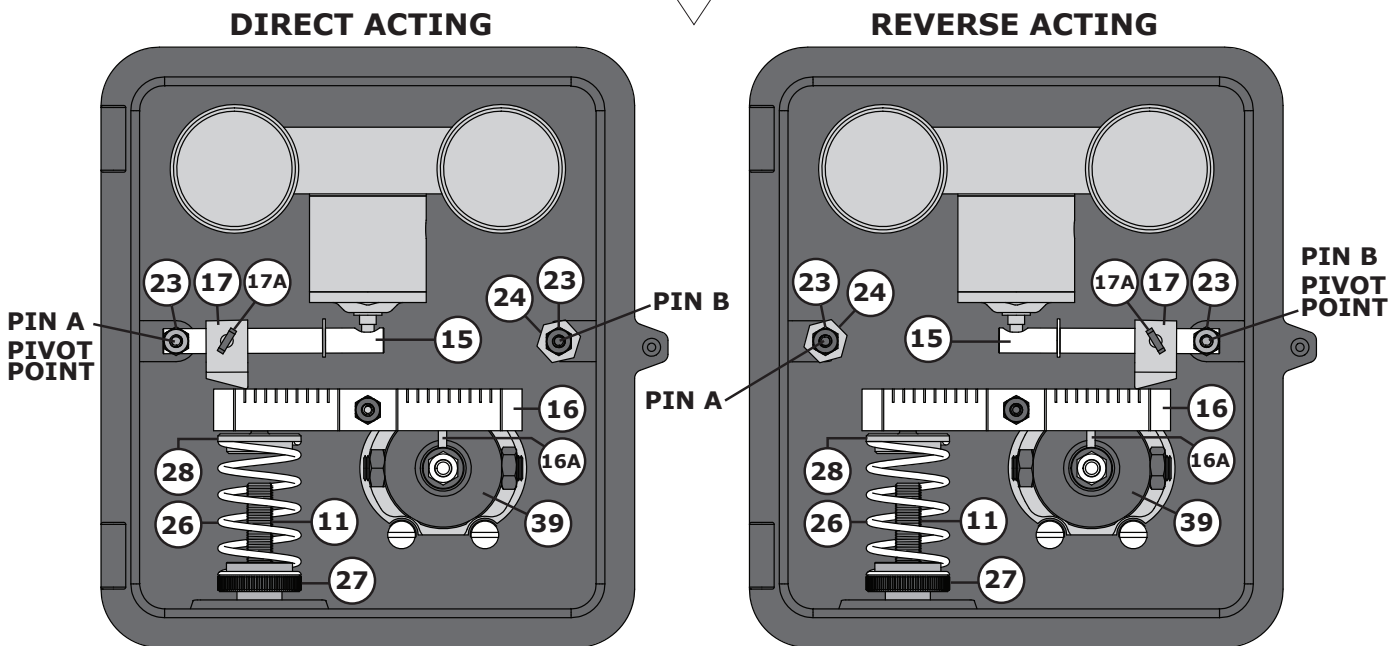

Figure 6 Throttle Pilot

Figure 7 Controller Operation Diagram



GROUND

Model 5000 Level Controller

Operation, Parts, and Instruction Manual



CHANGING CONTROLLER ACTION

NOTE

Changing the Pilot action from Snap Acting to Throttling requires changing the internal components of the Pilot. See Pneumatic Pilot Operations and Maintenance (Page 9 and 11).

5000 Level Controllers are typically shipped from factory set for Direct-Action, the following instructions outline controller conversion from Direct to Reverse-Action.

A controller set for Direct-Action will have the fulcrum block (Key 17) to the right of the pivot point, a Reverse-Acting controller will have the fulcrum block to the left of the pivot point (See Figure 7).

- 1 Locate the retainer removal tool (Key 24, labeled as "TOOL" with a sticker on the right side of the case) and remove the tool from mounting pin 'B' (Key 21) by removing the 3/8" nut (Key 23) holding it in place. Set the retainer removal tool and nut aside.
- 2 It may be necessary to loosen the tension on the spring (Key 26) by lowering the spring adjuster (Key 27) before proceeding to remove the flapper shaft (Key 15).
- 3 Once the tension on the spring has been reduced, remove the 3/8" nut (Key 23) holding the flapper shaft in place. Lower the flapper shaft so that the seat of the flapper shaft is free from the pilot thrust pin (Key 58 for snap acting, Key 60 for throttle) and pull the flapper shaft off of mounting pin 'A' (Key 21).
- 4 Remove the fulcrum block thumb screw (Key 17A) from the fulcrum block (Key 17) and flip the flapper shaft / fulcrum block assembly horizontally to fit on to mounting pin 'B'.
- 5 Thread the 3/8" nut (Key 23) onto mounting pin 'B' and tighten it to hold the flapper shaft in securely in place but loose enough to still allow the flapper shaft to move freely on the mounting pin. Thread the fulcrum block thumb screw into the fulcrum block but do not tighten the thumb screw completely until the controller operation is re-adjusted.
- 6 Slide the retainer removal tool onto mounting pin 'A' and secure it in place using the other 3/8" nut.
- 7 See Controller Liquid Level Operation Adjustment (Page 7).

CONTROLLER MAINTENANCE

WARNING

The following maintenance procedures require taking the controller out of service. To avoid personnel injury, only qualified technicians should perform the following procedures. Always ensure the controller is fully released of pressure or process fluid before starting maintenance. Be cautious of flammable instrument gas that could be present.

- 1 Disconnect the supply and output pressure lines, also disconnect any vent lines if present.
- 2 Contain any process fluid and vent any process pressure from the vessel. Use safety lock-out procedures to be sure that the above provisions remain in effect while you complete the work on your equipment.
- 3 Check for process fluid leakage to the atmosphere through the body to vessel connection.
- 4 Examine the controller for damage caused by corrosive fumes or process drippings.
- 5 Ensure all accessories, mounting brackets and fasteners are secure.
- 6 Clean any dirt and foreign material from moving parts and operating medium supply ports.

Replacing Gauges

(Reference Figures 11 to 18)

- A 2 gauges are used (Key 52), one for output (right side) and one for supply (left side) pressure.
- B Always ensure to check the range of the controller before ordering replacement gauges (0-30 Psi gauges WILL NOT work on a 6-30 Psi controller). See nameplate (Key 6).
- C Always use approved thread sealant on the threaded connections.



Model 5000 Level Controller

Operation, Parts, and Instruction Manual

CONTROLLER MAINTENANCE

(Continued)

Controller / Body Disconnection

NOTE

The 5000 Level Controller may be serviced without disconnecting the body (Key 12) from the vessel if maintenance to the displacer (Key 41) is unnecessary. Use caution when removing the controller, the displacer assembly (Keys 41, 42, 43, 46) is at risk of being pushed inside the vessel. Prevent the displacer arm from being able to be pushed into the vessel once the body is disassembled.

- 1 Relieve the spring tension on the fulcrum block (Key 17) by loosening the spring adjuster (Key 27).
- 2 Remove the 4 machine screws (Key 22) holding the case (Key 13) to the body, you may need to move the fulcrum block assembly out of the way as necessary.
- 3 Pull the controller away from the body being careful that the fulcrum bar pin (Key 16A) is pulled out of the trunnion head groove. Inspect the body gasket (Key 18) and replace if necessary.

Seal Replacement / Body Disassembly

(Reference Figures 11 to 14)

- 1 Set the controller gauges up on a flat working surface. Remove the retainer removal tool (Key 24) from the mounting pin (Key 21) by removing the 3/8" nut (Key 23). Set tool aside for use in body disassembly.
- 2 Remove the 1/4" nut (Key 45) and lock washer (Key 44) from the displacer arm (Key 42). Caution, at this point it is possible to lose the displacer arm and displacer assembly inside the vessel.
- 3 Use a 3/16" hex key to immobilize the bearing screws (Key 33) while using a 9/16" wrench to loosen and remove the jam nuts (Key 34). Using the 3/16" hex key, completely remove the bearing screws and remove the trunnion head (Key 39).
- 4 Inspect the bearings (Key 40) for wear and damage, replace if necessary.

- 5 Slide the retainer removal tool over the protruding end of the displacer arm and into the retainer (Key 37). Using a 1/2" wrench on the retainer removal tool, remove the retainer from the body.
- 6 Using a mechanics pick set, remove the backup ring (Key 32), displacer arm o-ring (Key 35), seal carrier (Key 38), and seal carrier o-ring (Key 36). Be careful not to damage the displacer arm and body bore, replace both o-rings.
- 7 Inspect the body bore and displacer arm for damage.

Re-assembly

(Reference Figures 11 to 18)

NOTE

The following instructions outline controller body assembly for a controller that is already connected to a vessel where the displacer assembly has not been removed from the body (Key 12). Use caution re-assembling components around the displacer arm as the displacer assembly is at risk of being pushed into the vessel.

- 1 Apply o-ring lubricant to the seal carrier o-ring (Key 36) and displacer arm o-ring (Key 35). Slide the seal carrier o-ring over the displacer arm (Key 42) and into the body bore.
- 2 Insert the seal carrier (Key 38) over top of the seal carrier o-ring inside the body, insert the tapered end of the seal carrier first as shown in Figures 13 and 14.
- 3 Slide the displacer arm o-ring over the displacer arm and into the seal carrier. Lubricate the backup ring with o-ring lubricant and install it on top of the displacer arm o-ring.
- 4 Cover the threads of the retainer (Key 37) with liquid thread locker and using the retainer removal tool (Key 24) thread the retainer into the body. Use a 1/2" wrench on the retainer removal tool and torque the retainer to 60 Ft-lb.
- 5 If the bearings (Key 40) were removed, re-install them into the grooves on the outside of the body using a rubber mallet.
- 6 If the body gasket (Key 18) needed to be replaced, glue a new body gasket to the body. Ensure that the 4 holes on the body gasket are in alignment with the 4 screw holes of the body.

Model 5000 Level Controller

Operation, Parts, and Instruction Manual



CONTROLLER MAINTENANCE

(Continued)

Re-assembly

(Continued)

- 7 Place the trunnion (Key 39) over the end of the body and align the holes in the trunnion with the holes in the bearings. Thread the bearing screws (Key 33) through the trunnion and into the bearings. Use a 3/16" hex key to tighten the bearing screws until snug but not tight enough to restrict trunnion movement.
- 8 Thread the jam nuts (Key 34) onto the bearing screws, then immobilize the bearing screws using the hex key to hold the bearing screws and a 9/16" wrench to tighten the jam nuts to the trunnion. It is important that the trunnion is able to move freely over the body once the jam nuts have been tightened.
- 9 Slide the lock washer (Key 44) over the end of the displacer arm, snug to the trunnion. Thread the 1/4" nut (Key 45) over the displacer arm and tighten to 12 Ft-lb.

Pneumatic Pilot Maintenance

(Reference Figures 5, 6, and 16)

Follow the steps at the beginning of Controller Maintenance on Page 11.

Disassembly

- 1 Using a 5/32" hex key remove the two cap screws (Key 63) on the back of the case (Key 13) and remove the pilot manifold from the case.
- 2 Remove and inspect the manifold o-rings (Key 55), replace if necessary.
- 3 Using a 5/16" socket wrench to remove the socket cap screws (Key 65) from the pilot body (Key 56). Remove the cap (Key 49).

Snap (On/Off) Pilot

- A Remove the pilot thrust pin (Key 58) and inspect. Remove the pilot body (Key 56), be careful not to lose the ball bearing (Key 47).

- B Remove the manifold gasket (Key 54) and replace if necessary. Remove the pilot filter (Key 51) and replace if necessary. Remove the ball bearing and inspect for corrosion.

Throttle Pilot

- A Remove the throttle pin valve assembly (Key 59) and inspect the diaphragm for damage.
- B Separate the pilot body (Key 56) from the manifold (Key 57), be careful not to lose the throttle spring in process. Remove the manifold gasket, throttle thrust pin (Key 59), throttle spring (Key 60), and pilot filter.
- C Inspect the manifold gasket, throttle spring, and filter. Replace as necessary.

Re-assembly

Snap (On/Off) Pilot

- A With the manifold (Key 57) upside down, insert the pilot filter (Key 51) and ball bearing (Key 47) into the manifold. Place the manifold gasket (Key 54) over the opening for the filter and align the three gasket holes with those of the manifold.
- B Place the pilot body (Key 56) on top of the gasket, make sure to align the three holes in the pilot body with those of the manifold gasket. Slide the thrust pin (Key 59) into the pilot body and place the cap (Key 49) over the thrust pin so that the end of the thrust pin protrudes from the opening in the cap.
- C Thread the two socket cap screws (Key 65) into the pilot body (Key 56) and using a 5/16" socket wrench tighten them completely through the pilot body and into the manifold.

Throttle Pilot

All replacement throttle pilot internals are all included in one replacement kit, if the diaphragm needs to be replaced the replacement parts kit includes a pre-assembled throttle pin valve assembly. Disassembly and re-assembly of the throttle pin valve assembly is unnecessary.

- A Insert the pilot filter (Key 51) into the manifold (Key 57). Place the manifold gasket (Key 54) over the filter opening in the manifold, align the three holes on the gasket with those of the manifold.



Model 5000 Level Controller

Operation, Parts, and Instruction Manual

CONTROLLER MAINTENANCE

(Continued)

Pneumatic Pilot Maintenance

(Continued)

Re-assembly (Continued)

Throttle Pilot (Continued)

- B** Install the narrow end of the throttle spring (Key 60) into the spring groove on the seat of the throttle thrust pin (Key 59). Place the wide end of the spring / pin assembly inside of the pilot filter.
- C** Slide the pilot body over the thrust pin and onto the manifold gasket, be careful to align the three holes in the pilot body with those of the manifold and gasket.
- D** Lay the throttle pin valve assembly (Key 59) over the pilot body so that the seat of the valve assembly is lined up with the seating surface of the thrust pin. Be sure the holes of the diaphragm and pilot body are aligned.
- E** Place the cap (Key 49) over the gasket and exhaust of the throttle pin valve assembly, line up the holes in the cap with those in the gasket and pilot body. Thread the 2 socket cap screws through the cap, pilot body, and into the manifold. Completely tighten the socket cap screws using a 5/16" socket wrench.

Pneumatic Pilot Manifold Installation

(Reference Figure 16)

- 1** Slide the manifold o-rings (Key 55) in place over the Input and Output ports on the back of the manifold (Key 57).
- 2** Place the manifold inside the case (Key 13) and position it so that the Input and Output ports are sticking through the back of the case.
- 3** Thread the socket cap screws (Key 63) through the holes on the back of the case and into the pilot manifold. Using 5/32" hex key, tighten the socket cap screws.

Electric Pilot Maintenance

(Reference Figure 18 & 19)

NOTE

If you suspect that your 5000E Electric Pilot is malfunctioning, it is recommended that a certified electrician check for a loss of signal between electrical connections inside the pilot using an ohm meter.

Refer to the initial steps of Controller Maintenance before proceeding (Page 11).

Disassembly / Pilot Removal

- 1** Have a certified electrician disconnect all wiring to the controller and inside the pilot (Key 50). Use the hex key provided (located in the bottom of the controller case, Key 19) loosen the 4 socket cap screws (Key 50A) and remove the front panel of the electric pilot.
- 2** Disconnect the 1/2" nipple (Key 67) from the pilot. If possible, replace the fitting gasket (Key 53) if necessary.
- 3** Using a 5/32" hex key remove the two cap screws (Key 64) on the back of the case (Key 13) and remove the pilot manifold from the case.
- 4** Remove and inspect the manifold o-rings (Key 55), replace if necessary.
- 5** Using a 1/4" hex key remove the socket cap screws holding the base adapter (Key 48) to the pilot. Once the base adapter is removed, replace the pilot.

Electric Pilot Installation

WARNING

Always have a certified electrician perform any electrical work on the 5000E Level Controller.

- 1** Mount the base adapter (Key 48) to the electric pilot (Key 50) using the socket cap screws (Key 65) and a 1/4" hex key.
- 2** Install the manifold o-rings (Key 55) into the grooves on the base adapter. Place the pilot manifold in the case (Key 13), thread the socket cap screws (Key 64) through the back of the case and into the base adapter. Tighten the socket cap screws using a 5/32" hex key.
- 3** Using good piping practices, wrap the threads of the 1/2" nipple (Key 66) with PTFE tape and thread the nipple through the case and into the electric pilot.
- 4** Install the fitting gasket (Key 53) over the nipple and snug to the case.
- 5** Feed the wiring for the pilot into the case. Refer to Controller Liquid Level Operation Adjustment, Electric Pilot Controller (Page 7) for electric pilot set-up.

Model 5000 Level Controller

Operation, Parts, and Instruction Manual

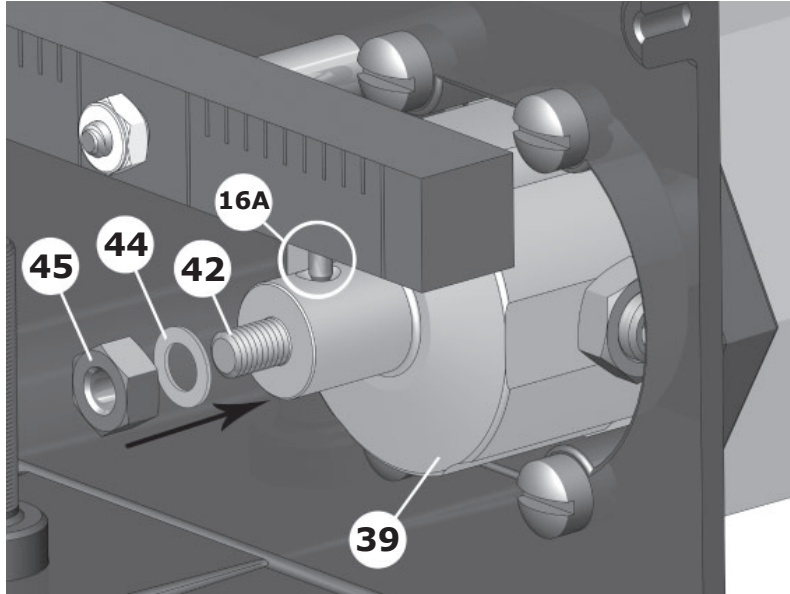

Figure 8
Displacer Arm Assembly

Figure 9
Vertical Displacer Assembly

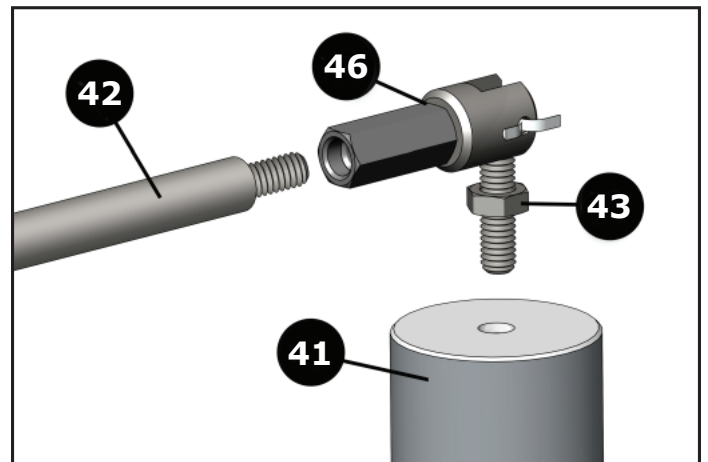
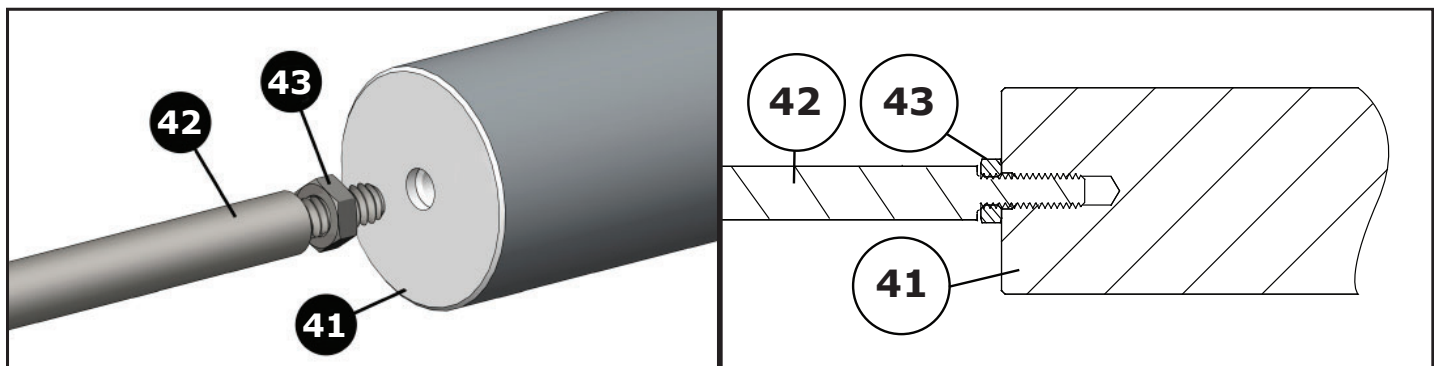

Figure 10 *Horizontal Displacer Assembly*





Model 5000 Level Controller

Operation, Parts, and Instruction Manual

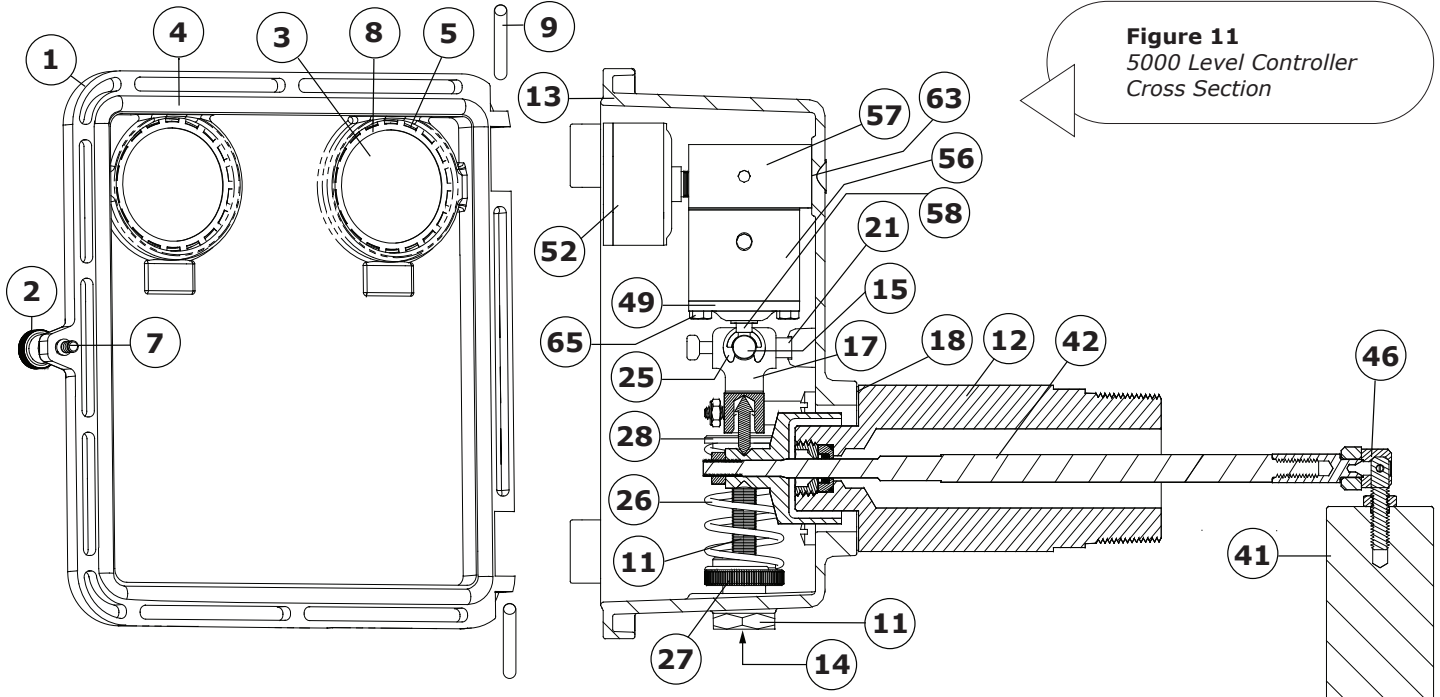
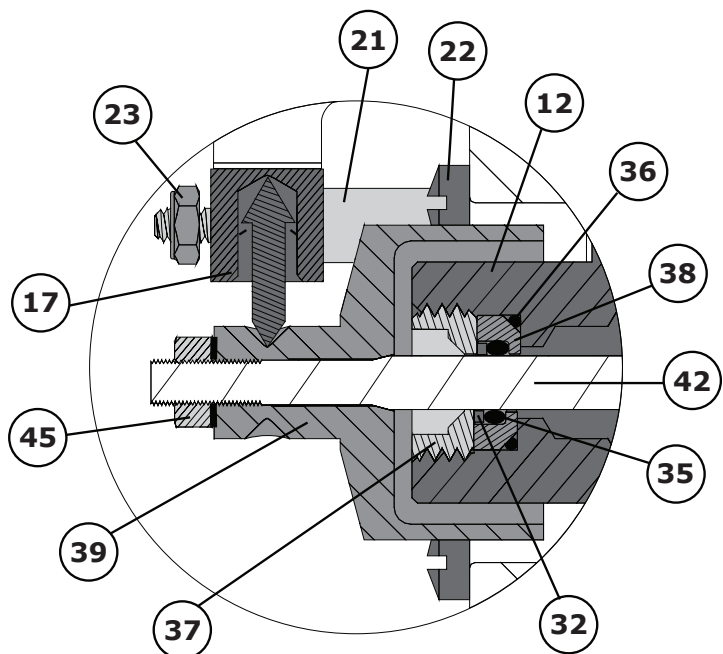
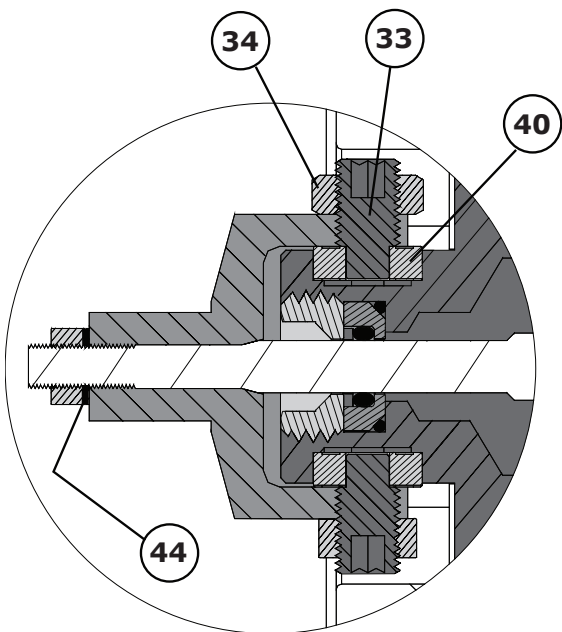

Figure 11
5000 Level Controller
Cross Section

Figure 12 Trunnion Cross Section Top View

Figure 13 Trunnion Cross Section Side View



Model 5000 Level Controller

Operation, Parts, and Instruction Manual

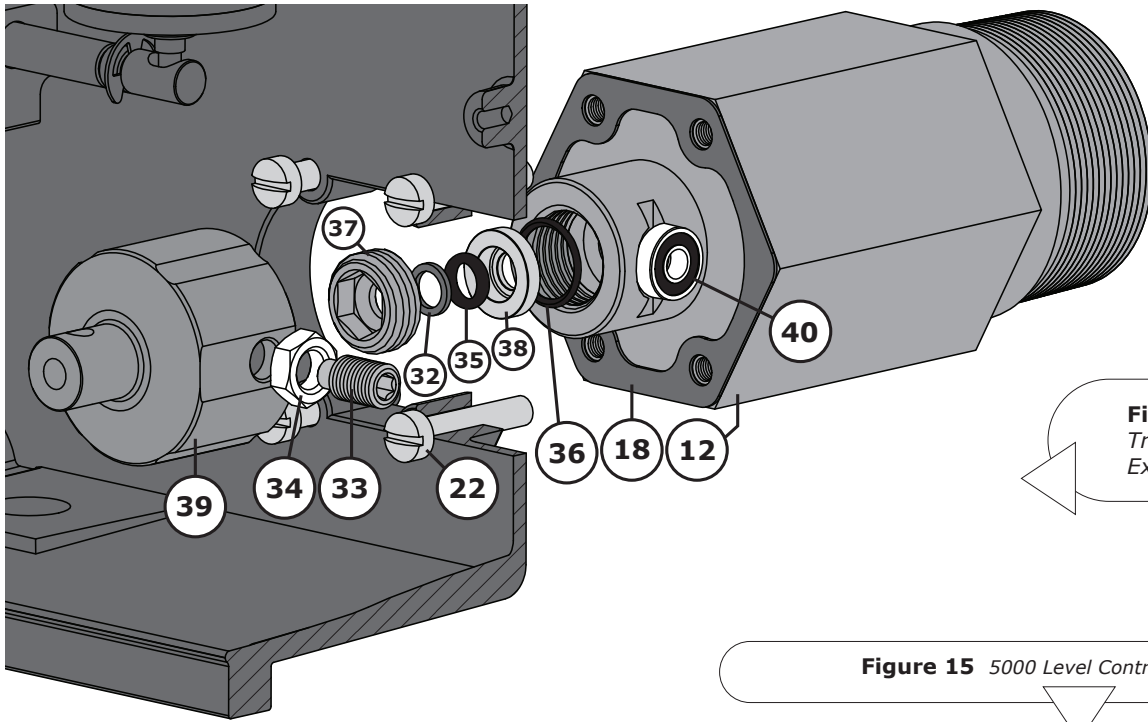
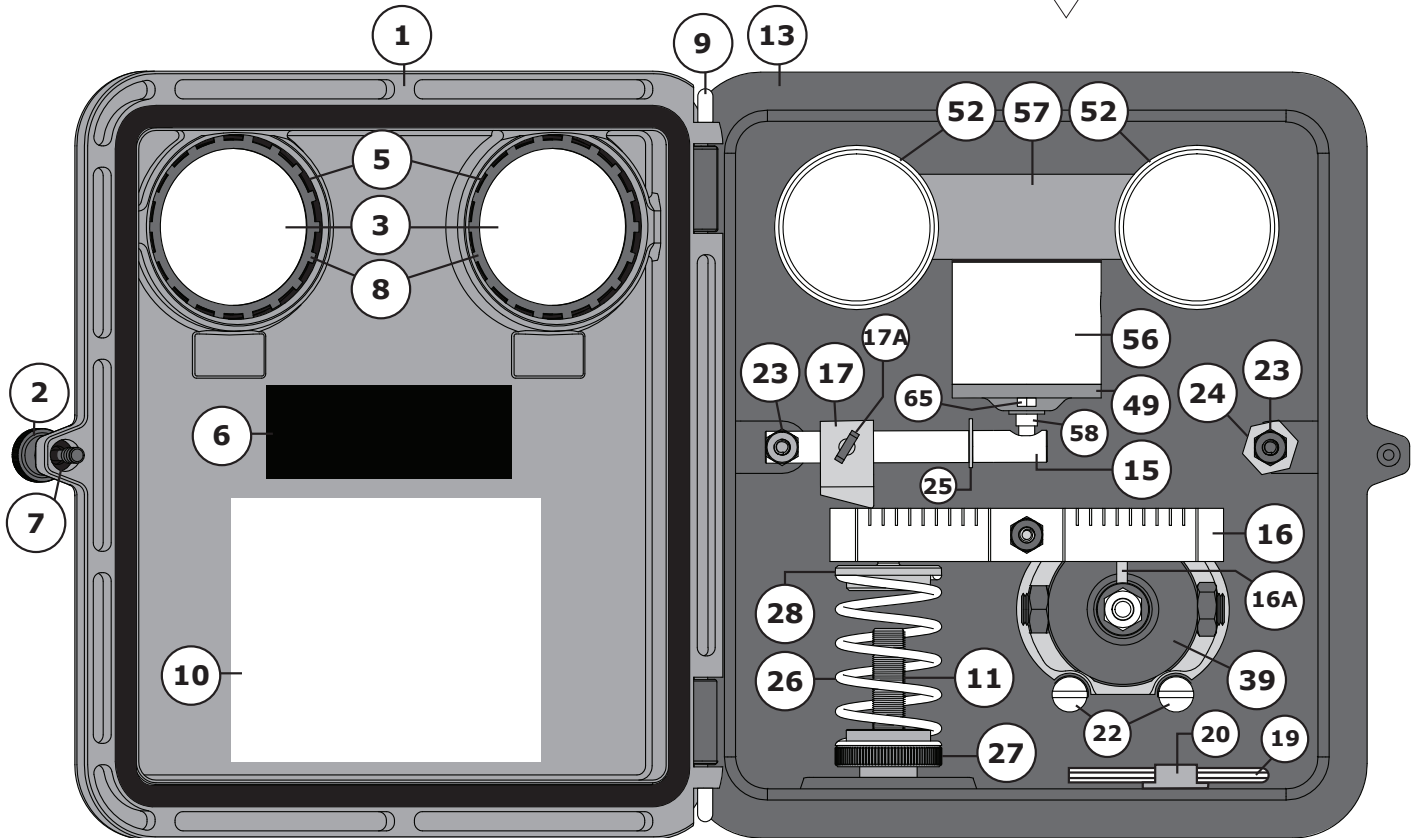

Figure 14
Trunion Assembly
Exploded View

Figure 15 5000 Level Controller Front View





Model 5000 Level Controller

Operation, Parts, and Instruction Manual

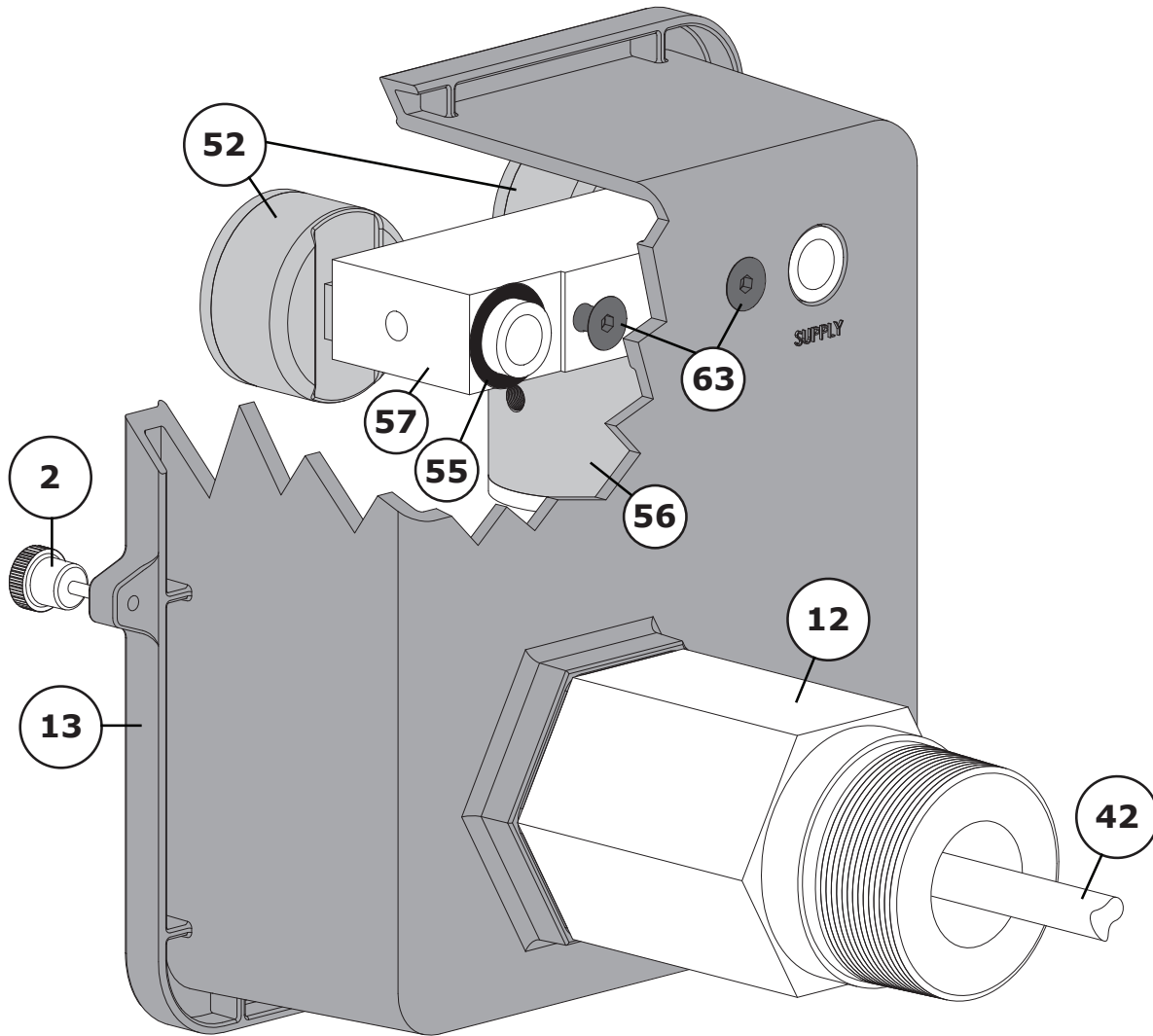

Figure 16 5000 Level Controller Back View

Model 5000 Level Controller

Operation, Parts, and Instruction Manual

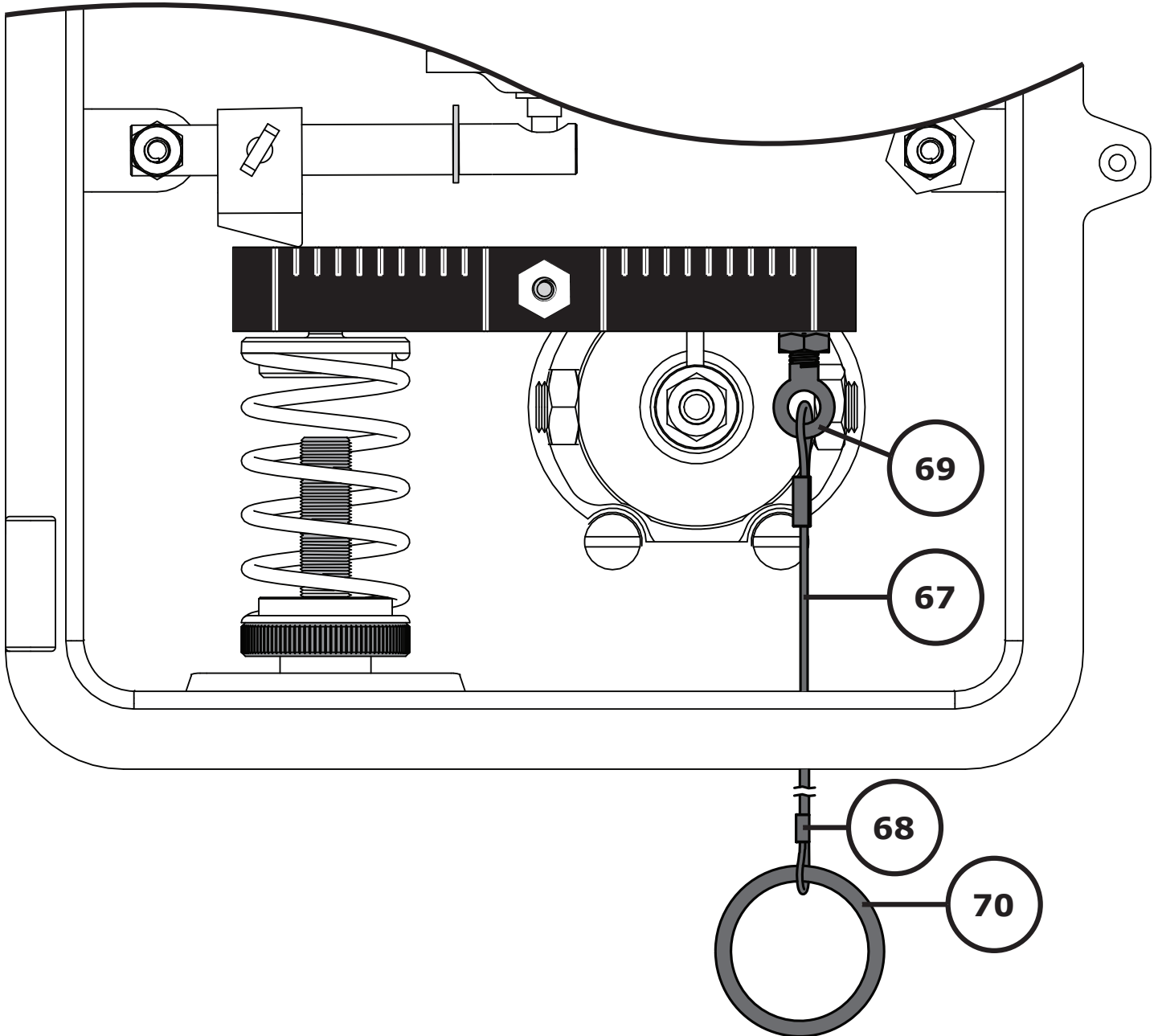

Figure 17 Manual Test Apparatus Diagram



Model 5000 Level Controller

Operation, Parts, and Instruction Manual

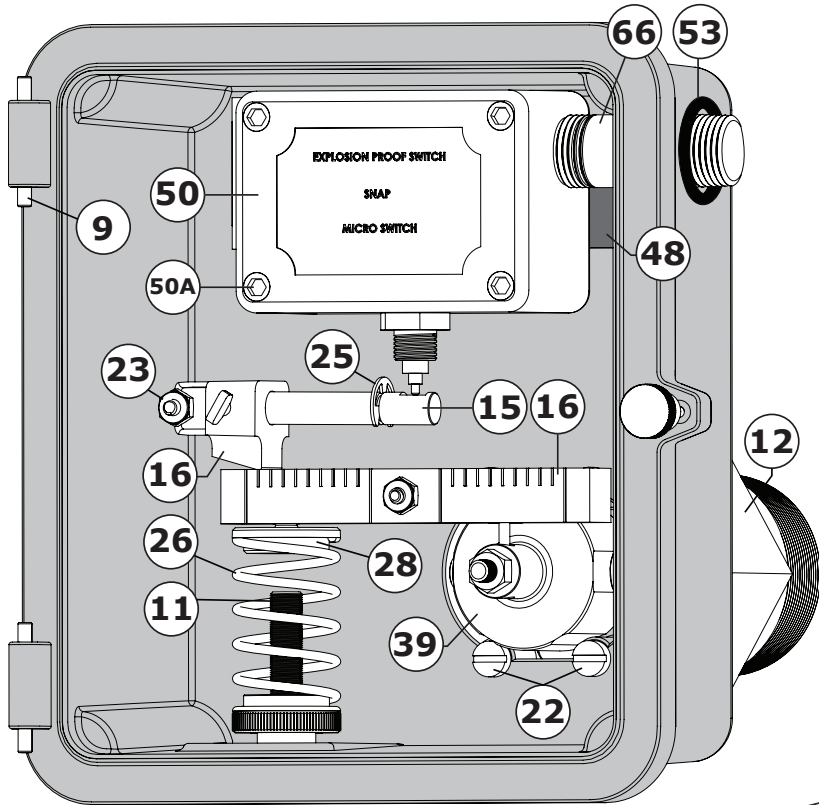

Figure 18
5000E Level Controller
Front View

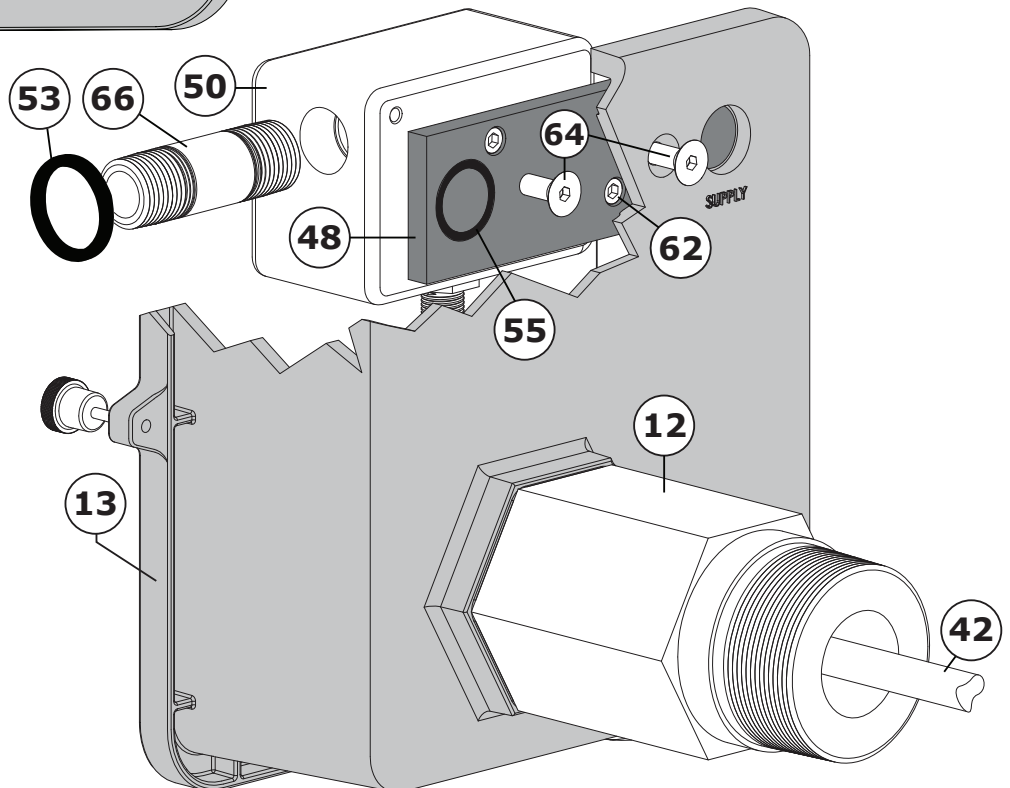

Figure 19
5000E Level Controller
Back View

Model 5000 Level Controller

Operation, Parts, and Instruction Manual



Parts

Case Cover (Refer to Figure 6)

Key	Description	Part Number
1	Case Cover, Aluminum	DF5000X003D
2	Case Cover Screw, SST/Plastic	18A1080X01D
3	Gauge Glass, Lexan, Qty: 2	DF5000X044D
4	Gasket, Case Cover, Neoprene	DF5000X014D
5	Gasket, Gauge Glass, Neoprene, Qty: 2	0T01910408D
6	Nameplate, SST	NAME135000D
7	O-ring, Case Cover Screw, Nitrile	DF5000X039D
8	Retaining Ring, Gauge Glass, SST, Qty: 2	PC00000006D
9	Roll Pin, Cover Hinge, SST, Qty: 2	1H28882899D
10	Cover Sticker, Vinyl	DF5000X038D

Case (Refer to Figure 11 & 15)

Key	Description	Part Number
11	Adjusting Thread, Aluminum	DF5000X017D
12	Body, WCC	
	1.5" MNPT	DF5000X501D
	2" MNPT	DF5000X001D
if you need a flanged body as a replacement part, contact Dyna-Flo for more information.		
13	Case, Aluminum	
	5000	DF5000X002D
	5000E	DF5000EX02D
14	Screen Vent, Plastic/Metal	Y602-12CRN
15	Flapper Shaft, S30300	
	5000	DF5000X008D
	5000E	DF5000EX08D
16	Fulcrum Bar Assembly, Aluminum	DF5000X710D
16A	Fulcrum Bar Pin, S31600	
17	Fulcrum Block Assembly, 18-8 & Nylon	DF5000X015D
17A	Thumb Screw, 18-8	
18	Gasket, Body, Neoprene	DF5000X013D
19	Hex Key, Steel	PC0000X129D
20	Hex Key Tool Holder	PC0000X137D
21	Mounting Pin, S30300	
	Flapper Shaft, Qty: 2	DF5000X010D
	Fulcrum Bar, Qty: 1	DF5000X009D

Case (Continued)

Key	Description	Part Number
22	Machine Screw, Zinc Plated Steel	MLPSC14.100
23	Nut, Mounting Pin, SST, Qty: 3	LHC18.8.1024
24	Retainer Removal Tool, SST	DF5000X040D
25	Retainer Ring, Flapper Shaft, Steel (Zinc Plated)	DF5000X034D
26	Spring, S30200	DF5000X0C7D
27	Spring Adjuster, Aluminum	DF5000X005D
28	Spring Seat, Aluminum	DF5000X006D
29	Sticker, Pin Warning, Vinyl	DF5000X060D
30	Sticker, Tool, Vinyl	DF5000X043D
31	Tag, Pin Warning, Paper	DF5000X052D

Trunnion Assembly (Refer to Figures 12 - 14)

Key	Description	Part Number
32	Backup Ring, Carbon Teflon	DF5000X035D
33	Bearing Screw, S30300, Qty: 2	DF5000X019D
34	Jam Nut, Bearing Screw, S18800, Qty: 2	RHJ18.8F38
35	O-ring, Displacer Arm	
	HSN	DF5000X032D
	Viton	DF5000X050D
36	O-ring, Seal Carrier	
	HSN	DF5000X033D
	Viton	11A8741X01D
37	Retainer, S30300	DF5000X029D
38	Seal Carrier, S31600	DF5000X028D
39	Trunnion, Aluminum	DF5000X012D
40	Trunnion Bearings, S44004	DF5000X016D

Displacer Assembly

(Refer to Figure 10 & 11)

Key	Description	Part Number
41	Displacer	
	PVC	
	4"	DF5000X426D
	6"	DF5000X626D
	9"	DF5000X926D
	12" (Standard)	DF5000X026D
	SST	
	12"	DF5000X316D



Model 5000 Level Controller

Operation, Parts, and Instruction Manual

Parts (Continued)

Displacer Assembly

(Continued) (Refer to Figure 10 & 11)

Key	Description	Part Number
42	Displacer Arm, S31600	
	11"	DF5000X111D
	14"	DF5000X114D
	17" (Standard)	DF5000X011D
	20"	DF5000X120D
	24"	DF5000X124D
43	Jam Nut, Displacer, SST	NHJ18.8C516
44	Lock Washer, Zinc Plated	LWEZ14
45	Nut, Displacer Arm, Zinc Plated	NH8FZ14
46	Swivel Assembly, SST	DF5000X027D

Pilot Assembly

(Refer to Figure 10 & 11)

Key	Description	Part Number
47	Ball Bearing, S30200	DF5000X036D
48	Base Adapter, Electric Pilot, Aluminum	DF5000EX25D
49	Cap, Aluminum	DF5000X021D
50	Explosion Proof Switch (Electric Pilot)	
	SPDT (Single Pole Double Throw)	DF5000EXSPD
	DPDT (Double Pole Double Throw)	DF5000EXDPD
50A	Socket Cap Screw	Part of Key 52
51	Filter, SST Mesh	DF5000X022D
52	Gauge, Qty: 2	
	Brass	
	0 - 30 Psi	G2B8030BD0D
	0 - 60 Psi	G2B8060BD0D
	SST	
	0 - 30 Psi	G2S8030BD0D
	0 - 60 Psi	G2S8060BD0D
53	Gasket, Elbow Fitting, Nitrile	DF5000EX22D
54	Gasket, Pilot Manifold, Neoprene	Part of Repair Kit DF5000X037D
55	O-ring, Pilot Manifold, Nitrile, Qty: 2	1C78120699D
56	Pilot Body, Aluminum	DF5000X020D
57	Pilot Manifold, Aluminum	DF5000X025D

Pilot Assembly (Continued)

Key	Description	Part Number
58	Pilot Thrust Pin, S31600/S31603 Dual Grade	
	Snap	DF5000X024D
	Throttle	Part of Repair Kit DF5000X037D
59	Throttle Pin Valve Assembly	
60	Throttle Spring, SST,	Part of Repair Kit DF5000X037D
61	Retaining Ring, Zinc Plated Steel,	DF5000X031D
62	Socket Cap Screw, Base Adapter, 18-8, Qty: 2	DF5000EX52D
63	Socket Cap Screw, Case, 18-8, Qty: 2	PC00000051D
64	Socket Cap Screw, Case (Electric Pilot), 18-8, Qty: 2	DF5000EX52D
65	Socket Cap Screw, Pilot Assembly, 18-8, Qty: 2	H18.8F1032.200
66	1/2" Nipple, 18-8	PFN12125X4D

Manual Test Apparatus

(Refer to Figure 17)

DF5000EX10D

Key	Description
67	Cable, SST
68	Cable Ferrule, Aluminum, Qty:2
69	Eye Bolt, Steel (Zinc Plated)
70	Ring, Steel (Zinc Plated)

Model 5000 Level Controller

Operation, Parts, and Instruction Manual



Repair Kits

Part Numbers

Soft Parts Repair Kit (for HNBR seal material)**RDF5000X01D**

Kit Contains Keys: 4, 5, 7, 18, 32, 35, 36, 53, 54, 55

Throttle Pilot Repair Kit (for HNBR seal material)**DF5000X037D**

Kit Contains Keys: 51, 54, 58, 59, 60

Snap Pilot Repair Kit (for HNBR seal material)**DF5000X047D**

Kit Contains Keys: 47, 51, 54, 58

Parts Ordering

Whenever corresponding with Dyna-Flo about a 5000 Level Controller, refer to the nameplate (Key 6, Figure 15) for the serial number of the unit. Please order by the complete part number (as given in the following parts list) of each part required.

Our Commitment to Quality

Dyna-Flo is committed to continuous improvement. While all efforts have been made to ensure the accuracy of the content in this document, modifications or improvements to the information, specifications, and designs may occur at any time without notice. This document was published for informational purposes only, and does not express or imply suitability, a warranty, or guarantee regarding the products or services described herein or their use or applicability.

Neither Dyna-Flo Control Valve Services Ltd., nor any of their affiliated entities assumes responsibility for the selection, use and maintenance of any product. Responsibility for selection, use and maintenance of any product remains with the purchaser and end-user.



Model 5000 Level Controller

MODEL NUMBERING SYSTEM

SAMPLE PART NUMBER: 5000-20MS-0S-B3B-VDP

MODEL						-	
-	PNEUMATIC		E	ELECTRIC		-	
END CONNECTION SIZE						20	
15	1.5 INCH	20	2 INCH	30	3 INCH	40	4 INCH
END CONNECTION TYPE						M	
F	RAISED FACE (RF) FLANGE		J	RING TYPE JOINT (RTJ) FLANGE		M	
M	SCREWED MNPT		S	SPECIAL			
SPRING CHOICE						S	
L	LIGHT (GREEN)		M	MEDIUM (WHITE)		S	
S	HEAVY (YELLOW)		E	EXTRA HEAVY (RED)			
PRESSURE RATING						0	
0	MNPT (3,750 PSIG / 25,855 KPAG)		1	ASME 150 (285 PSIG / 1,965 KPAG)		0	
3	ASME 300 (740 PSIG / 5,102 KPAG)		6	ASME 600 (1,480 PSIG / 10,204 KPAG)			
9	ASME 900 (2,220 PSIG / 15,306 KPAG)		5	ASME 1500 (3,750 PSIG / 25,855 KPAG)			
PILOT						S	
D	DPDT (ELECTRIC PILOT)		P	SPDT (ELECTRIC PILOT)		S	
S	SNAP (PNEUMATIC ON/OFF PILOT)		T	THROTTLE (PNEUMATIC MODULATING PILOT)			
SPECIAL CONSTRUCTION							
-	NONE		T	MANUAL TEST APPARATUS (5000E ONLY)			
SEAL MATERIAL / BACKUP RING						B	
B	HSN (HIGHLY SATURATED NITRILE)(NACE) / CPTFE		V	VITON / CPTFE		B	
X	SPECIAL						
GAUGE TYPE						3B	
3B	0-30 PSI (0-207 KPA) BRASS INTERNALS		3S	0-30 PSI (0-207 KPA) SST INTERNALS		3B	
6B	0-60 PSI (0-414 KPA) BRASS INTERNALS		6S	0-60 PSI (0-414 KPA) SST INTERNALS			
00	MODEL 5000E						
DISPLACER ARM						-	
-	STANDARD (17 INCH)	C	11 INCH	D	14 INCH	E	20 INCH
F	24 INCH						
DISPLACER TYPE						V	
V	VERTICAL		H	HORIZONTAL		V	
DISPLACER SIZE						D	
B	6 INCH		C	9 INCH		D	
D	12 INCH (STANDARD)		E	6 INCH + 12 INCH			
F	4 INCH + 4 INCH + 4 INCH (2 CHAIN LINKS)		X	SPECIAL			
DISPLACER MATERIAL						P	
P	PVC		S	STAINLESS STEEL		P	

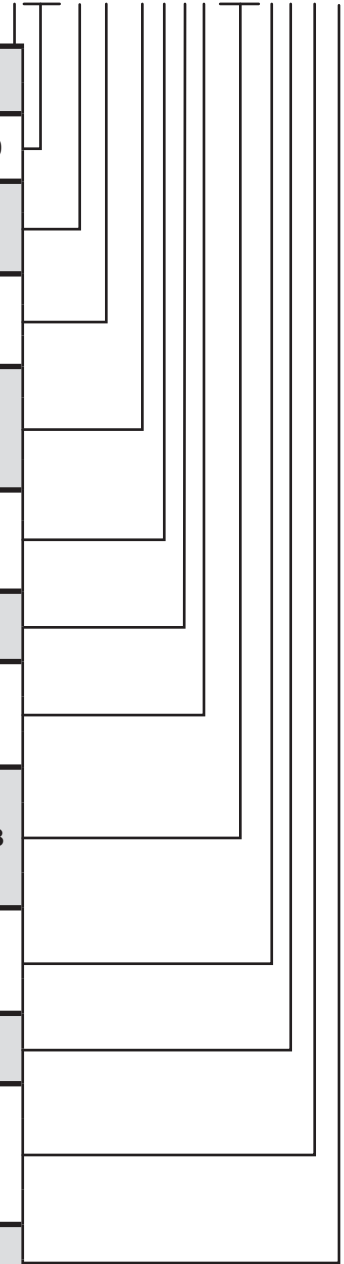

5000

-